



November 6, 2013
REPORT #E13-267

Laboratory Assessment of Sanden GES-15QTA Heat Pump Water Heater

Prepared by:
Ecotope, Inc.
Ben Larson and Michael Logsdon
4056 9th Ave NE
Seattle, WA, 98105

Northwest Energy Efficiency Alliance
PHONE
503-688-5400
FAX
503-688-5447
EMAIL
info@neea.org

Table of Contents

Executive Summary	i
1. Introduction.....	1
2. Methodology.....	3
3. Findings: Equipment Characteristics.....	8
3.1. Basic Equipment Characteristics.....	8
3.2. Operating Modes and Sequence of Heating Firing	11
4. Findings: Testing Results	12
4.1. First Hour Rating and Energy Factor	12
4.1.1. 1-hour Test.....	12
4.1.2. Energy Factor Tests	13
4.2. Efficient Showers Test.....	17
4.3. Low Temperature Limit.....	18
4.4. Compressor Output Capacity and Efficiency	18
4.5. Noise Measurements and Additional Observations	20
5. Conclusions.....	22
References	23
Appendix A: Testing Matrices.....	25
Appendix B: Measurement Instrumentation List.....	26

List of Figures

Figure 1. HPWH Test Unit Installed Inside Thermal Chamber4
 Figure 2. General Test Setup4
 Figure 3. Custom Lid for Thermocouple Tree Access.....5
 Figure 4. Thermocouple Temperature Tree.....5
 Figure 5. Power Measurement and Data Acquisition Schematic6
 Figure 6. Fan Test Setup and Duct Connections10
 Figure 7. Fan Characteristics10
 Figure 8. Tank Thermistor Heights.....11
 Figure 9. DOE 1-Hour Test13
 Figure 10. DOE 24-Hour Simulated Use Test, First Six Hours15
 Figure 11. DOE 24-hour Simulated Use Test, Full 24 Hours15
 Figure 12. DOE 24-hour, 50° F Ambient Air 50° F Inlet Water, First Six Hours.....16
 Figure 13. DOE 24-hour, 50° F Ambient Air 50° F Inlet Water, Full 24 Hours.....16
 Figure 14. Shower Test Supplemental Draw Profile17
 Figure 15. COP Test at 50° F19
 Figure 16. COP and Heating Output Capacity: 30° F, 50° F, and 67° F20

List of Tables

Table 1. Basic Characteristics for Sanden GES.....9
 Table 2. Performance Characteristics for Sanden GES HB5012
 Table 3. COP and Capacity Measurements20
 Table 4. Sound Level Measurements for Sanden GES21

Executive Summary

The Northwest Energy Efficiency Alliance (NEEA) contracted with Ecotope, Inc. and Cascade Engineering Services, Inc. to conduct a laboratory assessment of the Sanden model # GES-15QTA heat pump water heater (HPWH) for northern climate installations. Cascade Engineering evaluated the GES using a testing plan developed by Ecotope to assess heat pump water heater performance.

The goal of the work: to evaluate the product using the Northern Climate Heat Pump Water Heater Specification (NEEA 2012). The testing plan included observing heat pump efficiency at lower ambient temperatures (30° F, 50° F, and 67° F); conducting the standard 24-hour and 1-hour rating tests; measuring noise output levels; quantifying the number of efficient showers delivered at 50° F ambient; and measuring airflow across the evaporator coil under different ducting regimes. Overall, the results suggest the GES is an extremely efficient heat pump water heater and suitable for nearly all applications in the Pacific Northwest. Specific findings include:

- Measured Northern Climate Specification Metrics:
 - Northern Climate Energy Factor: 2.98
 - Percent of tank drained before resistance elements engage in 1-hour test: 100+%
 - Note: this tank has no resistance elements
 - Number of consecutive, sixteen-gallon, efficient showers: four
 - Sound level: 44 dBA
- The inverter-driven, variable-speed compressor and fan are efficient and maintain heating output capacity as the ambient temperature decreases. Measured coefficients of performance (COPs) range from 2.4 at 30° F to 3.7 at 67° F. As the source air temperature drops, the compressor speeds up. The equipment efficiency decreases, but the capacity is held constant near 5.3 kW.
- The HPWH uses carbon dioxide (CO₂) refrigerant, also known as R-744. R-744 has a broad range of operating temperatures, making it well-suited for use as the energy exchange medium between cold air temperatures and hot tank water temperatures. Tests showed the equipment had no difficulty heating the water to 149° F with a source air temperature of 30° F. In addition, the manufacturer reports operation to at least 5° F.
- Both the supply and exhaust air may be ducted, offering numerous installation possibilities. Given the wide temperature operating range, the supply air can even be drawn from outside for installations in the more temperate Pacific Northwest climates. With the broad temperature operating range and ducting possibilities, the HPWH is well-suited for all climates across the Northwest.
- This HPWH has no resistance element or backup heating system. It is designed to always heat with the compressor. This strategy offers significant efficiency advantages because no chance exists for a complicated draw pattern or control strategy to trigger resistance heat, as can happen with hybrid HPWHs. At the same time, the absence of a backup

heating method is of potential concern in the event of compressor failure or of seriously cold source air temperatures, which may prevent the refrigeration cycle from operating.

- The unit supplied by Sanden is designed for the European market with some market-specific design considerations. The stainless steel tank is relatively small, at forty gallons. The water heater also has a fixed temperature setpoint of 149° F (65° C). These features led the lab to adapt some of the standard testing procedures. Further, a tank targeted for the United States market would likely have a somewhat different configuration.

1. Introduction

The Northwest Energy Efficiency Alliance (NEEA) contracted with Ecotope, Inc. and Cascade Engineering Services, Inc. to conduct a laboratory assessment of the Sanden model # GES-15QTA heat pump water heater (HPWH) for northern climate installations. Cascade Engineering Services of Redmond, WA evaluated the GES using a testing plan developed by Ecotope to assess heat pump water heater performance. The test plan follows that of the Northern Climate Heat Pump Water Heater Specification with several added investigations (NEEA 2012). It consists of a series of tests to assess equipment performance under a wide range of operating conditions with a specific focus on low ambient air temperatures.

The tests included measurements of basic characteristics and performance, including first hour rating and Department of Energy (DOE) Energy Factor (EF); determining heat pump efficiency at lower ambient temperatures (30° F, 50° F, and 67° F); conducting a number-of-showers test at 50° F ambient; and measuring airflow across the evaporator coil under different ducting regimes. Appendix A includes a table describing all tests performed for this report.

The water heater tested is currently designed for and sold in the European market – specifically in France. Unlike previously-tested equipment designed for the United States market, with a fixed, physical relationship between the heat pump and the water tank, the GES water heater consists of two modules (Larson June 2013, Larson March 2013, Larson and Logsdon September 2012, Larson and Logsdon February 2012, Larson and Logsdon February 22, 2012). One module is for the water tank while the other contains the heat pump and heat exchanger. The modules may be stacked vertically or arranged side-by-side.

Figure 1 in the next section shows an example of the side-by-side configuration. In the figure, the heat pump mechanical system is in the module at the left and the water tank is at the right. The figure also highlights the air flow ducting possibilities for the equipment. It has duct fittings for both the inlet and outlet air. In the lab testing, Cascade Engineering installed two elbows facing away from one another to avoid recirculating colder air from the exhaust directly to the inlet.

Sanden supplied the tank unit (model # GEU-15QTA) and heat pump unit (model #GEU-45HPA) for testing. The electrical connections on the unit required 230V, 16A, and 50Hz. To accommodate the different frequency of the European electrical grid, Cascade Engineering used a generator to specifically supply the desired electrical requirements.

This water heater is directed specifically at the European market, which results in different design decisions than those for the United States market. For example, the tank has a storage volume of forty gallons, does not have electric resistance elements, and has a fixed temperature setpoint at 149° F. Ecotope evaluated the unit as-is; however, any equipment destined for the United States would likely have a slightly different configuration of tank size, controls, and setpoint possibilities.

Notably, the GES heat pump uses CO₂ as the refrigerant. Sanden shipped the equipment from overseas, and it consequently required charging with refrigerant at the lab. CO₂ is not a common

refrigerant in local Northwest heating, air conditioning and refrigeration systems, so the lab consulted with Sanden to procure CO₂ of the required purity. Next, Cascade Engineering and Ecotope arranged for Charles Yao, an engineer at Sanden, and Mark Jerome, an experienced HVAC technician of Fluid Market Strategies, to conduct the charging. Ecotope observed the process and noted that it did not differ from charging any other refrigerant. The pressures of the CO₂ canister were also on par with other refrigerants.

2. Methodology

Cascade Engineering collaborated with Ecotope and NEEA to devise methods and protocols suitable for carrying out the testing plan. Cascade Engineering incorporated the following documents into its procedures:

- The heat pump water heater measurement and verification protocol developed by Ecotope for use in a Bonneville Power Administration project (Ecotope 2010)
- Northern Climate Specification for Heat Pump Water Heaters (Northwest Energy Efficiency Alliance 2012)
- Department of Energy (DOE) testing standards (DOE 1998) from Appendix E to Subpart B of 10 CFR 430
- American Society of Heating, Refrigeration, and Air Conditioning Engineers (ASHRAE) Standard 118.2-2006 (ASHRAE Std 118.2)

This section provides the general approach and methodological overview for this test. All figures and schematics in this section are courtesy of Cascade Engineering.

In alignment with the type of test conducted, Cascade Engineering carried out the testing at three different locations within its facility:

- Inside an ESPEC Model # EWSX499-30CA walk-in thermal chamber;
- In a large lab space not thermally controlled, but kept at room-temperature conditions; and
- In a room with low ambient noise.

Because the DOE, draw profile type, and coefficient of performance (COP) tests require tight controls on the ambient air conditions, Cascade Engineering conducted all of those tests in the thermal chamber. The chamber is capable of regulating both temperature and humidity over a wide range, and independently monitors and records temperature and humidity conditions at one-minute intervals. Figure 1 shows the HPWH installed inside the thermal chamber. The test plan did not require tightly-controlled conditions to conduct any one-time measurements of system component power levels or airflows, so Cascade Engineering conducted those tests in the large lab space at the conditions encountered at the time (typically between 55° F and 70° F). Lastly, Cascade Engineering moved the HPWH to a room with ambient noise levels below 35 dBA to measure the noise emanating from the operating equipment.

Figure 1. HPWH Test Unit Installed Inside Thermal Chamber



Figure 2 shows a schematic of the general test setup. Cascade Engineering installed an instrumentation package to measure the required points specified by the DOE test standard, as well as additional points to gain further insight into HPWH operation.

Figure 2. General Test Setup

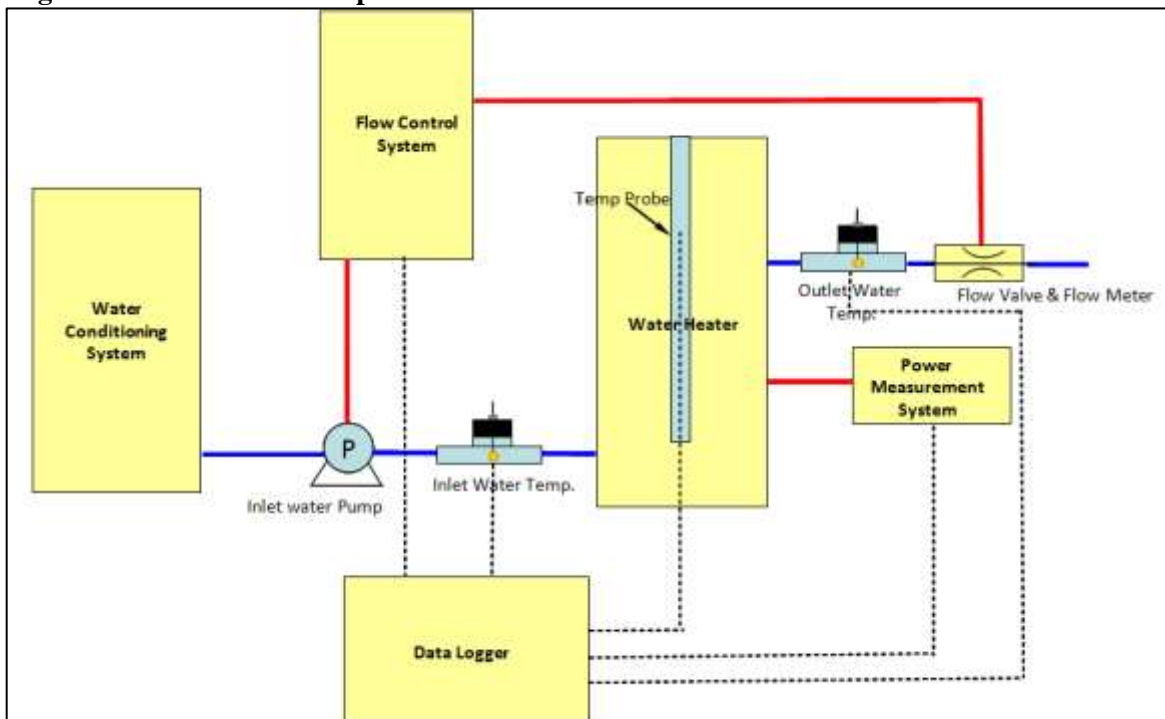

The series of six thermocouples positioned at equal water volume segments measuring tank water temperature warrants special mention. Most electric water heaters have an anode rod port at the top of the tank, which offers convenient access for inserting a straight thermocouple tree near the central axis. Because the GEU tank is all stainless steel and contains no resistance heating elements, no need exists for an anode rod. Without the convenient anode port, Cascade Engineering machined an alternate lid for the tank, which contained a special access port. Figure 3 shows the custom lid sitting on top of the tank next to the standard lid. The lid is installed between the water inlet and outlet ports. Figure 4 shows the thermocouple tree that was inserted through the fitting in the new lid. The arrows mark the thermocouple locations.

Figure 3. Custom Lid for Thermocouple Tree Access

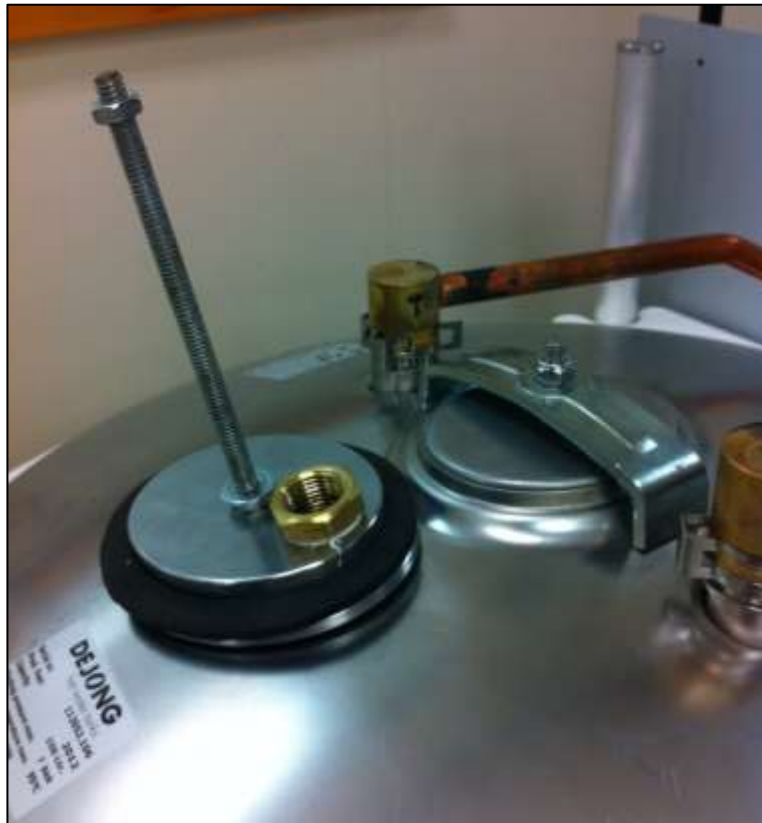
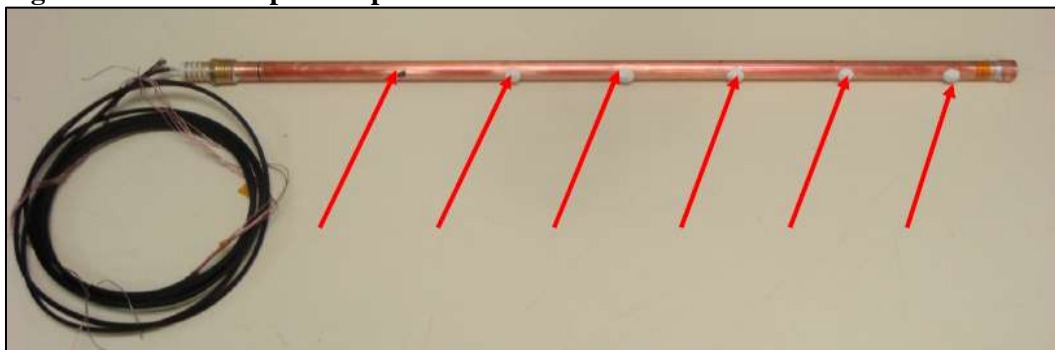
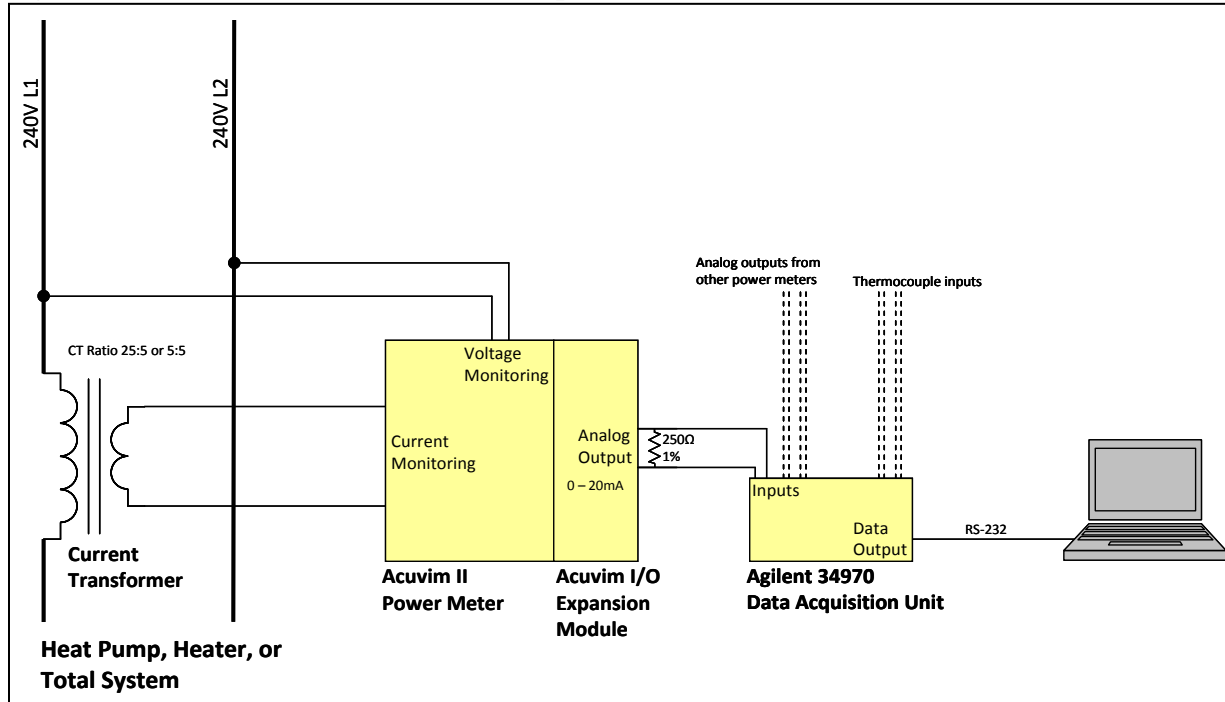

Figure 4. Thermocouple Temperature Tree



Cascade Engineering measured inlet and outlet water temperatures with thermocouples immersed in the supply and outlet lines. Three thermocouples mounted to the surface of the evaporator coil at the refrigerant inlet, outlet, and midpoint monitored the coil temperature to indicate the potential for frosting conditions. Cascade Engineering monitored power for the equipment for the entire unit including the compressor, fan, and pump all at once (Figure 5). Cascade Engineering made a series of one-time power measurements for other loads, including the control board and the fan. Appendix B provides a complete list of sensors, including others in addition to those mentioned here, plus their rated accuracies.

Figure 5. Power Measurement and Data Acquisition Schematic



Cascade Engineering conditioned and stored tempered water in a large tank to be supplied to the water heater at the desired inlet temperature. A pump and a series of flow control valves in the inlet and outlet water piping control the water flow rate. A flow meter measures and reports the actual water flow.

A data acquisition (DAQ) system collects all the measurements at five-second intervals and logs them to a file. In a post processing step, Ecotope merged the temperature log of the thermal chamber with the DAQ log file to create a complete dataset for analysis.

Cascade Engineering conducted all tests to align with the DOE specifications, with the following exceptions:

- The tests placed the unit on top of a plywood and foam insulated test pad instead of the prescribed ¾” plywood and three 2x4 platform.

- The pump for conditioned water maintained the supply pressure near 20 psi rather than the 40+ psi of the spec.
- Water inlet and outlet supply piping consisted of the cross-linked polyethylene (PEX) variety rather than copper.
- The lab took inlet and outlet water temperature measurements two feet from the tank.

In all, Ecotope expects the deviations from the standard protocol to produce minimal differences in testing outcomes. If anything, it expects the differences in platform and piping to slightly reduce the heat loss rate of the tank, thereby improving performance.

3. Findings: Equipment Characteristics

3.1. Basic Equipment Characteristics

The GES HPWH is an all-electric water heater consisting of a heat pump integrated with a hot water storage tank. The equipment has a single method of heating water: using a heat pump to extract energy from the ambient air and transfer it to the water. In this case, the ambient air is defined as the air from wherever the inlet duct draws.

All of the equipment's active components – including the compressor, condenser, evaporator, fan, and water pump – are located in a single, cube-shaped module. The tank is in a similarly-shaped module and may be installed next to or underneath the heat pump. A pump in the heat pump module circulates water between the tank and the heat exchanger. All of the heat exchange takes place in the heat pump module.

A variable-speed, centrifugal fan draws air in through an eight-inch diameter port, across the evaporator coils where it absorbs heat from the air stream, and discharges colder air through a different eight-inch diameter port. The installer can connect ducting to the ports to direct the airflow. The CO₂-based refrigerant cycle transfers the heat to the condenser side of the unit, which is in thermal contact with the water through a double wall heat exchanger. The water pump pulls cold water out of the bottom of the tank, across the condenser, and re-injects hot water into the top of the tank. Notably, the equipment heats the water from cold to hot in a single pass.

The lab conducted a series of measurements comprising a basic descriptive characterization of the equipment. These measurements are shown in Table 1 and are discussed in the rest of this section.

Unlike traditional electric tank water heaters, the GES contains no electric resistance heating elements. The water heater heats solely with a variable-speed, inverter-driven compressor. Measurements show that the heating module, including compressor, fan, and water pump, draws 1.0 kW to 2.0 kW depending on both tank water and ambient air conditions. The compressor increases speed, and therefore power draw, as the ambient temperature decreases in order to maintain heating output capacity. At 67° F, the compressor unit draws 1.0 kW for most of the heating cycle. As the overall water temperature in the tank increases, the power draw increases as well to 1.5 kW. At 30° F, the unit draws 2.0 kW for most of the cycle, ending with 2.2 kW.

Two other components of the equipment also consume power: the centrifugal fan and the water circulation pump. Both components run concurrently with the compressor and their power draw is included in all the measurements. Like the compressor, the fan is also variable-speed. The lab conducted tests to measure airflow and power over a range of duct configuration scenarios. In the simplest scenario, with no ducting and air temperatures near 65° F, the fan drew 35 W. Fan power generally decreases as the static pressure inside the duct increases, but increases as the air temperature decreases. The lab did not independently measure the pump power draw. Last, measurements of standby power show the unit uses <1 W when idle.

The GEU-15QTA tank has a nominal 150- liter (39.7-gallon) capacity. Measurements showed the unit in the lab held 39.7 gallons.

The GES uses R-744 refrigerant, otherwise known as CO₂. R-744 offers some distinct advantages over two typically-used HPWH refrigerants: R-410a and R-134a. R-744 has a broader range of operating temperatures, making it well-suited for use as the energy exchange medium between cold outside air temperatures and hot tank water temperatures. Lab tests showed the equipment had no difficulty heating the tank water to 149° F at an intake air temperature of 30° F; this corresponds to a 132° F temperature lift. R-744 also has a Global Warming Potential (GWP) of 1, in contrast to GWPs of 2,000 for R-410a and 1,320 for R-134a.

Table 1. Basic Characteristics for Sanden GES

Component	Measurement / Description
Resistance Elements	None
Heat Pump* (W)	1,000 - 2,200
Fan** (W)	35
Standby (W)	< 1
Tank Volume (Gallons)	39.7
Refrigerant	R-744 (CO ₂)
Airflow Path	Inlet and exhaust on top through separate eight-inch-diameter ports
Dimensions (per module)	31" Wide x 27" Deep x 38" High

Notes: *Includes compressor, circulation pump and fan. Range depends on water and ambient temperature.

**Measured at max flow with no ducting attached

To characterize the fan airflow and power, Cascade Engineering measured those values over a range of static pressures. **Figure 6** shows the test setup and illustrates the ducting connections. The manometer and flow measurement station are attached to the outlet airflow side. The HPWH uses a damper on the outlet side to change the static pressure. **Figure 7** shows the fan characteristics and also displays the functional curve fits for flow and power in terms of static pressure. Those relationships predict the airflow for any given set of duct configurations. Although fan affinity laws state that the airflow is proportional to the square of static pressure, simple linear functions fit the data well. At a little more than 0.25” (62 Pa) of static pressure, the fan is not able to push more air.

Figure 6. Fan Test Setup and Duct Connections



Figure 7. Fan Characteristics

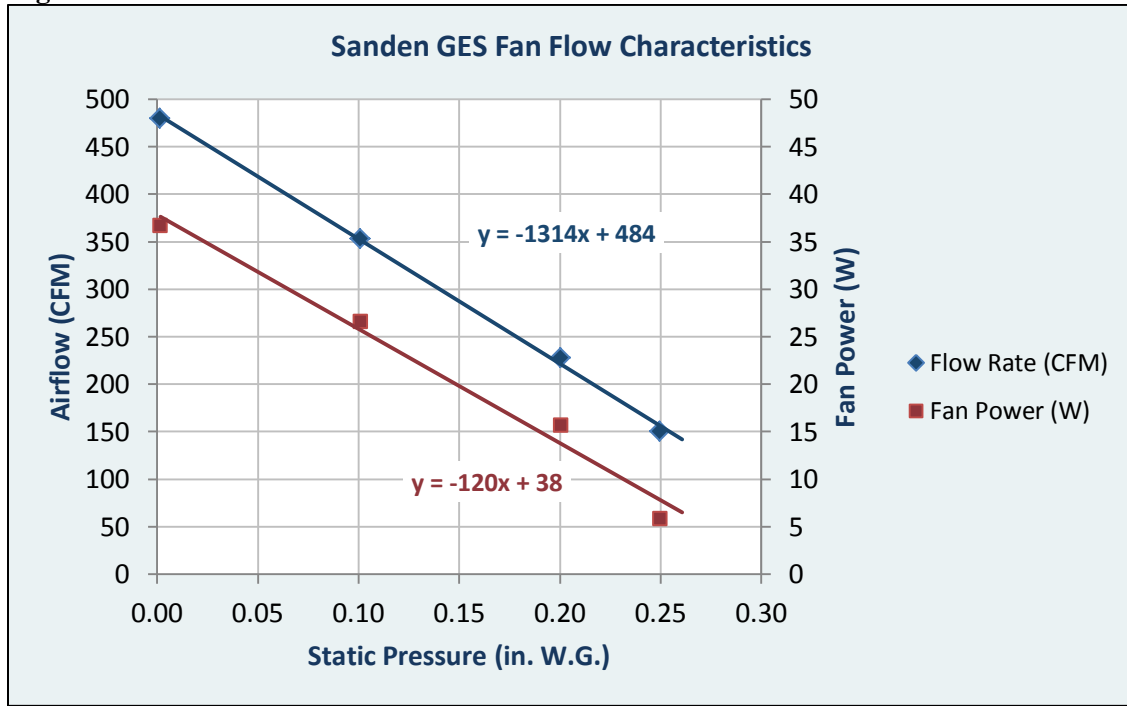

3.2. Operating Modes and Sequence of Heating Firing

The HPWH has an integrated circuit control board, located in the compressor unit, which can be programmed in a number of ways to control when the heat pump turns on and off. Sanden has developed two control strategies for the unit, which it references as modes: “comfort” mode and “eco” mode. Cascade Engineering conducted all of the lab tests in comfort mode.

The current version of the tank controls has a fixed temperature setpoint of 149° F (65° C); this setpoint is not user-adjustable. Figure 8 shows the location of the two thermistors monitoring the tank temperature.

Figure 8. Tank Thermistor Heights

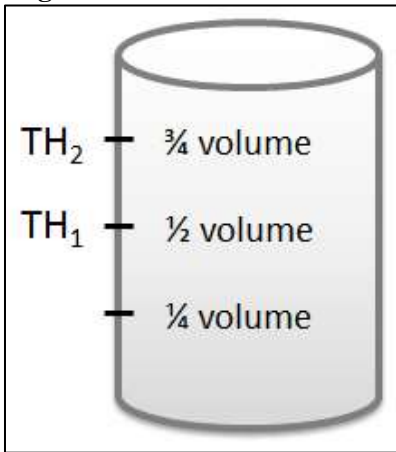

Comfort Mode: Comfort mode is designed to reheat the tank as soon as the internal tank temperature drops significantly. When TH₁ senses a temperature below 113° F, the heat pump turns on to reheat the tank to setpoint (149° F). The compressor speed is controlled such that the nominal heating capacity is 4.5 kW in this mode.

Eco Mode: Eco mode is designed for heating the water in off-peak electricity times such as during the night. The user programs the time intervals for when he or she wants the water heater to operate. When operating, the tank heats to 149° F. To supplement the Eco mode schedule, “boost” heating is possible at any time of the day when requested by the user (he or she presses a button on the tank to activate it). For the boost, the tank starts to heat if TH₂ is below 113° F, but then stops when TH₁ is 113° F or above. Eco mode controls the compressor speed such that the nominal input capacity is 3.5 kW. The lower capacity requires a lower power input, which can be another way to limit demand during a peak electricity period.

4. Findings: Testing Results

4.1. First Hour Rating and Energy Factor

The DOE has established two tests to rank the comparative performance of HPWHs. The first (1-hour) test produces a first hour rating that determines how much usable hot water the heater makes in one hour. The second, a 24-hour simulated use test, produces an energy factor (EF) that identifies how much input energy is needed to generate the 64.3 gallons of hot water used in the simulated 24-hour period. For tank-type water heaters, the first hour rating depends largely on tank volume and heating output capacity, while the EF depends on the heating system efficiency and the heat loss rate of the tank. The normative performance characteristics of the equipment are shown in Table 2 and are discussed in the rest of this section. Although the lab carried out the tests to align with the DOE specifications, the outputs here should be considered advisory only – any official ratings are those reported by the manufacturer.

The lab conducted these tests with the GES in “Comfort” mode, as described in Section 3.2. The results are shown in Table 2. A key item to note for these tests is that the tank setpoint was fixed at 149° F instead of at the normative 135° F value. If anything, Ecotope expects that testing at a lower setpoint would lead to improved performance. In addition to performing the tests at the standard rating conditions, Cascade Engineering conducted several other similar tests. The second EF-type test used the same methods and draw patterns, but used different environmental conditions of 50° F ambient air / 50° F inlet water – the conditions used to determine the Northern Climate Energy Factor.

Table 2. Performance Characteristics for Sanden GES HB50

Metric	Measured Value
First Hour Rating (gal)	58
Energy Factor (std. conditions)	3.39
Energy Factor @ 50° F Ambient	2.8
Northern Climate Energy Factor	2.98
Tank Heat Loss Rate (Btu/hr° F)	2.2

4.1.1. 1-hour Test

The data from the 1-hour test are plotted in Figure 9. The test begins with a 3 gpm draw. Approximately eight minutes into the first draw, the temperature halfway up the tank falls below 113° F, activating the heat pump (green line showing 1.1 kW). As the draw continues past twenty-five minutes, the water temperature at the outlet has fallen more than 25° F, so the first draw is terminated. The heat pump continues to heat the tank until the sixtieth minute. This time point (per the DOE test method) triggers the final draw, which terminates when the outlet temperature again drops below 124° F (25° F below the setpoint).

The Northern Climate Specification uses the 1-hour test data to determine how many gallons of hot water are withdrawn in the first draw before the resistance element turns on – a critical indicator of overall operational efficiency for hybrid heat pump water heaters. This tank, with no resistance elements, can provide forty-one gallons of hot water in the first draw, all of which is

heated with the heat pump. Further, even though the lab used a tank setpoint of 149° F instead of 135° F for this test, it kept the draw termination conditions the same, at 25° F below the setpoint. Therefore, the test results would likely be nearly unchanged if the tank setpoint were 135° F.

Figure 9. DOE 1-Hour Test

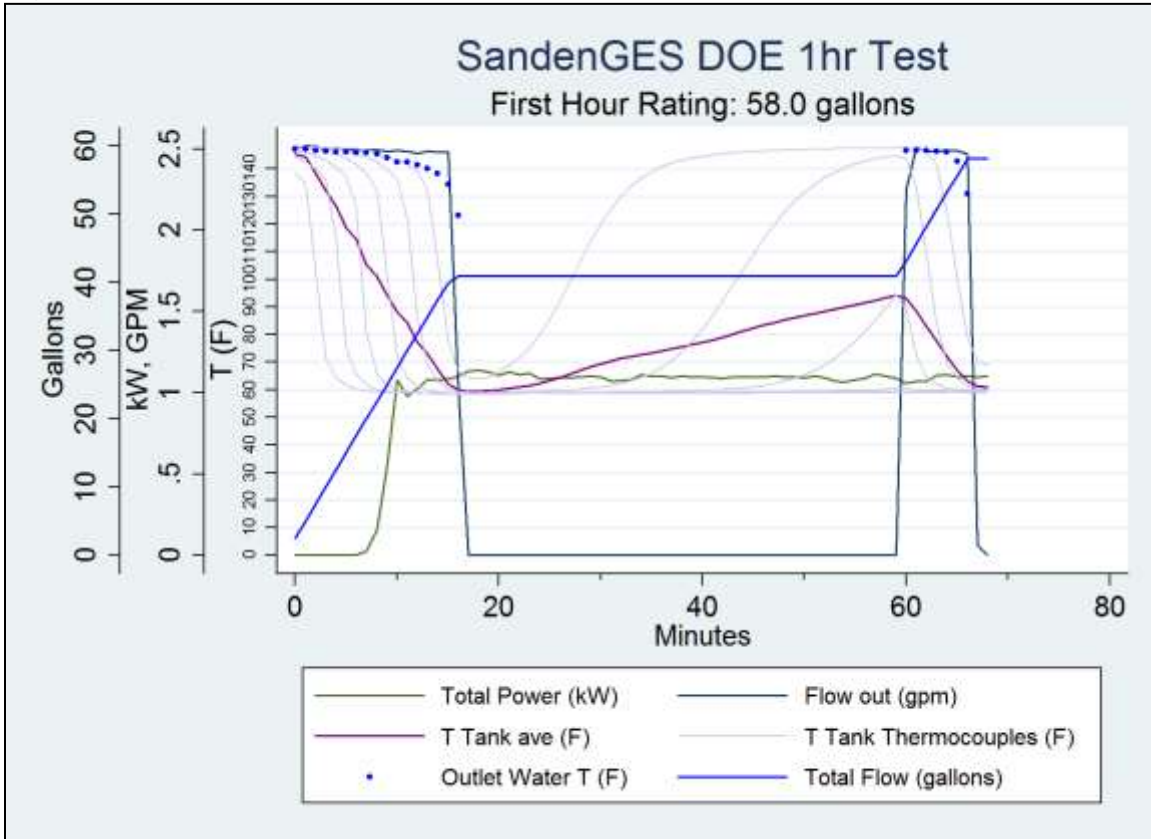

Notes: The bright blue line shows the cumulative water drawn during the test. The green line plots the total equipment power consumption. The thick purple line displays the average tank temperature, while the thin lavender lines show the temperatures reported from the six thermocouples placed at different heights (corresponding to equal volume segments) within the tank (in effect a temperature profile of the tank at any point in the test). Lastly, the blue dots plot the outlet water temperature.

4.1.2. Energy Factor Tests

The 24-hour simulated use test consists of six 10.7-gallon draws equally spaced over six hours, followed by eighteen hours of standby. The standard test conditions are 67.5° F, 50% relative humidity (RH) ambient air, 135° F tank setpoint and 58° F incoming water temperature. As with the first hour rating, the lab used the equipment in auto operating mode. The lab also performed the 24-hour simulated use test at colder ambient conditions of 50° F ambient air and 50° F inlet water. As part of the Northern Climate Heat Pump Water Heater Specification, the test results demonstrated the variation in performance with varied ambient conditions.

The EFs used for all the tests are displayed above in Table 2. They are calculated with the DOE method but with different ambient conditions where relevant for the 50° F ambient test. The Northern Climate Heat Pump Water Heater Specification provides a calculation method for determining the Northern Climate Energy Factor (EF_{NC}); it is a weighted combination of the EF

at 67° F and 50° F using a temperature bin profile. The procedure also uses the lowest ambient temperature at which the compressor no longer operates. For the temperature bins below that cutoff, the procedure assumes performance equal to that of resistance heating. The higher the compressor cutoff temperature, the lower the overall EF_{NC} will be (for details, see the Northern Climate Heat Pump Water Heater Specification). In the calculations, Ecotope used the 5° F temperature bin cutoff as determined through discussions with the manufacturer.

Figure 10 shows the first six hours of the test to allow examination of the draw events and recovery in more detail. Figure 11 shows the full 24 hours, which also illustrates the tank heat loss rate. These two figures plot the same type of data as Figure 9.

Figure 10 also plots the instantaneous coefficient of performance (COP), a measure of the amount of heat added to the hot water in a given time interval divided by the energy used to create or deliver that heat in that interval (in this case five minutes). The COP for electric resistance heat is generally assumed to be 1.0; in contrast, the COP for heat pumps can vary greatly, depending largely on the ambient air conditions (heat source) and the tank temperature (heat sink). The downward trend of the COP in Figure 10 toward the end of each recovery cycle reflects the warming tank temperature. The scatter in the COP plots is due to uneven fluctuations in the tank temperature measurements, but the general trend is clear. The COP hovers near 4.3 for most of the period and then drops to 1 as it tops off the tank temperature (the heat pump is less efficient when working against a larger temperature difference).

Figure 12 and Figure 13 plot the heat pump behavior for the 50° F ambient air and 50° F inlet water 24-hour testing conditions. The graphs look nearly identical to those plotted for 67° F ambient air, with the exception that the input power is higher (1.5 kW) and the COP is lower (3.7). The equipment controls are ramping up the compressor speed to maintain exactly the same heating output despite a lower ambient air temperature. In fact, the tests at both temperatures yielded runtimes near 200 minutes, with the compressor in the 67° F test running about 1.5% longer than that in the 50° F test.

Figure 10. DOE 24-Hour Simulated Use Test, First Six Hours

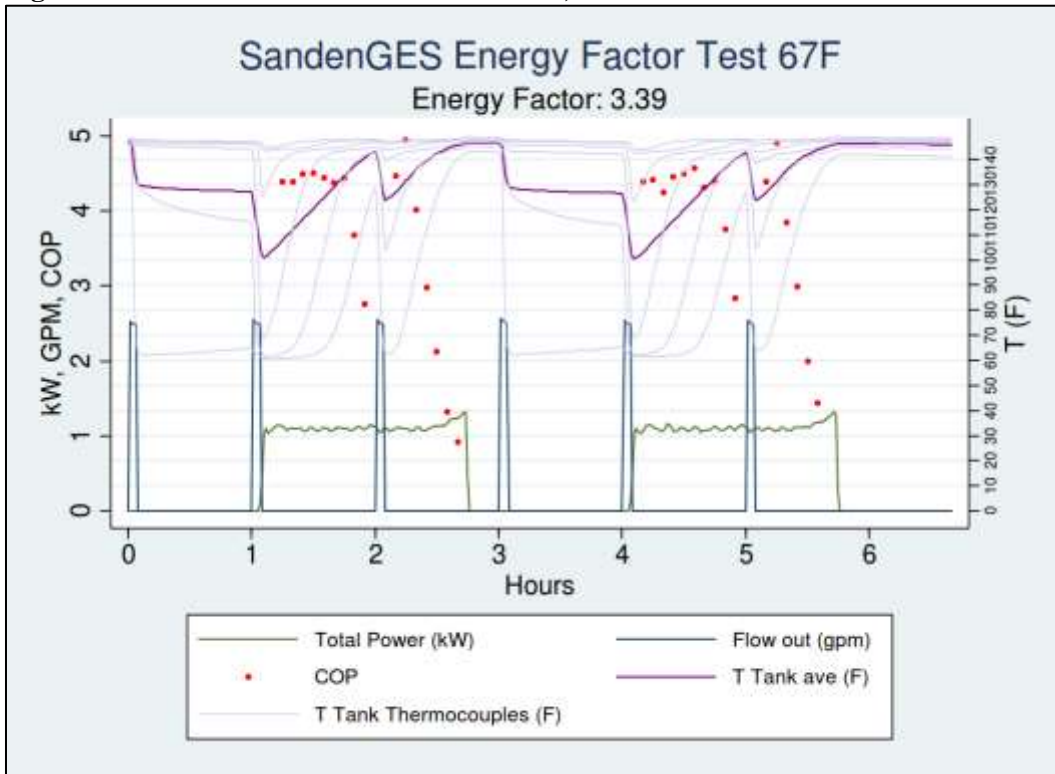

Figure 11. DOE 24-hour Simulated Use Test, Full 24 Hours

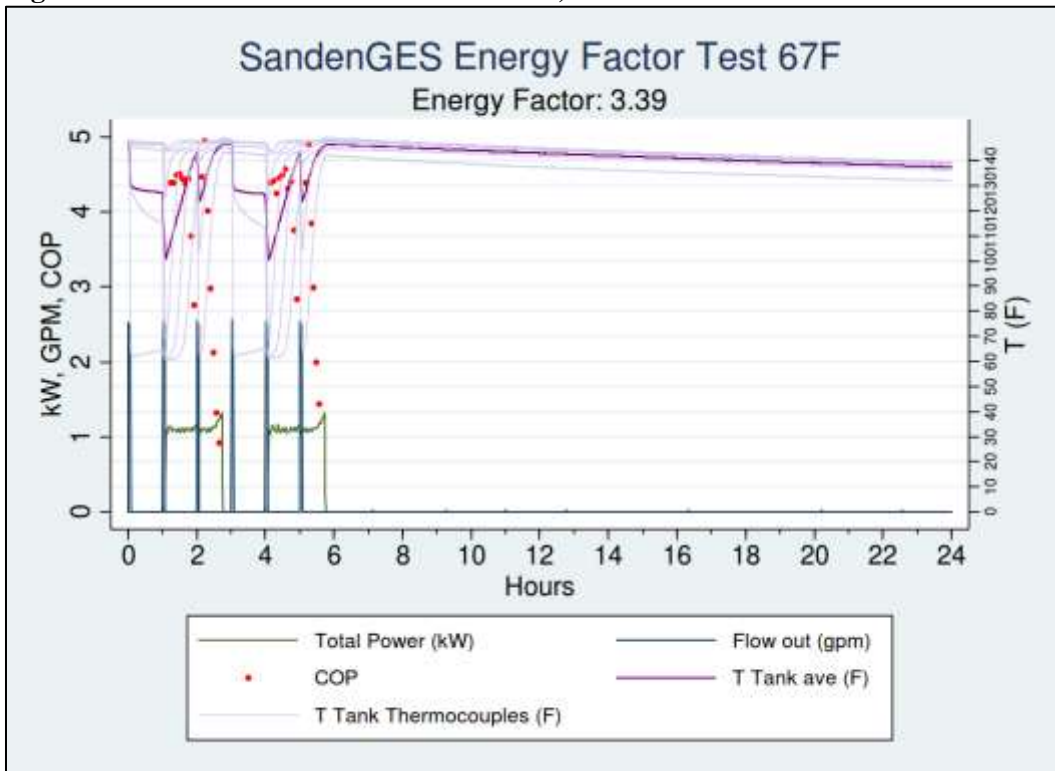

Figure 12. DOE 24-hour, 50° F Ambient Air 50° F Inlet Water, First Six Hours.

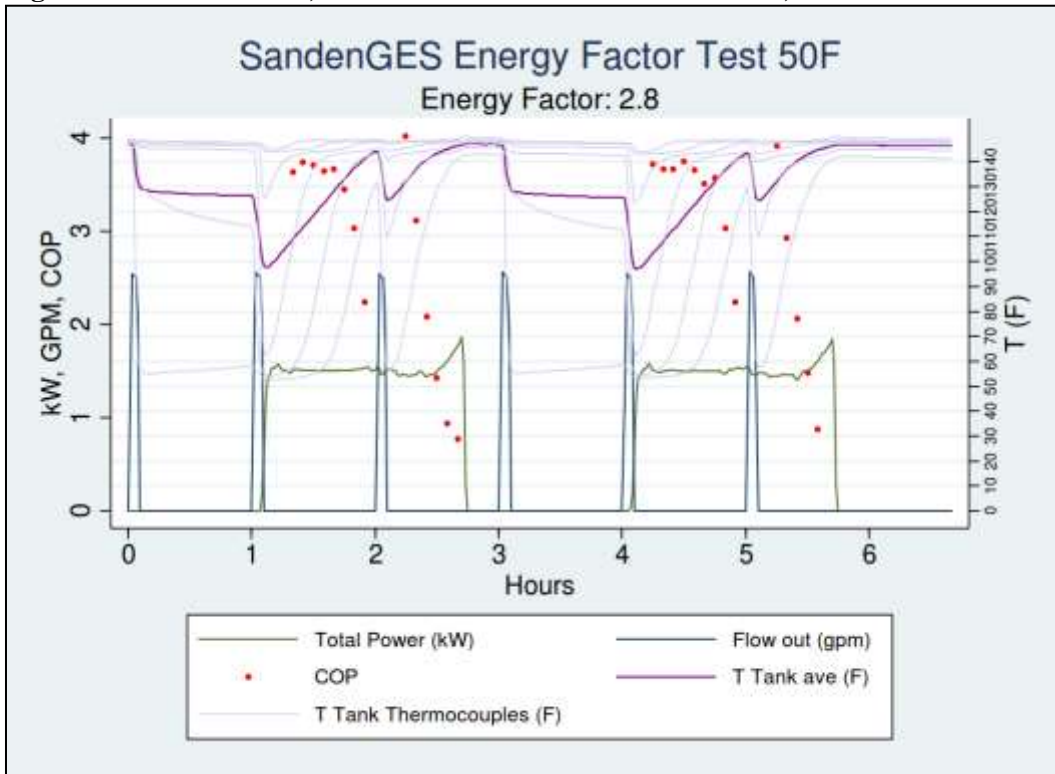
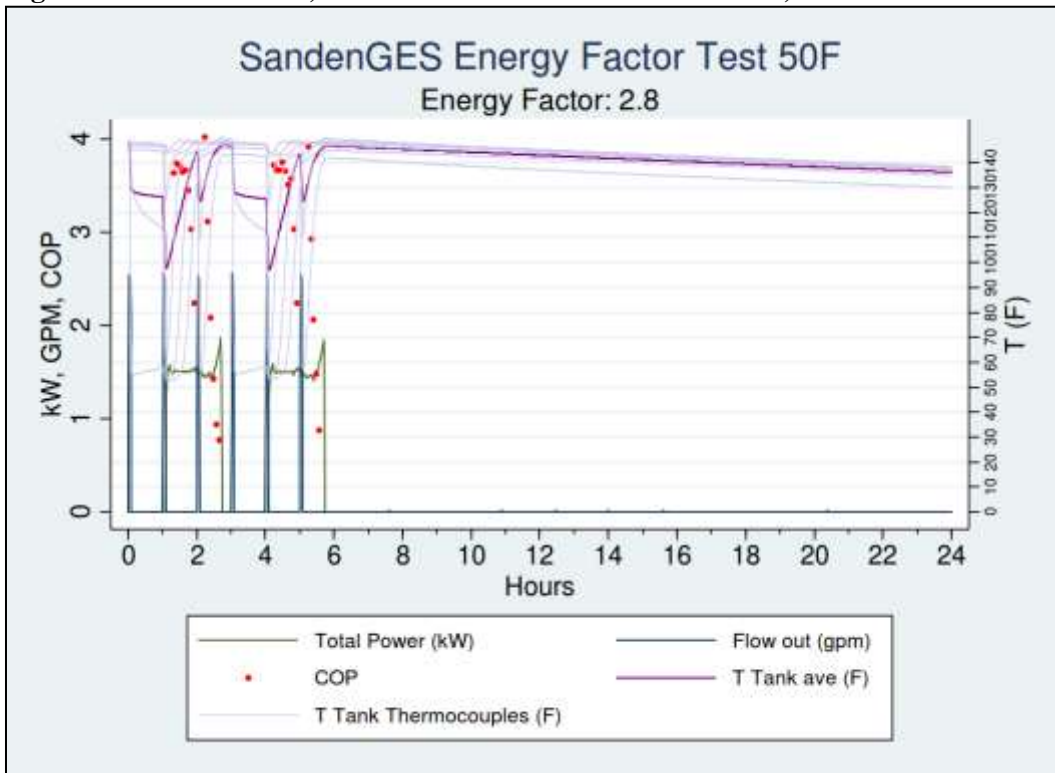

Figure 13. DOE 24-hour, 50° F Ambient Air 50° F Inlet Water, Full 24 Hours.



4.2. Efficient Showers Test

In addition to the standard and modified DOE tests, the Northern Climate Specification calls for a delivery rating test to aid in better understanding performance. This simulated-use “Shower Test” (DP-SHW) describes the number of efficient hot showers the HPWH is capable of providing. The test specification is for 50° F ambient air, 50° F inlet water, and setpoint of 120° F. The Sanden GES test setpoint is 149° F. To mimic a series of morning showers, the lab conducted repeated eight-minute draws at two gallons per minute. The draws were separated by a five-minute lag time and continued until either the resistance element activated or the outlet temperature fell below 105° F. When one of these events occurred, the test allowed the current draw to finish, the tank to recover, and then the test concluded. Based upon the findings of this test, the GES water heater provides five consecutive efficient showers. The results of the test are displayed in Figure 14.

If the tank temperature were set at 120° F per the usual test specifications, the temperature drop below 105° F would happen earlier, resulting in a lower shower delivery rating. The point at which the outlet drops 15° F on the graph occurs during the fourth shower. Consequently, the shower delivery rating will likely be approximately four under standard test conditions.

If, however, the tank were kept at the higher temperature and mixed with cold water down to 120° F, it would produce more showers. This is the design of other Sanden HPWHs and is the manner in which the GES is installed in current markets.

Figure 14. Shower Test Supplemental Draw Profile

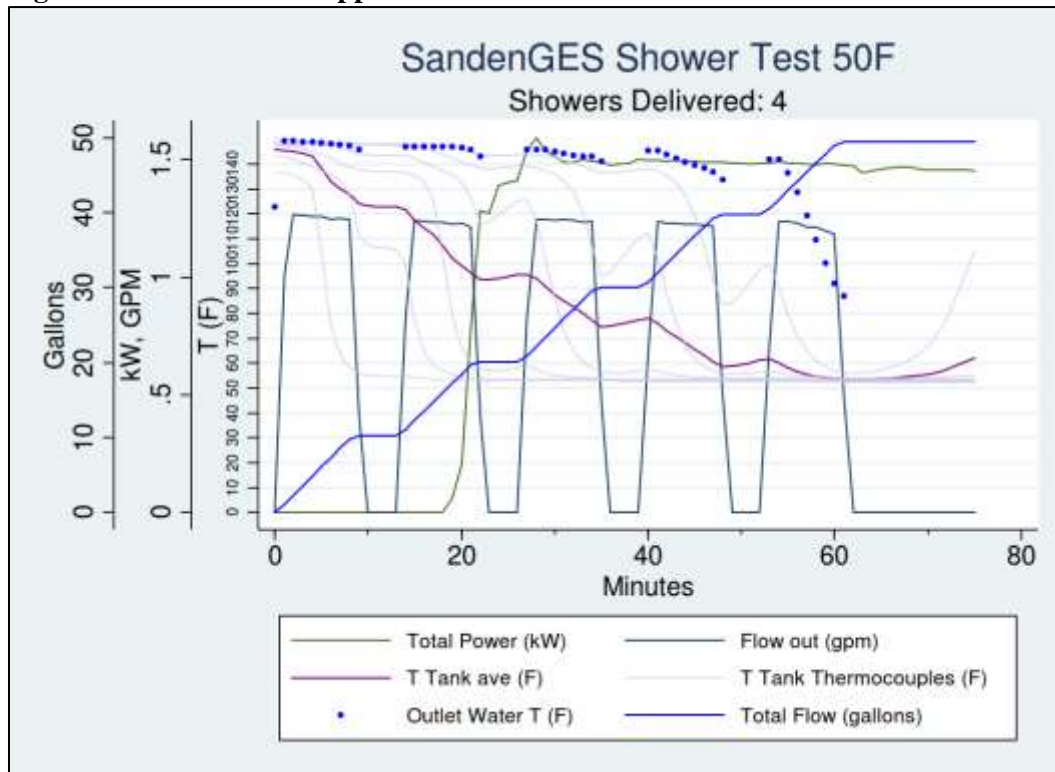

Both the DOE 1-hour and number of showers tests amount to delivery ratings. The Uniform Plumbing Code (UPC) (Uniform Plumbing Code 2009) uses the 1-hour test output (the first hour rating) for tank sizing requirements. Crucially, neither the UPC nor the DOE 1-hour test addresses the efficiency with which that first hour rating is obtained. Indeed, the delivery rating efficiency of older water heating technologies, including electric resistance and gas-fired tanks, turned out to be largely irrelevant. Those tanks, with only one means by which to heat water, could use two outputs from the DOE 24-hour test – the recovery efficiency and energy factor – to reliably describe the operational efficiency during the 1-hour tests. In contrast, typical hybrid HPWHs have two distinct heating efficiencies depending on which of the two heating methods the control strategies use. Further, the heat pump efficiency changes over the course of a test. Consequently, the number of showers test provides additional insight into how much hot water the tank can *efficiently* deliver. The Sanden GES differs from other HPWHs in that it only has a single heating method -- thus it always delivers water in the most efficient way.

The UPC requires a minimum capacity (first hour rating) for a water heater based on number of bathrooms and bedrooms. Both are proxies, respectively, for water demand and number of people in a house.¹ The UPC requires a minimum first hour rating of sixty-seven gallons for three bedrooms and two to 3.5 baths. The next-lower rating of fifty-four gallons covers three bedrooms with up to 1.5 baths, or two bedrooms with up to 2.5 baths. The GES's first hour rating of fifty-eight gallons shows that it can satisfy the latter of the two sizing scenarios in the UPC. If the installer chooses to pursue Sanden's intended design strategy of tempering the hot water outlet with a mixing valve, the tank could easily attain a sixty-seven gallon first hour rating. Regardless, the number of showers test demonstrates that the water heater will always meet that load with the efficiency of its heat pump system

4.3. Low Temperature Limit

The GES's lack of a resistance element backup underscores the importance of knowing the ambient air temperature lower operating limit before deploying these in the field. The lab testing observed compressor operation at 30° F but did not simulate any colder temperatures. The specification sheet from Sanden suggests the equipment will run to 5° F (-15° C). Further, the manufacturer reports that it has observed heat pump operation at 4° F. The lab testing does not contradict that statement. Ecotope observed no difficulty in compressor operation at 30° F, lending support to the lower, 5° F cutoff.

4.4. Compressor Output Capacity and Efficiency

To better understand the HPWH's performance, the testing plan called for mapping the compressor heat pump COP at varied tank temperatures and ambient air conditions. These COP measurements reflect how efficiently the heat pump components of the HPWH are operating under any given set of conditions. The COP test begins with the tank full of 55° F water. The heat pump is then turned on and the tank heats up to near setpoint (149° F). During the test, data loggers record the change in tank temperature (equivalent to output energy) and the equipment input energy. The quotient of the two is the COP.

¹ The number of people in a house is often taken to be number of bedrooms plus one. For an example, see ASHRAE Std. 62.2.

Figure 15 plots the COP test at 50° F ambient temperature. As alluded to earlier in this report, the actual COP points plotted are sometimes deceiving owing to the nature of the measurement system. The tank is highly stratified in temperature – so much so that one can think of a sharp line demarcating the boundary between cold and hot water (the thermocline). The output capacity is calculated via the change of tank temperature as measured by six evenly-spaced thermocouples. As the thermocline moves through the tank, those thermocouples experience alternately rapid and slow changes in temperature. This uneven pace produces the apparent oscillation in the COP plots until the very bottom thermocouple is heated up and the tank is at a near uniform temperature.

Figure 15 illustrates the COP test at 50° F, which starts with the tank at 55° F and finishes 120 minutes later with a hot tank. After the heat pump activates, the thermocline of hot water moves down the tank starting with thermocouple six (TC6) at the top, then to thermocouple five (TC5), and so on.

Figure 15. COP Test at 50° F

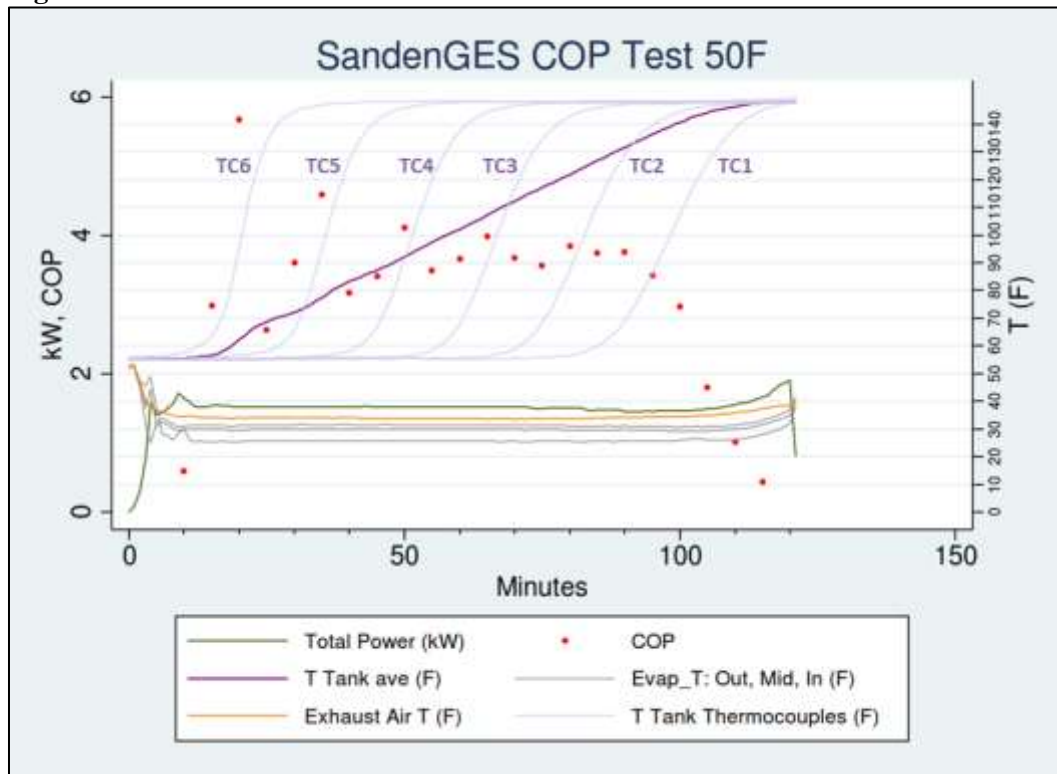

As the next analytical step, the data from Figure 15 is plotted over the entire heating cycle for all the ambient temperatures (as in Figure 16) to show the relationships among temperature, COP, and heating capacity. The relevant water temperature for this heat pump is that at the bottom of the tank, which is piped to the condenser. The top three sets of lines represent the capacities and are plotted on the left axis. The bottom three lines represent the COPs and are plotted on the right axis. The 55° F condenser temperature appears to show a range of COPs and capacities, but that

is misleading. The apparent range is due to the measurement artifacts discussed previously in this section. The actual COPs for most of the heating cycle are given in Table 3 under the “Beginning and Middle Heating Cycle” heading. For most of a reheat cycle, the efficiency and output are stable. Only when the final segment of water gets heated does the COP change. That effect is also captured in Table 3 under the “Full Heating Cycle...” heading.

Remarkably, the heating capacity doesn’t change significantly for different ambient air conditions. Further, the heating output of 18,000 Btu/hr is equivalent to 5.3 kW, which is more than a standard resistance tank. The higher output means the tank can recover more quickly.

Table 3. COP and Capacity Measurements

Ambient Air Temperature	Beginning and Middle of Heating Cycle		Full Heating Cycle Including Final Rise to Setpoint	
	COP	Capacity (Btu/hr)	COP	Capacity (Btu/hr)
30° F	2.73	18,100	2.40	15,800
50° F	3.66	18,900	3.21	16,500
67° F	4.21	18,200	3.67	15,900

Figure 16. COP and Heating Output Capacity: 30° F, 50° F, and 67° F

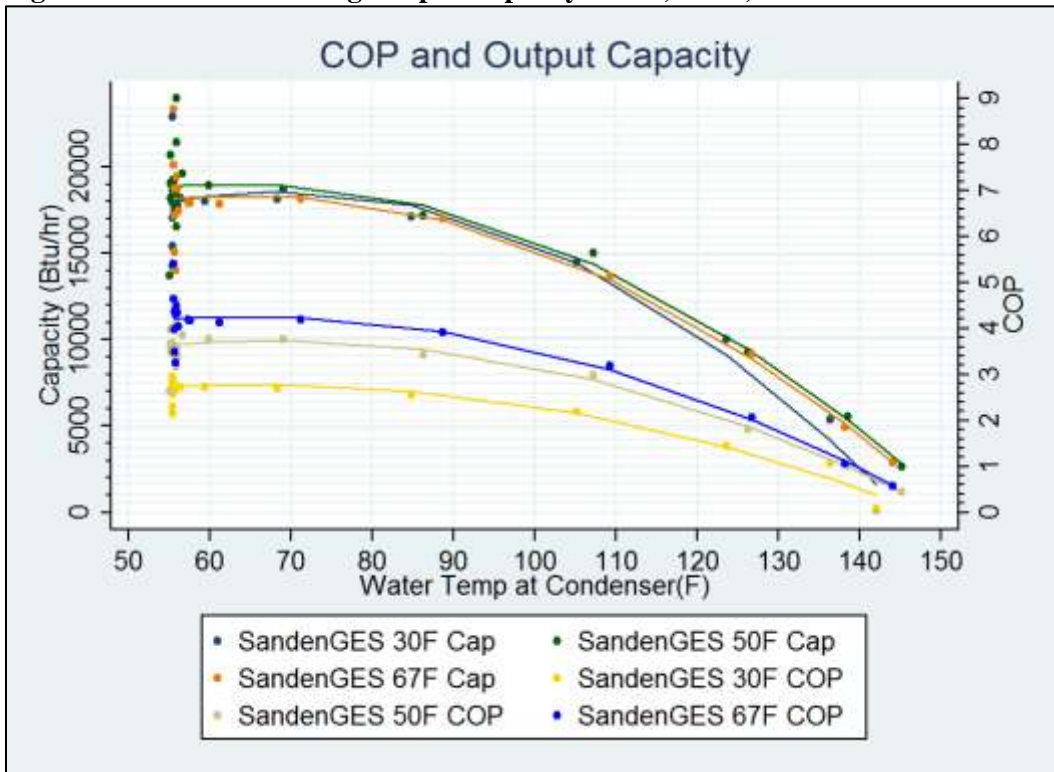

4.5. Noise Measurements and Additional Observations

The lab also measured the sound level of the equipment. Researchers placed the unit in a room near a wall and then measured the sound level at five different points on a circumference three feet distant and five feet high. The researchers repeated the measurement for the equipment modules installed in both side-by-side stacked configurations. The ambient temperature for the test was ~72° F. Table 4 shows the background noise levels and the averages of the five measurements. The results show that the two configurations have slight differences in the sound levels.

Table 4. Sound Level Measurements for Sanden GES

Decibel Weighting	Background	HPWH on Side-by-Side	HPWH on Stacked
dBA	35.4	48.0	44.2
dBBC	60.3	62.9	65.7

The lab also observed the condensate collection pan and drainage path throughout the testing process. The pan collected and drained condensate as expected. The lab observed no blockages, overflows, or adverse outcomes.

5. Conclusions

This final section of the report discusses observations, in no particular order, on the equipment design and their implications for operation and performance.

- The tank is well-insulated and the heat pump system is efficient. With its modular design, the evaporator heat exchanger has a much larger area than typical integrated HPWHs.
- The compressor output of nearly 5.3 kW is larger than that of a typical resistance heating element. With the heat pump, it uses less input power and heats water more quickly, potentially improving a consumer's hot water experience.
- The inverter-driven, variable-speed compressor and fan are efficient and maintain heating output capacity as the ambient temperature decreases. Measured COPs ranged from 2.4 at 30° F to 3.7 at 67° F. As the source air temperature drops, the compressor speeds up. The equipment efficiency decreases, but the capacity is held constant.
- This HPWH uses carbon dioxide (CO₂) refrigerant, also known as R-744, which is widely used in Japan as a response to climate change. The Global Warming Potential (GWP) of CO₂ is 1, as opposed to 2,000 for R-410a and 1,320 for R-134a, two typically-used refrigerants. R-744 also offers distinct thermodynamic advantages over R-410a and R-134a. It has a broad range of operating temperatures, making it well-suited for use as the energy exchange medium between cold air temperatures and hot tank water temperatures. Tests showed that the equipment had no difficulty heating the water to 149° F with a source air temperature of 30° F. Further, the manufacturer reports operation to at least 5° F.
- Both the supply and exhaust air may be ducted, offering numerous installation possibilities. Given the wide temperature operating range, the supply air can even be drawn from outside for installations in the more temperate Pacific Northwest climates. With its broad operating range and ducting possibilities, this HPWH is well-suited for all climates across the Northwest.
- This HPWH has no resistance element or any backup system. It is designed to always heat with the compressor. The strategy offers significant efficiency advantages because no chance exists for a complex draw pattern or control strategy to trigger resistance heat, as can happen with hybrid HPWHs. At the same time, the absence of a backup heating method is of potential concern in the event of compressor failure or of seriously cold source air temperatures, which may prevent the refrigeration cycle from operating.
- The unit supplied by Sanden is designed for the European market with design considerations specific to that market. The stainless steel tank is relatively small, at forty gallons. The water heater also has a fixed temperature setpoint of 149° F. These features led the lab to adapt some of the standard testing procedures. A tank targeted for the United States market would likely have a somewhat different configuration.

References

- ASHRAE. 2010. *ASHRAE Standard 62.2-2010. Ventilation and Acceptable Indoor Air Quality in Low-Rise Residential Buildings*. Atlanta, GA: American Society of Heating, Refrigerating and Air-Conditioning Engineers, Atlanta, GA:
- ASHRAE. 2006. *ASHRAE Standard 118.2-2006. Method of Testing for Rating Residential Water Heaters*. Atlanta, GA: American Society of Heating, Refrigeration and Air Conditioning Engineers.
- DOE. 1998. US Department of Energy 10 CFR 430. Federal Register May 11, 1998 Part 430. *Energy Conservation Program for Consumer Products: Uniform Test Method for Measuring the Energy Consumption of Water Heaters* pp. 26008-26016. Retrieved from http://www1.eere.energy.gov/buildings/appliance_standards/residential/pdfs/wtrhr.pdf
- Ecotope. 2010. *Residential Heat Pump Water Heater Evaluation Project Measurement & Verification Plan*. Prepared for Bonneville Power Administration. Retrieved from http://www.bpa.gov/energy/n/emerging_technology/pdf/HPWH_MV_Plan_Final_012610.pdf
- Larson, B., and Logsdon, M. 2011. *Residential Heat Pump Water Heater Evaluation: Lab Testing & Energy Use Estimates*. Prepared for Bonneville Power Administration Retrieved from http://www.bpa.gov/energy/n/emerging_technology/pdf/HPWH_Lab_Evaluation_Final_Report_20111109.pdf
- Larson, B., and Logsdon, M. February 2012. *Laboratory Assessment of AO Smith Voltex Hybrid Heat Pump Water Heater*. Prepared for the Northwest Energy Efficiency Alliance. Retrieved from: <https://conduitnw.org/layouts/Conduit/FileHandler.ashx?RID=888>
- Larson, B., and Logsdon, M. February 22, 2012. *Laboratory Assessment of AirGenerate ATI66 Hybrid Heat Pump Water Heater*. Prepared for the Northwest Energy Efficiency Alliance. Retrieved from: <https://conduitnw.org/layouts/Conduit/FileHandler.ashx?RID=887>
- Larson, B., and Logsdon, M. September 2012. *Laboratory Assessment of General Electric GeoSpring Hybrid Heat Pump Water Heater*. Prepared for the Northwest Energy Efficiency Alliance. Retrieved from: <https://conduitnw.org/layouts/Conduit/FileHandler.ashx?RID=1183>
- Larson, B. March 2013. *Laboratory Assessment of AirGenerate ATI80 Hybrid Heat Pump Water Heater*. Prepared for the Northwest Energy Efficiency Alliance. Retrieved from:

<https://conduitnw.org/layouts/Conduit/FileHandler.ashx?RID=1522>

- Larson, B. June 2013. *Laboratory Assessment of Rheem HB50RH Heat Pump Water Heater*. Prepared for the Northwest Energy Efficiency Alliance. Retrieved from: <https://conduitnw.org/layouts/Conduit/FileHandler.ashx?RID=1646>
- Northwest Energy Efficiency Alliance. 2012. *Northern Climate Heat Pump Water Heater Specification*. Retrieved from <http://neea.org/northernclimatespec/>
- Sparn, B., Hudon, K., and Christensen, D. 2011. *Laboratory Performance Evaluation of Residential Integrated Heat Pump Water Heaters*. Technical Report: NREL/TP-5500-52635. National Renewable Energy Laboratory. Retrieved from <http://www.nrel.gov/docs/fy11osti/52635.pdf>
- Uniform Plumbing Code. 2009. *2009 Uniform Plumbing Code*. Ontario, CA: International Association of Plumbing and Mechanical Officials. Retrieved from <http://ia600405.us.archive.org/24/items/gov.law.iapmo.upc.2009/iapmo.upc.2009.pdf>

Appendix A: Testing Matrices

Testing Matrix: Sanden GES

DOE Standard Rating Point Tests

Test Name	Ambient Air Conditions					Inlet Water		Outlet Water		Airflow	Operating Mode	Notes
	Dry-Bulb		Wet-Bulb		RH	F	C	F	C	inch. static pressure		
	F	C	F	C								
DOE-1-hour	67.5	20	57	14	50%	58	14	149	57	0.0"	"Comfort"	Follow test sequence in Federal Register 10 CFR Part 430 Section 5.1.4
DOE-24-hour	67.5	20	57	14	50%	58	14	149	57	0.0"	"Comfort"	Follow test sequence in Federal Register 10 CFR Part 430 Section 5.1.5
DOE-24-hour-50	50	10	44	7	58%	50	10	149	57	0.0"	"Comfort"	Follow test sequence in Federal Register 10 CFR Part 430 Section 5.1.5, but replace ambient conditions with those given in this table.

Draw Profiles

DP-SHW-50	50	10	44	7	58%	50	10	120	49	0.0"	"Comfort"	Draw Profile: DP-SHW. Conduct identical, repeated draws until ending conditions observed.
-----------	----	----	----	---	-----	----	----	-----	----	------	-----------	---

COP Curve – Performance Mapping

COP-30	30	-1	28	-2	80%	55	13	149	65	0.0"	"Comfort"	Start with tank off and water at 55° F. Turn tank on and observe efficiency over heating cycle.
COP-50	50	10	44	7	58%	55	13	149	65	0.0"	"Comfort"	
COP-67	67.5	20	57	14	50%	55	13	149	65	0.0"	"Comfort"	

Airflow Measurement

AM	UUT has multiple ducting options. Perform tests with exhaust duct only and with both supply and exhaust connected. Temperature and humidity need not be tightly controlled. They can be room conditions which might approximate DOE standard conditions.									0.0" to 0.75"	"Comfort"	Map fan power and airflow w/ duct connected to exhaust. Vary static pressure with damper at outlet. Measure at static pressures: 0.0, 0.1, 0.2, 0.25, 0.35, 0.5, 0.75
----	--	--	--	--	--	--	--	--	--	---------------	-----------	---

Additional Observations

AO-VOL	Measure tank water volume											
AO-PWR	One-time measurements of component power										"Comfort"	Make measurement of fan, pump, & circuit board power draw if possible.

Noise Measurement

NOI	Measure combined fan and compressor noise									0.0"	"Comfort"	Install equipment in relatively quiet room. Measure sound at 1 meter away, 1.8 meters high at several points around circumference of tank using a hand-held meter.
-----	---	--	--	--	--	--	--	--	--	------	-----------	--

Appendix B: Measurement Instrumentation List

Equipment	Make and Model	Function	Accuracy	Calibration Expiration Date
Walk-in Chamber	Make : ESPEC, Model No.: EWSX499-30CA	Test environment temperature and relative humidity control	± 1 °C	8/13/2013
Data Acquisition System	Make : Agilent Technologies, Model No : Agilent 34970A	Log temperature, power, and flow rate data	Voltage: 0.005% of reading + 0.004% of range Temperature: (Type T):1.5° C	7/31/2013
Thermocouple	OMEGA, T type	Temperature measurement	0.8 °C	Note 1
Power Meter	Acuvim II – Multifunction Power Meter with AXM-I02 I/O Module	Continuous power measurement as necessary (system, heater, and heat pump)	Main Unit: 0.2% full scale for voltage and current AXM-I02 Analog Output: 0.5% full scale + 1% resistor tolerance	Note 2
Power Meter	Voltech PM100 Single Phase Power Analyzer	One-time fan power measurement	Voltage: +/- 0.1% Current: +/- 0.1% Power: +/- 0.2%	10/5/2013
Flow Control	Control: Systems Interface Inc. Flow meter: Signet 2537 paddlewheel	Water draw rate and amount control	Note 3	Note 3
Electronic Scale	OXO “Good Grips” Scale	Measurement of water mass	5.0 Kg full scale with 1 g increment	8/16/2013
Hand-held Temperature and Humidity Meter	Omega RH820W	Lab environment temperature and humidity measurement	± 0.5 ° C	Note 6
Electronic Scale	Dymo Pelouze Model: 4040 Range 180 Kg	Measurement of water mass	± 0.2 Kg	Note 6
Air Flow Meter	Digital Pressure Gauge Model DG-2, Make: Energy Conservatory	Air flow pressure and air flow rate measurement		Note 4
Inlet Water Conditioning System	Temp control: TCS-4010	Conditioning of unit under test inlet water temperature	± 1 °C	Note 5

Notes:

1. Thermocouples are calibrated using Omega CL1500 system.
2. Each Acuvim II along with current transformer is checked against a calibrated power/current meter.
3. Flow control is checked by actual collected water weight measurement at required GPM.
4. Airflow meter is provided by Ecotope.
5. This is not used for inlet water temperature data used in calculations.
6. Checked against calibrated instrument/device.