

Advanced Water Heating Specification

Version 8.1

**A Specification for
Residential, Commercial/Multifamily, and Industrial
Water Heaters and Heating Systems**

Effective Date: July 15, 2024

Northwest Energy Efficiency Alliance
700 NE Multnomah Street, Suite 1300
Portland, Oregon 97232
p 503.688.5400
neea.org
info@neea.org



Table of Contents

1	Introduction.....	1
1.1	Purpose.....	1
1.2	Revision Notes.....	1
1.2.1	Chapter 2: Residential.....	1
1.2.2	Chapter 3: Commercial/Multifamily Water Heating Systems.....	2
1.2.3	Chapter 4: Industrial Water Heating Systems.....	2
1.3	Background.....	2
1.4	Climate Zones.....	3
1.5	Glossary.....	4
1.5.1	Residential Glossary.....	4
1.5.2	Commercial/Multifamily Glossary.....	6
2	Residential.....	12
2.1	Purpose of Residential Specification.....	12
2.2	Scope.....	12
2.3	Product Qualification.....	13
2.3.1	Qualified Products List.....	13
2.3.2	Tier Ratings.....	13
2.3.3	Testing Requirements.....	15
2.4	Residential HPWH Requirements.....	16
2.4.1	Universal.....	16
2.4.2	Energy Efficiency.....	17
2.4.3	Electric Resistance Heating.....	17
2.4.4	Demand Response Capability.....	19
2.4.5	Sound Level.....	19
2.4.6	Condensate Management.....	20
2.4.7	Airflow.....	21
2.4.8	Warranty.....	21
2.4.9	Product Documentation.....	22
2.5	Endorsements.....	23
2.5.1	Demand Response.....	23
2.5.2	Plug-In.....	23
2.5.3	Space Constrained.....	23
3	Commercial/Multifamily Water Heating Systems.....	24
3.1	Purpose of Commercial Specification.....	24
3.2	Commercial Specification Scope.....	24
3.2.1	Commercial System Definition.....	24
3.3	Commercial HPWH System Requirements.....	25
3.3.1	General Requirements.....	25
3.3.2	Standards Approval and Testing.....	25
3.3.3	CHPWH Performance Data.....	25
3.3.4	Vendor-Provided Guidance.....	26
3.3.5	Qualified Piping Configurations.....	27
3.3.6	Optional Demand Response Capability.....	31
3.4	Modeled Commercial/Multifamily System Performance.....	31
3.4.1	Commercial HPWH System Efficiency Modeling.....	31
3.4.2	Commercial HPWH System Efficiency Tiers.....	32
3.4.3	Market Delivery Methods.....	33
3.5	Resources.....	34

4	Industrial Water Heating Systems	35
4.1	Purpose of Industrial Specification	35
4.2	Industrial Specification Scope	35
4.3	Industrial System Definition	35
4.4	Industrial Applications.....	35
	Appendices.....	36
	Appendix A.1: Test and Calculation Procedures	37
A.1.1	Temperature Range Performance Testing — Integrated Units	37
	Test Setup and Procedure	37
	Calculation Method	37
A.1.2	Cool Climate Efficiency Calculation Climates (5–6)	38
	Definitions	38
	Calculation Method	38
A.1.3	OPTIONAL: Warm Climate Efficiency Calculation (1–4)	41
	Appendix A.2: Compressor Cutoff Temperature	42
	Test Setup	42
	Test Procedure	42
	Appendix A.3: High Volume Draw Test	43
	Test Setup	43
	Test Procedure	44
	Calculation and Reporting Procedure	45
	Appendix A.4: Temperature Range Performance Testing — Split Systems.....	46
	Test Setup.....	47
	Appendix B: Freeze Protection Test.....	48
	Test Setup.....	48
	Test Procedure	48
	Functionality.....	48
	Appendix C: Sound Pressure Measurement Test Method.....	49
	Test Setup.....	49
	Test Procedure	49
	Appendix D: Qualification Process.....	51
	Appendix E: Disqualification, Tier Reassignment, and Requalification Process	54
	Residential	54
	Commercial.....	55
	Appendix F: CHPWH System Performance Calculator	57
	Calculator Logic	57
	Outside Air Temperature Bins	57
	Climate Zone Weather Data	58
	Mapping Weather Data to Temperature Bins for Efficiency Calculations.....	59
	Storage and Heat Pump Outlet Water Temperatures.....	60
	Domestic Cold-Water Temperature	60
	Usage and Temperature Maintenance Loads	60
	Heat Pump Inlet Water Temperature.....	61
	Inlet Water Temperature Weighting.....	63
	Manufacturer-Reported HPWH Coefficient of Performance (COP)	64

Annual Energy Usage per Climate Zone	65
Swing Configuration - TM Heating Provided by Primary HPWH.....	65
Annual System COP per Climate Zone.....	66
COP - Lab Data Comparison.....	67
Appendix G: Low GWP Refrigerants	68
Appendix H: Commercial System COP Measurement and Verification Requirements.....	69
Methods for Installing M&V Instrumentation to Measure SysCOP	72
Boundary Method	72
Equipment Method	73
Primary Equipment Method.....	76
Equipment Method Correction Factor (Derate)	78
Required M&V Instrumentation Based on CHPWH System Configuration.....	79
Single-Pass Primary HPWH without Recirculation.....	80
Single-Pass Returned to Primary	81
Single-Pass Swing Tank	82
Single-Pass Parallel Loop Tank.....	83
Integrated HPWH without Recirculation	84
Integrated HPWH Returned to Primary.....	85
Multi-Pass Returned to Primary	86
Appendix I: Product Assessment Datasheet (PADS) Document	87
Appendix J: Commercial Integrated Performance Map Test Procedure	88
Test Conditions.....	88
First Hour Rating and Draw Pattern	89
Test Procedure	89

Table of Figures

Figure 1. 2021 US IECC Climate Zone Map by County	3
Figure 2. Single-Pass Primary HPWH System without HW Circulation	28
Figure 3. Single-Pass Returned to Primary.....	28
Figure 4. Single-Pass Swing Tank	29
Figure 5. Single-Pass Parallel Loop Tank	29
Figure 6. No Recirculation Integrated HPWH	30
Figure 7. Integrated Returned to Primary HPWH	30
Figure 8. Multi-Pass Returned to Primary.....	31
Figure 9. CCE vs. Temperature	40
Figure 10. Test Setup for Sound Pressure Measurement	50
Figure 11. Pre-AWHS Activities and AWHS Requirements	52
Figure 12. Single Pass Return to Primary Configuration	62
Figure 13. Swing Configuration.....	66
Figure 14. Coefficient of Performance (COP) Boundaries	71
Figure 15. Boundary Method – Required Instrumentation	73
Figure 16. Equipment Method – Required Instrumentation (parallel temperature maintenance configuration, excludes primary storage heat losses)	75
Figure 17. Equipment Method – Required Instrumentation (swing tank configuration).....	76
Figure 18. Primary Equipment Method – Required Instrumentation (parallel temperature maintenance configuration – includes primary storage heat losses)	77
Figure 19. Equipment Method – Required Instrumentation (swing tank configuration).....	78
Figure 20. Single-Pass Primary HPWH without Recirculation.....	80
Figure 21. Single-Pass Returned to Primary.....	81
Figure 22. Single-Pass Swing Tank	82
Figure 23. Single-Pass Parallel Loop Tank	83
Figure 24. Integrated HPWH without Recirculation	84
Figure 25. Integrated HPWH Returned to Primary	85
Figure 26. Multi-Pass HPWH Returned to Primary	86
Figure 27. Performance map for an integrated unit.....	88

Table of Tables

Table 1. Overview of Requirements by Tier.....	14
Table 2. Summary of Testing Requirements.....	15
Table 3. CHPWH System Efficiency Tiers	33
Table 4. Appendix Titles and HPWH Specification Applications.....	36
Table 5. Temperature Bins.....	38
Table 6. High Volume Draw Test Pattern.....	44
Table 7. Draft Testing Conditions for Split Systems.....	46
Table 8. Draft Temperature Bin Profile for Split-System SCOP Calculation.....	47
Table 9. Calculator Performance Map Input Table.....	57
Table 10. AWHs Hot Climate Zone.....	58
Table 11. AWHs Mild Climate Zone	58
Table 12. AWHs Cold Climate Zone	58
Table 13. AWHs Very Cold Climate Zone	58
Table 14. OAT Bins and Bounds. Min CHPWH Design Temp: -1°F	59
Table 15. OAT Bins and Bounds. Min CHPWH Design Temp: 40°F	59
Table 16. Comparison of Lab-Measured and Calculated HPWH Inlet Water Temperatures	63
Table 17. Comparison of Lab-Measured and Calculated System COP.....	67
Table 18. Equipment Method SysCOP Calculation Derate	79
Table 19. Draw Pattern for Integrated CHPWHs	89

1 Introduction

1.1 Purpose

The Northwest Energy Efficiency Alliance's (NEEA's) Advanced Water Heating Specification (AWHS) provides guidance to manufacturers and market actors interested in developing residential, commercial, multifamily, and industrial water heating products capable of providing high levels of consumer satisfaction and energy performance in a range of climates. The end goal of this effort is to ensure the introduction of new generations of heat pump water heater (HPWH) products will be successful and pave the way for HPWHs to become the standard product for all electric water heating markets.

AWHS goes beyond federal standards by addressing factors – including varying operating conditions, system COP, installation guidance, warranty requirements, controls, and user comfort – that contribute to user satisfaction and energy efficiency for a wide variety of applications. The specification uses a tier system to differentiate products by performance levels and to guide the design of future generations of HPWH products.

Energy utilities and other entities that invest in market transformation programs and/or incentives require reliable energy savings. Accordingly, this specification is also intended as a foundational document for utility program efforts that will work in partnership with manufacturers to accelerate market adoption of HPWHs for all main US and Canadian climates. Using this specification will help to improve market acceptance and ensure the expected savings materialize and persist on the grid.

This specification might also be referenced in the energy codes of states or jurisdictions to achieve higher efficiency and flexible load management in pursuit of energy and carbon reduction goals.

1.2 Revision Notes

This document succeeds the previous AWHS, Version 8.0. This version includes substantial updates to Chapters 2 and 3.

1.2.1 Chapter 2: Residential

Demand response (flexible load management) requirements will now be met through listing the product in the OpenADR Alliance's EcoPort^{CM} Certified Product Database. Previous versions of the AWHS included descriptions of demand response capabilities necessary for recognition as a demand response-capable water heater. This change allows the industry to focus its demand response and flexible load management efforts toward a single, national standard and certification process.

Split-system heat pump water heaters may now be qualified to the AWHS for operation in an interior space, exterior space, or both. Previous versions of the AWHS only allowed for split systems to be tested and rated for operation across a wide temperature range (5°F – 95°F), using the Seasonal Coefficient of Performance (SCOP) metric designed to evaluate the efficiency of outdoor installations. These products can now be rated with the Cool Climate Efficiency (CCE) metric used for indoor installations, thus accommodating a wider range of product configurations.

Plug-in water heaters will now be evaluated with the same criteria and requirements as other water heaters. Previous versions of the AWHs provided a separate set of standards for plug-ins. Products will still be recognized for meeting the AWHs definition of a “plug-in” product.

Additionally, the formatting and language in this version of the AWHs residential chapter have been significantly changed to improve clarity and usability.

1.2.2 Chapter 3: Commercial/Multifamily Water Heating Systems

AWHS v8.1 streamlines listing of commercial HPWHs (CHPWHs), aligns with Regional Technical Forum (RTF) requests, and creates a pathway for integrated CHPWHs.

This version now includes descriptions of three market delivery methods for CHPWHs that utility programs can use to specify performance validation requirements and/or to limit the products on the Qualified Products List (QPL) that can receive incentives. V8.1 includes an updated CHPWH Product Assessment Datasheet (PADS) with NEEA-approved System COP (SysCOP) calculation.

In establishing a pathway for listing integrated CHPWHs on the commercial QPL, the performance test methodologies currently under development will produce a SysCOP calculation that will facilitate listing of integrated CHPWHs in the appropriate QPL tier. Such units will use the same PADS to list but will be listed separately from split-system CHPWHs.

1.2.3 Chapter 4: Industrial Water Heating Systems

This version of the AWHs does not include specifications for industrial systems. Content for the industrial chapter remains under discussion and will be included in a future AWHs version.

1.3 Background

In the early 1980s, electric utilities in colder portions of North America requested that manufacturers introduce heat pump technology into the domestic water heating market (mostly in the residential market). HPWH programs have subsequently spanned multiple generations of technology and produced detailed measurements of technical performance and consumer acceptance. The experience gained from these programs yields definitive direction about key consumer needs as well as important technical and reliability criteria for proper application of this technology throughout a range of climates.

In 2008 the ENERGY STAR® program released its first specification for residential HPWHs. The program requirements cover important characteristics (efficiency, capacity, longevity, and electrical safety), but they proved insufficient for describing a product that could be successfully implemented across the North American market for customer acceptance. Further, ENERGY STAR does not include system-level energy efficiency standards for large-scale, central HPWH systems. AWHs adds to the ENERGY STAR program by addressing critical performance and comfort factors, as well as providing standards for system-level performance.

The earliest versions of AWHs focused on cooler “Northern” climates but subsequent versions have evolved to apply to all North American climates. By prioritizing heat pump use over resistance elements, additional performance-related functionality, and user satisfaction, this specification and related testing methodologies produce high efficiency water heating in all climates and in multiple configurations and building types.

As this latest AWHs v8.1 again demonstrates: AWHs has evolved, and will continue to evolve, along with changes to federal standards, technological advances, and market priorities.

1.4 Climate Zones

This specification is intended to ensure high performance in all main North American climates with a special focus on climates with 4,000 or more heating degree days and average air temperatures below 60°F. AWHs references climates by the zones developed by the International Energy Conservation Code (IECC).¹

Figure 1. 2021 US IECC Climate Zone Map by County

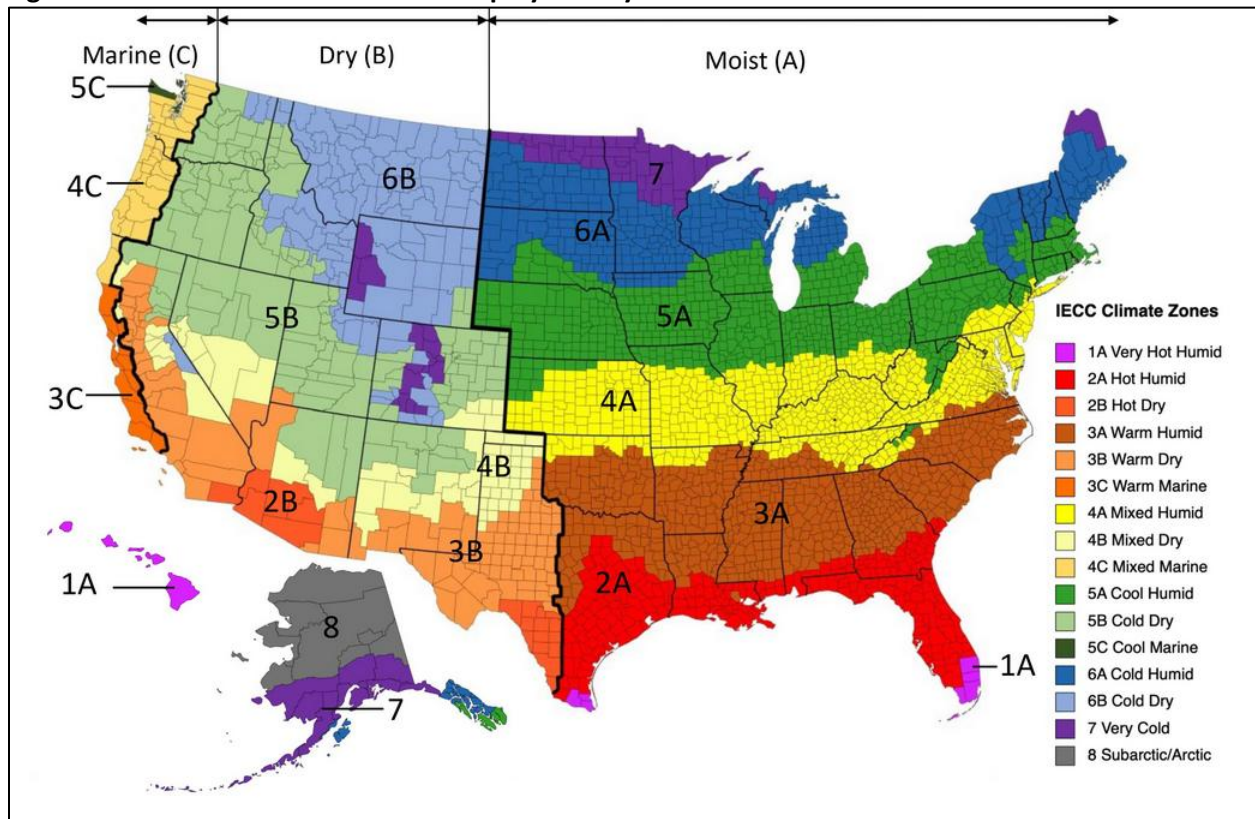



Source: https://basc.pnnl.gov/sites/default/files/images/FinalMap2021IECC_0.jpg

¹ <https://codes.iccsafe.org/content/IECC2021P1/chapter-3-ce-general-requirements>

1.5 Glossary

1.5.1 Residential Glossary

Definitions provided under this heading apply to Chapter 2 of this specification.

ambient temperature	the temperature of the air in the space surrounding the heat pump unit that is drawn into the heat pump's intake.
audible alarm	a sound produced by a HPWH of at least 50 dBA when measured 1 meter from control interface. Control interface allows user to acknowledge and silence the alarm.
combination system	a mechanical system designed to perform both domestic water heating and one or more other functions, such as space cooling/heating, pool heating, etc.
control interface	the physical component of the HPWH that is the primary means by which a user selects operational settings and receives information about the HPWH's operating state. Software installed on a device not included with the product's purchase (e.g., an app for a mobile device) is not the <i>control interface</i> .
Cool Climate Efficiency (CCE)	an energy efficiency metric developed by NEEA for air-source heat pump water heaters installed in interior spaces. CCE is defined by Appendix A.1.2 of this specification.
default mode	the operating mode used in DOE testing as described in <i>10 CFR Appendix E to Subpart B of Part 430 at Section 5: Test Procedures</i> .
DOE testing	tests performed according to the procedures described in <i>10 CFR Appendix E to Subpart B of Part 430</i> ; including FHR and UEF tests.
electronic notification	indication of a fault condition sent to the user via email, text message, app notification, or similar.
 ER heating	the process of generating heat, or the heat generated, by means of electric resistance.
fault condition	a state that prohibits the proper function of a HPWH and which requires maintenance or repair to clear. Examples of fault conditions include condensate drain blockage, refrigerant pressure problems, or insufficient airflow. <i>Fault condition</i> is exclusive of <i>normal disruption</i> .
FHR rating	the certified result of a HPWH's First Hour Rating (FHR) test as published in the <i>AHRI Directory of Certified Product Performance</i> , the <i>Product Finder</i> on the ENERGY STAR website, the <i>DOE CCMS eeCompass</i> database, or other equivalent reference publication.
FHR test	test performed according to the procedures described in <i>10 CFR Appendix E to Subpart B of Part 430, 5.3.3 First-Hour Rating Test</i> .
heat pump unit	the component of a HPWH that contains the evaporator and all moving parts. For an integrated HPWH, this term refers to the integrated unit, i.e., the entire product.
 indoor heat pump	a heat pump unit designed for installation inside a habitable structure. This term is not exclusive of <i>outdoor heat pump</i> .
installer manual	documentation published by the product's manufacturer that provides instruction for the product's installation. Term includes documentation intended for either consumer or professional installer use. <i>Installer manual</i> may also be the <i>user manual</i> .

instantaneous	describes a water heater that contains no more than one gallon of water per 4,000 Btu per hour of input.
integrated	describes a water heater that contains all heating and storage components, including heat pump, electric resistance elements, and water tank; in a single unit that may be installed with or without a mixing valve and recirculation pump. <i>Integrated</i> is exclusive of <i>split system</i> .
normal disruption	a state that temporarily prohibits the compressor's ability to operate but does not require any attention from the user to resolve and is within the expected performance of the product. Examples of normal disruptions include ambient temperatures outside of the <i>operating range</i> and defrosting processes. <i>Normal disruption</i> is exclusive of <i>fault condition</i> .
operating mode	a user-selectable option that alters the way in which the HPWH uses or restricts its heating components (heat pump and ER elements). <i>Operating mode</i> can be independent of set point selections. One <i>operating mode</i> is assumed to be less energy efficient than another if it is likely to use a greater amount of ER heating under normal operating and use conditions.
operating range	the set of conditions within which the heat pump of a HPWH is expected to operate, specifically the range of ambient temperatures.
 outdoor heat pump	a heat pump unit designed for installation outside a structure's thermal barrier and in any climate, exposed to environmental elements. This term is not exclusive of <i>indoor heat pump</i> .
product	a heat pump water heater meeting the scope of this specification. In the case of a split-system HPWH in which the heat pump unit and water storage unit are not sold as a unit, <i>product</i> refers to the specific heat pump unit-water storage unit combination that underwent DOE testing
Seasonal Coefficient of Performance (SCOP)	an energy efficiency metric developed by NEEA for air-source heat pump water heaters installed in exterior spaces. SCOP is defined by Appendix A.4 of this specification.
UEF rating	the certified result of a HPWH's <i>Uniform Energy Factor (UEF) test</i> as published in the <i>AHRI Directory of Certified Product Performance</i> , the <i>Product Finder</i> on the ENERGY STAR website, the <i>DOE CCMS eeCompass</i> database, or other equivalent reference publication.
UEF test	test performed according to the procedures described in 10 CFR Appendix E to Subpart B of Part 430, 5.4 24-Hour Simulated-Use Test.
user manual	documentation published by the product's manufacturer that provides instructions for the owner and the users of a HPWH on its proper operation and routine maintenance requirements. <i>User manual</i> may also be the <i>installer manual</i> .
visual alarm	an indication of a fault condition, appears on the control interface and provides clear direction to the user on how to clear the fault condition.

1.5.2 Commercial/Multifamily Glossary

Definitions provided under this heading apply to Chapter 3 of this specification.

auxiliary or backup heating

A supplementary water heating system that provides continuation of hot water delivery in the event the HPWH is not functioning or is unable to supply sufficient hot water to meet current needs.

aquastat fraction

The point in the entire primary storage volume where the temperature trigger (aquastat) for cycling on the HPWH is placed. The default is to place this aquastat so that 40% of the primary storage (typically defined by the manufacturer or engineer) is used when the heat pump equipment is triggered to cycle on. This is controlled by the location of the aquastat port on the storage equipment that is being purchased.

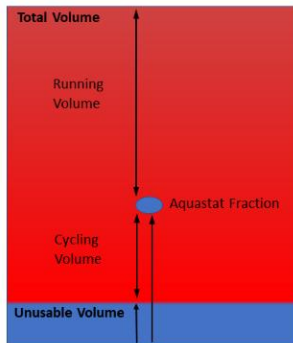

climate zones

The eight US climate zones are based on temperature, precipitation, and heating and cooling degree days. The eight zones are: hot-humid, hot-dry, mixed-dry, mixed-humid, marine, cold, very cold, and subarctic. AWHs references climates by the zones developed by the International Energy Conservation Code (IECC).

Figure 1. 2021 US IECC Climate Zone Map by County

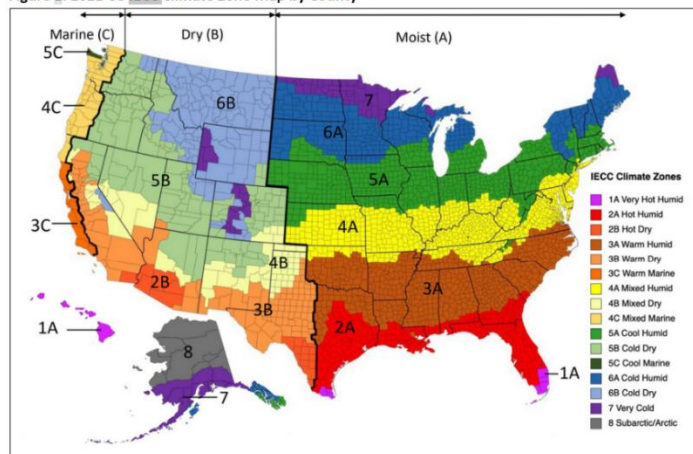

Source: https://bascc.pnnl.gov/sites/default/files/images/FinalMap2021IECC_0.jpg

**custom
engineered
system**

A system that typically requires engineering design and support. It represents systems for which a single seller, distributor, or company supplies only the HPWH components without design specifications for the entire commercial HPWH system. In Custom Engineered Systems, the project-specific Engineer of Record selects and specifies the components that make a commercial HPWH system, including the storage tank(s), temperature maintenance system, circulation pump(s), mixing valve, auxiliary heaters, and storage tank controls, which are then typically purchased and installed by a contractor.

**design cold
water
temperature**

This is the coldest water temperature supplied by incoming city water. Increasing this value means the HPWH has a lower temperature lift to the hot water supply temperature, and the required heating capacity will decrease.

EcoPort^{CM}

Branded name for CTA-2045

Ecosizer

The Ecosizer² is a free tool for sizing CHPWHs in multifamily buildings. The tool is designed to support the building industry to adopt CHPWHs to improve energy efficiency and reduce greenhouse gas emissions. The Ecosizer is also intended to provide educational information on CHPWH system designs to other stakeholders such as energy efficiency and building decarbonization advocates, program administrators and implementers, building science researchers, manufacturers, and policymakers.

**equipment
coefficient of
performance
(ECOP)**

The efficiency of each separate piece of equipment. For HPWH equipment, the ECOP varies with air and water temperatures.

**fully
packaged/skid-
mounted**

An all-in-one package that can be shipped and installed as a complete solution to serve a specific number of occupants and/or dwelling units. At minimum, this includes the following components: the primary HPWH(s), the primary storage tank(s), the temperature maintenance system (when present), all ancillary piping components, and a control system. The systems are designed, configured, and built up as a complete functional domestic hot water system and can be shipped in a maximum of three pieces for field connection.

² <https://ecosizer.ecotope.com/sizer/>

**fully specified
built-up system**

A fully specified package of parts, pieces, controls, and design assistance provided by a single seller, distributor, or company that comprises everything needed for a commercial HPWH system (“parts and smarts”). It includes the heat pump and specifications for the heat pump system, allowable piping configuration, schematics, sequences of operations, and at a minimum, guideline specifications for all major commercial HPWH system components that comprise a fully functional system (HPWH(s), storage tank(s) temperature maintenance system, circulation pump(s), mixing valve, auxiliary heaters, and controls). This follows the Variable Refrigerant Flow (VRF) model in which everything needed for a complex field-installed system is provided by a single manufacturer and designed to work together as a system.

**hot water
recirculation
loop**

This term represents the portion of the hot water distribution system where the water is circulated at a low constant or nearly constant flow rate to keep the water in the distribution piping near the end use fixtures at or near the delivery water temperature (typically 120°F).

**hot water
storage
temperature**

The set point temperature of the primary HPWH, or the hottest temperature provided by the primary heat pump equipment.

load shift

The ability of the HPWH to turn off or minimize use to avoid electricity draw and reduce peak loading on utilities. The load shift function allows the user to block out part of the day when the HPWHs will not run. The storage volume and heating capacity necessary to meet the load is sized similarly as in the primary system, but accounts for period(s) during which the HPWHs will not run as requested by utility signals. This necessarily means that the storage volume must be higher so that the volume in the primary storage can provide the building occupants with hot water for the period when the heat pumps are prevented from running and can meet any peaks after the end of the load shift period(s).

**major
components**

Major components of a CHPWH system include the primary heating system: heat pump water heater(s). Primary storage: hot water storage tank(s), temperature maintenance system (where applicable): temperature maintenance storage tank(s), temperature maintenance heat source(s), hot water circulation pump, and mixing valve, controls and sensors: either internal to the heating equipment or stand-alone system controller.

**multi-pass heat
pump water
heater**

A multi-pass heat pump water heater does not target a specific outlet temperature, but adds heat to the storage tank in steps until the tank setpoint is reached. Multi-pass heat pump water heaters may use constant speed pumps to provide flow through the condenser, and whatever temperature lift can be achieved at the flow provided is achieved. Water is pulled from near the bottom of the storage tank and returned to an inlet just above the outlet, similar to gas boiler piping. Multi-pass heat pump water heaters are less stratified and provide less load shift potential than single-pass HPWHs.

number of apartments	Total number of apartment units in the building. An increase in the number of apartments in a building will result in increased temperature maintenance losses for a given recirculation loop heat loss.
parallel temperature maintenance tank or parallel loop tank	Single-pass HPWHs are most efficient when heating cool city water to hot storage temperatures, whereas multi-pass equipment can still operate efficiently when incoming water temperatures are around 120°F. A parallel loop configuration is one strategy used to isolate the temperature maintenance task from the task of heating the primary storage. A parallel loop tank is an electric resistance element or a multi-pass heat pump that is piped in parallel with the primary system, specifically to handle the temperature maintenance load.
parallel primary storage tank configuration	A storage tank configuration in which multiple tanks are piped in parallel to achieve a larger storage volume. The parallel primary storage tank configuration relies on equal flow through the parallel piping circuits for system balancing.
primary heating system — no recirculation	A system with equipment that operates only as a primary heating device for heating the cool water from the city or main to the hot water storage tank set point.
primary coefficient of performance (PCOP)	PCOP represents the efficiency of the primary heating equipment. It incorporates losses from storage and energy use of any auxiliary or backup equipment. It is generally described as an average annual value.
recirculation loop flow rate	The rate at which a recirculation pump moves hot water through the distribution loop in gallons per minute. Section 2.2 of this specification defines the Residential scope.
recirculation loop heat loss	<p>Losses associated with the recirculation loop expressed in Watts/apartment unit. A value of 60 Watts/apartment can be used to compare systems. Ideally, building and plumbing design will minimize this load. Increasing the recirculation loop heat loss rate will increase the temperature maintenance load expected and thus energy used to supply hot water.</p> <p>The research to date indicates 60 W/apt is a reasonable value to use for new construction energy usage calculations, but the range of recirculation loss load varies greatly building by building.</p>
recirculation loop return temperature	The temperature of hot water when it returns to the temperature maintenance tank. This variable is used along with the recirculation loop flow rate to calculate the recirculation loop heat loss rate.
series primary storage tank configuration	A storage tank configuration in which multiple tanks are piped in series to achieve a larger storage volume. The hot outlet of the first tank is piped to the bottom of the second tank, and so forth.

**single-pass heat
pump water
heater**

A single-pass heat pump water heater modulates flow to control its outlet water temperature to the setpoint which is required at the top of the primary storage tanks. Water is pulled from near the bottom of the primary storage tanks, heated by the HPWH in a single-pass, and returned to the top of the storage tanks, increasing stratification, load shift potential, and in many cases increasing efficiency above what can be achieved by multi-pass HPWHs.

**split-system
HPWH**

A split-system HPWH is a heat pump water heater composed of (at least) two components. The evaporator, and often the compressor, expansion valve, and condenser, are detached from the thermal storage. The detached equipment is often located in a remote location, such as outdoors, so that heat is absorbed from a different location from the closed environment in which it is stored. Split systems may transfer heat using water, glycol mix, refrigerant, or other medium, piped between the remote equipment and the thermal storage. In some cases, a heat exchanger is also included between the outdoor equipment and the thermal storage. *Split-system HPWH* is exclusive of *integrated*.

**storage
efficiency**

The fraction of the primary storage volume that is filled with hot water at the storage temperature. The storage efficiency is used to check that the primary storage volume between the aquastat and the bottom of the effective storage volume is large enough that the primary HPWHs can cycle for at least 10 minutes without any hot water draws. Having a cycling volume greater than this minimum helps build a robust CHPWH system and adds some safety in the storage volume.

**supply water
temperature**

The water temperature supplied to the building occupants from the hot water system. The default is set to 120°F, an industry standard. If aligning sizing efforts with CA Title 24 software, the temperature should be increased to 125°F.

Increasing the supply water temperature raises the reference temperature for the building occupants' use. This will increase the storage volume as the hot water stored has less potential energy over the supply water temperature.

swing tank

A swing tank design is a proven technique to use the primary heat pumps to support the temperature maintenance load, while keeping the heat pump equipment isolated from the warm water returning from the recirculation loop. This design strategy is best suited for buildings with low temperature maintenance loop losses (< 60W/apt) and relies on increased storage volume (with tanks piped in series) to ensure storage stratification. Swing tank systems have an electric resistance element in the temperature maintenance tank as a backup safety factor. Sizing a swing tank system also means increasing the heating capacity and storage volume of the primary system. The temperature maintenance storage volume for the swing tank can be small.

**system
coefficient of
performance
(SysCOP)**

The efficiency of the entire domestic hot water system. It includes all the heat energy put into the system to heat and maintain hot water over all the electrical energy used to heat and maintain hot water. SysCOP is typically described as an average annual value that accounts for climate conditions and entering and leaving water conditions.

**temperature
maintenance
coefficient of
performance
(TMCOP)**

The efficiency of the temperature maintenance system or the system that maintains the temperature of water in the hot water distribution piping at or near the supply water temperature. It incorporates losses from storage and energy use of any auxiliary or backup equipment.

**temperature
maintenance
system**

A system that maintains the temperature of water in the hot water distribution piping at or near the supply water temperature. Common practice in the industry is to circulate the hot water in the distribution piping at a rate that keeps the water near the supply water temperature of around 120°F. This term also includes heat trace or heat tape systems that utilize an electric resistance element attached to the HW distribution piping to maintain the water temperature near the supply water temperature.

**temperature
maintenance
system safety
factor**

The safety factor of the temperature maintenance heater over the temperature maintenance load. A higher safety factor will increase the output of the temperature maintenance heater. If the safety factor were set to 1, the temperature maintenance heater and the temperature maintenance load would be in perfect balance.

**temperature
maintenance
turn-on**

This term, the temperature maintenance set point, and the one cycle off time are critical to sizing a multi-pass HPWH system. The temperature maintenance turn-on is the temperature of the water that will trigger the temperature maintenance to begin a heating cycle—in other words, the lowest temperature to which the temperature maintenance tank should be allowed to drop. This cannot be less than the supply temperature.

2 Residential

2.1 Purpose of Residential Specification

This Residential chapter of the Advanced Water Heating Specification describes consumer water heater characteristics that contribute to:

- Energy efficiency, energy cost savings, and load shifting capabilities
- User comfort and satisfaction
- Proper installation, and features that address specific market needs
- Improved public perception of heat pump water heaters

2.2 Scope

This specification only applies to products that meet all of the following:

- Electric fuel source only
- Employs an air-source heat pump
- Has a storage capacity of 119 gallons or less
- Has a maximum current of 24 Amps at 250 Volts (6kW).
- Meets the definition of a “water heater” in the Code of Federal Regulations 10 CFR 430.2
- Is of a configuration that can be tested under U.S. Department of Energy (DOE) testing procedures to produce both a First Hour Rating (FHR) and a Uniform Energy Factor (UEF) rating

The following products are out of scope for this specification:

- Combination systems that cannot operate solely as a water heater
- Products that employ a heating technology other than a heat pump or electric resistance
- Instantaneous water heaters
- Gas-fueled heat pump water heaters
See [Advanced Water Heating Specification for Gas-Fueled Residential Storage Water Heaters](https://neea.org/img/documents/Natural-Gas-Advanced-Water-Heating-Specification.pdf)
<https://neea.org/img/documents/Natural-Gas-Advanced-Water-Heating-Specification.pdf>

2.3 Product Qualification

2.3.1 Qualified Products List

Products that meet the requirements of the AWHS may be included on the Residential HPWH Qualified Products List (QPL). The QPL is a public document published by NEEA that recognizes HPWHs for design and performance characteristics. The QPL is referenced by organizations, both public and private, throughout the US, and is used by some as a basis for issuing consumer rebates, tax credits, and other incentives.

The Residential Heat Pump Water Heater Qualified Products List can be found at www.neea.org/resources/residential-hpwh-qualified-products-list.









To submit a product for qualification to AWHS: See **Appendix D: Qualification Process**.

2.3.2 Tier Ratings

Products qualified to the AWHS are assigned tier ratings based on their efficiency, features, and manufacturer support.

Requirements for each tier are described in Section 2.4. The following table provides an overview of those requirements. The table is intended only as a summary; qualification to AWHS is based solely on the requirements as described in Section 2.4.





Table 1. Overview of Requirements by Tier

	Tier 1	Tier 2	Tier 3	Tier 4	Tier 5	
Universal See Section 2.4.1	Certified by UL, ETL, CSA or similar					
	ENERGY STAR certified					
		Passes Freeze Protection test				
	High Volume Draw test results					
Energy Efficiency See Section 2.4.2		CCE ≥ 2.0	CCE ≥ 2.3	CCE ≥ 2.6	CCE ≥ 3.0	CCE ≥ 3.5
		SCOP ≥ 2.1	SCOP ≥ 2.4	SCOP ≥ 2.7	SCOP ≥ 3.1	SCOP ≥ 3.6
ER Heating See Section 2.4.3		In FHR test, at least 66% of tank volume drawn before ER element engages			No ER above -5° F ambient temperature	
		ER limited to top half of tank				
		Selection of a less efficient operating mode expires within 72 hrs				
		After a power failure, product automatically resumes in default mode or most recently selected mode				
		Controls indicate when heat pump is disabled due to a normal disruption; heat pump resumes when disruption ends				
		If heat pump is disabled due to a fault condition, unit produces a visual alarm and either an audible alarm or electronic notification				
		Product ships in default mode				
Demand Response Capability See Section 2.4.4		Bears Demand Response certification				
Sound Level See Section 2.4.5		< 65 dB(A)	< 60 dB(A)	< 55 dB(A)	< 50 dB(A)	
		< 65 dB(A)	< 60 dB(A)	< 50 dB(A)		
Condensate Management See Section 2.4.6		Product includes standard plumbing connection for drain line				
		Condensate removal system does not require regular maintenance, and allows clearance of blockages with normal household tools				
		Condensate blockage disables compressor				
Airflow See Section 2.4.7		Any filter is washable or a standard product				
		Controls indicate when filter needs maintenance				
		Heat pump unit can be ducted and instructions for proper ducting are provided				
Warranty See Section 2.4.8		Minimum 10 years parts, 1 year labor				
Product Documentation See Section 2.4.9		Airflow clearance				
		Installation examples				
		Freeze protection				
		Condensate management				
		Warranty sticker				
		Ducting				

2.3.3 Testing Requirements

Laboratory test results are required when submitting a product for qualification to AWHs. The specific tests required depend on the product design.

Table 2. Summary of Testing Requirements

Test	Required for	Reference
Compressor Cutoff	All products	Appendix A.2. Compressor Cutoff Temperature
COP_A, COP_B, COP_D	 Products with outdoor heat pump*	Appendix A.4. Temperature Range Performance Testing—Split Systems
E₅₀	 Products with indoor heat pump*	Appendix A.1.1. Temperature Range Performance Testing—Integrated Units
E₉₅	<i>Optional test for products with indoor heat pump</i>	<i>Appendix A.1.1. Temperature Range Performance Testing—Integrated Units,</i>
FHR	All products	Refer to DOE testing procedures
Freeze Protection	 Products designed to circulate water outside the thermal boundary of a conditioned structure	Appendix B. Freeze Protection Test
High Volume Draw	 Tier 1-4 products with ER heating	Appendix A.3. High Volume Draw Test
Sound Pressure Level	All products	Appendix C. Sound Pressure Measurement Test Method
UEF	All products	Refer to DOE testing procedures

2.3.3.1 Split System Testing

Split system products can be qualified only if all components are included in the product, or as a combination of a specified heat pump unit and specified water storage unit. Because split-system HPWHs composed of the same heat pump unit but different water storage units can produce different results, all components must be part of the qualified product description and the product must be tested in that configuration.

2.3.3.2 Combination System Testing

Combination system products can be qualified only if they are capable of operating in a domestic water heating-only configuration and mode, and undergo testing in this configuration and mode.

* Current versions of the temperature range performance test procedures assume that all split systems are designed for the heat pump unit to be located outdoors only and that all integrated products are designed for indoor installation only. Procedures will be revised in a future revision of the specification. In the meantime, manufacturers with product designs that are not accommodated by the current test procedures should contact HPWH_Assessments@neea.org for direction on testing.

2.4 Residential HPWH Requirements

2.4.1 Universal

Items described as universal requirements are required of all products qualified to the AWHs. These requirements are equal for all tier ratings.

2.4.1.1 Standards

Product is approved to the applicable standard by one or more of the following agencies:

- Underwriters Laboratories (UL)
- Electrical Testing Laboratories (ETL)
- CSA International (CSA)
- An equivalent third-party agency

Product can be installed in the US or Canada.

2.4.1.2 ENERGY STAR®

Product is certified to the version of the *ENERGY STAR Program Requirements for Residential Water Heaters* in effect at the time of the product's submission to NEEA for qualification to AWHs.

Referencing www.energystar.gov/products/res_water_heaters_partners, NEEA verifies certification by confirming the product is included in the Product Finder on the ENERGY STAR website:

<http://www.energystar.gov/productfinder/product/certified-water-heaters>.

2.4.1.3 Freeze Protection



Applies only to products designed to circulate water outside the thermal boundary of a conditioned structure

Product passes Freeze Protection Test.

See [Appendix B: Freeze Protection Test](#)

2.4.1.4 Shipments Data

Manufacturer may voluntarily provide NEEA with numbers of consumer heat pump water heaters shipped to or sold in Idaho, Montana, Oregon, or Washington. All data will be held in confidence. Data may be required in future versions of this specification.

2.4.1.5 High Volume Draw Test



Applies only to products with ER heating rated to Tier 1, 2, 3, or 4

Manufacturer provides NEEA with results of product's performance in the High Volume Draw Test.

See [Appendix A.3: High Volume Draw Test](#)

2.4.1.6 Product Documentation

See Section 2.4.9—Product Documentation for content requirements.

2.4.2 Energy Efficiency

2.4.2.1 Indoor Heat Pumps – Cool Climate Efficiency (CCE)



Applies only to indoor heat pump products

Tier 1: CCE \geq 2.0

Tier 2: CCE \geq 2.3

Tier 3: CCE \geq 2.6

Tier 4: CCE \geq 3.0

Tier 5: CCE \geq 3.5

See [Appendix A.1, Sections A.1.1 Temperature Range Performance Testing – Integrated Units](#) and [A.1.2 Cool Climate Efficiency Calculation Climates \(5–6\)](#)

2.4.2.2 Outdoor Heat Pumps – Seasonal Coefficient of Performance (SCOP)



Applies only to outdoor heat pump products

Tier 1: SCOP \geq 2.1

Tier 2: SCOP \geq 2.4

Tier 3: SCOP \geq 2.7

Tier 4: SCOP \geq 3.1

Tier 5: SCOP \geq 3.6

See [Appendix A.4: Temperature Range Performance Testing – Split Systems](#)

2.4.3 Electric Resistance Heating



Applies only to products with ER heating

2.4.3.1 Product Design

Tier 1: n/a

Tier 2: During the FHR test, at least 66% of product's rated storage volume is withdrawn before ER engages

Tier 3: all above

Tier 4: Product does not use ER heating in the lower half of the storage tank's volume when within the heat pump's operating range, + all above

Tier 5: Product does not use ER heating in default mode unless ambient temperature is lower than -5°F

2.4.3.2 *Operating Mode Selection*

Tier 1: n/a

Tier 2: If user selects an operating mode less efficient than the default mode, that selection expires after 72 hours or less. Upon expiration, the product reverts to either the default mode or the operating mode that was active prior to the user selection. The product does not revert to an operating mode that uses only ER heating.

If user selects an operating mode that disables the heat pump (i.e., ER heating only), the control interface indicates that the heat pump is disabled.

Tier 3: When first energized, product operates in default mode without selection required by user/installer, + all above

Tier 4: all above

Tier 5: all above

2.4.3.3 *Power Failure*

Upon restoration of power after a power failure:

Tier 1: n/a

Tier 2: Product automatically resumes operation in either the default mode or the most recently selected operating mode.

Tier 3: all above

Tier 4: all above

Tier 5: all above

2.4.3.4 *Normal Disruption to Heat Pump Operation*

When the heat pump is disabled due to a normal disruption:

Tier 1: n/a

Tier 2: The control interface indicates that the heat pump is not operating. Upon the end of the normal disruption, product resumes operating the heat pump.

Tier 3: all above

Tier 4: all above

Tier 5: all above

2.4.3.5 *Fault Condition Alarms*

When the heat pump is disabled due to a fault condition:

- Tier 1: n/a
- Tier 2: Product produces
 - 1) a visual alarm and
 - 2) an audible alarm, an electronic notification, or both
- Tier 3: all above
- Tier 4: all above
- Tier 5: all above

2.4.4 *Demand Response Capability*

- Tier 1: n/a
- Tier 2: n/a
- Tier 3: [Bears](#) the Demand Response certification described in Section 2.5
- Tier 4: all above
- Tier 5: all above

2.4.5 *Sound Level*

2.4.5.1 *Indoor Heat Pumps*



Applies only to indoor heat pump products

Sound pressure level of heat pump unit as measured according to the Appendix C. Sound Pressure Test Method is:

- Tier 1: < 65 dB(A)
- Tier 2: < 60 dB(A)
- Tier 3: < 55 dB(A)
- Tier 4: < 50 dB(A)
- Tier 5: < 50 dB(A)

2.4.5.2 Outdoor Heat Pumps



Applies only to outdoor heat pump products

Sound pressure level of heat pump unit as measured according to the Appendix C. Sound Pressure Test Method is:

- Tier 1: < 65 dB(A)
- Tier 2: < 60 dB(A)
- Tier 3: < 50 dB(A)
- Tier 4: < 50 dB(A)
- Tier 5: < 50 dB(A)

2.4.6 Condensate Management

Tier 1: n/a

Tier 2: Product includes a standard connection for the attachment of a condensate drainage line of proper size to function for the life of the product under normal use.

Components of the condensate collection and drain system that are part of the product itself do not require regular maintenance or interaction by the user for the life of the product.

Condensate management design allows user to clear blockages with normal household tools.



Applies only to indoor heat pump products: Product automatically disables compressor in the event of condensate removal system blockage.

See [Section 2.4.9 — Product Documentation](#) for condensate-related documentation requirements.

- Tier 3: all above
- Tier 4: all above
- Tier 5: all above

2.4.7 Airflow

Tier 1: n/a

Tier 2: n/a

Tier 3: **For products with air filters:**

Filter(s) is either 1) permanent washable media or 2) replaceable, standard filters in shapes and forms available at a typical hardware store.

Product directs user, through the control interface and/or an electronic notification and when appropriate, to wash/replace filter to prevent compromised heat pump performance, as defined by manufacturer.

Ducting:



Applies only to indoor heat pump products

Heat pump unit allows for the fitting of common ducting products either directly to the unit or with the use of specified add-on products readily available to consumers.

Heat pump functions both with and without ducting attached.

See [Section 2.4.9—Product Documentation](#) for ducting-related documentation requirements.

Tier 4: all above

Tier 5: all above

2.4.8 Warranty

Tier 1: n/a

Tier 2: Product carries a warranty of at least 10 years for all system parts and at least 1 year from date of installation for labor.

See [Section 2.4.9—Product Documentation](#) for warranty-related documentation requirements.

Tier 3: all above

Tier 4: all above

Tier 5: all above

2.4.9 Product Documentation

Tier 1: **Airflow clearance:** Installer manual includes clearance requirements for proper airflow to and from evaporator.

Installation examples: Installer manual includes examples of possible configurations or installation scenarios and instructions for how to install the product properly in those configurations/scenarios.

Freeze protection:



If product is designed to circulate water outside the thermal boundary of a conditioned structure: Installer manual includes instruction for preventing freezing in cold temperatures without power.

Tier 2: **Condensate:** Installer manual includes:

- Specifications for condensate drain line including: pipe/tubing diameter, length, turns, slope, and termination;
- Instructions for both gravity drains and situations where gravity drains are not possible; and
- Language highlighting the importance of correct condensate line installation practices and adherence to applicable plumbing codes.

Warranty sticker: A toll-free number is clearly visible on the primary indoor component of the product and provides callers with

- Warranty service,
- Replacement filters or other maintenance items, and
- Technical support.

and all above

Tier 3: **Ducting:**



For indoor heat pump products: Installer manual for water heater and/or installer manual for add-on ducting products includes ducting design requirements to maintain sufficient airflow to operate as a heat pump, such as maximum equivalent duct lengths for given diameters.

and all above

Tier 4: all above

Tier 5: all above

2.5 Endorsements

In addition to tier rating, products qualified to AWHs can also qualify for optional endorsements. Endorsements are included on the Qualified Products List along with other pertinent information about the product. They allow consumers to identify products with features that either go above the minimum requirements of the product's tier rating or that address specific installation challenges.

2.5.1 Demand Response

The Demand Response endorsement is required for a Tier 3 or higher rating; it is optional for Tier 1 and Tier 2.

Requirement: Product satisfies at least one of the following methods of demand response capability certification:

2.5.1.1 EcoPort^{CM}:

- Listed in the OpenADR Alliance's *EcoPort Certified Product Database*
<https://ecoport.openadr.org/>

2.5.1.2 AHRI 1430:

- Listed as compliant with standard *AHRI 1430-2022 (I-P): Demand Flexible Electric Storage Water Heaters (with Addendum 1)* in a publicly accessible list or database maintained by the Air-Conditioning, Heating, and Refrigeration Institute (AHRI)

Note: As of the date of publication of this specification, no such list or database is available. This option for satisfying demand response capability requirements is included to allow the use of such a list/database should it become available in the future.

2.5.2 Plug-In



Requirements:

- Product is able to operate on a 120 Volt / 15 Amp circuit shared with other uses
- Product includes a power cord allowing plug-in to a standard 120 Volt receptacle
- Installer manual contains necessary references to National Electrical Code (NEC) and Uniform Plumbing Code (UPC) and describes a list of approved installation locations and electrical connection scenarios

2.5.3 Space Constrained



Requirements:

- As installed, product has maximum dimensions of 24 by 26 by 72 inches, inclusive of drain pan and all plumbing connections
- Manufacturer specifies the minimum dimensions for an opening the product can be moved through

3 Commercial/Multifamily Water Heating Systems

This chapter covers the specifications for commercial water heating systems, primarily targeting multifamily water heating systems.

3.1 Purpose of Commercial Specification

The purpose of this specification is to ensure the repeatable and reliable design and installation of domestic hot water (DHW) HPWH systems, and to ensure these systems perform at the level of efficiency system designers expect. This is accomplished by creating a list of qualified HPWH products (Commercial HPWH Qualified Products List (QPL)) that designers, installers, and governing bodies can reference when designing, regulating, incentivizing, or comparing HPWH systems.

Commercial HPWH products may be listed on the commercial QPL by the manufacturer or distributor. The term “vendor” or “product vendor” is used to describe the listing entity. The commercial QPL includes approved applications where necessary because not all commercial products are suitable for all applications. NEEA, not the product vendor, is currently responsible for determining approved applications that meet the AWHS.

3.2 Commercial Specification Scope

This section of the specification addresses the performance of commercial heat pump water heater (CHPWH) systems. CHPWH systems are defined by specific product characteristics. For small integrated heat pumps that do not meet the CHPWH definition, see the Residential chapter of this document.

3.2.1 Commercial System Definition

This section of the AWHS is applicable to all commercial building types — including multifamily, food service, assembly, etc. In this specification, CHPWH systems may be defined by using the most current DOE definition, or as systems that:

1. Serve more than four dwelling units, or
2. Serve commercial loads needing more than a total of 119 gallons of storage volume, and/or more than 6 kW of input power.

These systems can be either integrated or split systems and can be configured in several ways, discussed below in Section 3.3.5.

For the purposes of this specification, the following **Major Components** are included in the commercial HPWH system:

1. Primary heating system: heat pump water heater(s)
2. Primary storage: hot water storage tank(s)
3. Temperature maintenance system (where applicable): temperature maintenance storage tank(s), temperature maintenance heat source(s), hot water circulation pump, and mixing valve
4. Controls and sensors: either internal to the heating equipment or stand-alone system controller

3.3 Commercial HPWH System Requirements

For CHPWH systems to be considered for inclusion on the Qualified Products List, HPWH product vendors must complete and submit a Product Assessment Datasheet (PADS) that outlines compliance with the requirements in this section. A completed PADS must be submitted for each product with unique performance data (see Section 3.3.3 below for performance data requirements), system configuration, and/or other changes that may influence the PADS submission. Products submitted for inclusion on the QPL must be verified to have met the requirements in Sections 3.3.1–3.3.5, below. Products that do not meet all requirements may still be listed as Tier 0 products and PADS documentation shall indicate which requirements are not met.

3.3.1 General Requirements

Products shall meet the following requirements for inclusion on the Qualified Products List:

1. CHPWH vendor shall provide a minimum one-year parts warranty on the HPWH and a five-year parts warranty on the compressor(s) that commences on the HPWH system startup date or six months after the HPWH ship date, whichever is earlier.
2. For CHPWH systems that correspond to market delivery methods of Fully Packaged Skid-Mounted System or Fully Specified Built-Up System (see Sections 3.4.3.1 and 3.4.3.2, respectively, for definitions), the vendor shall provide a minimum five-year parts warranty on all Major Components (see Section 3.2.1 for definition) and one-year labor warranty for CHPWH system troubleshooting, technical support, and parts replacement that commences on the CHPWH system startup date or six months after the CHPWH ship date, whichever is earlier. Alternatively, the vendor may provide a three-year parts warranty and a three-year labor warranty meeting the same requirements above.
3. The CHPWH system startup shall be performed by a vendor-authorized service provider.
4. The CHPWH system shall alarm if the CHPWH compressor fails to start. Alarm may be audible, text, or email.

3.3.2 Standards Approval and Testing

CHPWH systems using synthetic refrigerants shall meet UL 60335-2-40 or UL 1995 through testing by a Nationally Recognized Testing Laboratory (NRTL).³ Products using natural hydrocarbon refrigerants shall meet UL 60335-2-40, UL 1995, or have a CE listing.⁴

3.3.3 CHPWH Performance Data

Vendors are required to submit performance data for CHPWHs to be listed on the Qualified Products List (above Tier 0). For split-system CHPWHs, performance map data that includes a full range of inlet and outlet water temperatures, ambient air temperatures, and resulting input and output capacity is required for listing. Performance testing requirements for integrated CHPWHs are under review.

³ A Nationally Recognized Testing Laboratory (NRTL) is a private-sector organization that the Occupational Safety and Health Administration (OSHA) has recognized as meeting the legal requirements in 29 CFR 1910.7 to perform testing and certification of products using consensus-based test standards.

⁴ While products using natural hydrocarbon refrigerants and having a CE listing may be included on the NEEA QPL, local code officials may reject their use if they do not have a UL 60335-2-40 listing. NEEA does not assume responsibility for issues that may arise while attempting to permit designs using non-UL listed products. Project teams should verify with local Authorities Having Jurisdiction (AHJs) before attempting to install any product that lacks UL certification.

Vendors may submit product performance data collected through lab testing, field studies, or generated via simulation. However, performance data submitted via simulation or field data is subject to derate as part of the annual system coefficient of performance (SysCOP) calculation. However, if field data is collected by a third party and analyzed to the satisfaction of NEEA, the derate may be removed. (See Section 3.4.1 for discussion of SysCOP methodologies.) Vendors are encouraged to submit performance data tested using the test setup, tolerances, and procedure outlined in ANSI/ASHRAE Standard 118.1-2012, Method of Testing for Rating Commercial Gas, Electric, and Oil Service Water-Heating Equipment. Performance data will be utilized per Section 3.4 to model HPWH system efficiency. Appendix D describes the qualification process and provides details on submitting data.

3.3.4 Vendor-Provided Guidance

Manufacturers shall provide access to detailed CHPWH system design and installation guidance that includes the following items. Availability of this information shall be subject to audit.

1. **Summary of HPWH System Operation:** Description of CHPWH system including piping configuration and all required system components. System configuration shall be one of the listed Qualified Piping Configurations per AWH Section 3.3.5. Include discussion of approach to defrost.
2. **Detailed Piping Schematics:** Piping schematic shows a complete system and how the system is connected to the building — entering city water, hot water supply, and hot water return. Schematic shall include one of the Qualified Piping Configurations per AWH Section 3.3.5 and shall identify location of all required system components for operation and maintenance (as applicable) including valves, strainers, mixing valve(s), storage tank(s), swing tank(s), pumps, and control instrumentation.
3. **Component Performance Specifications:** Detailed performance specification and shop drawings for all basis-of-design for all major components (see Section 3.2.1 for definition).
4. **Requirements for Ancillary HPWH System Components:** When required, ancillary system components (such as isolation valves, check valves, balancing valves, wye strainers, unions, T&P valves, and air vents) are specifically identified, including sizing, and performance requirements. The required location in the system is identified through the detailed piping schematic described above in **2. Detailed Piping Schematics**.
5. **CHPWH Output Capacity and Storage Capacity Guidelines:** Detailed guidance on CHPWH capacity sizing and hot water storage sizing based on design loads and load shift requirements (if applicable). The equipment provider has available a sizing tool or refers customers to an applicable third-party tool.
6. **Potable Water Quality Requirements:** Minimum potable water quality requirements.
7. **Potable Water Pressure Requirements:** Minimum and maximum water pressures allowable for all major components.

8. **Water Flow Requirements:** Maximum design water flow through HPWH (using maximum operating air temperature and minimum temperature rise through HPWH).
9. **Air Source Design Guidelines:** Design considerations such as 1) minimum airflow requirements, 2) external static pressure available (if applicable), 3) orientation and placement of outdoor unit (best practices for), and 4) ductwork connection details (if applicable).
For systems where the compressor equipment is installed indoors — including integrated units — buffer space requirement (cubic footage and configuration, i.e., horizontal and/or vertical) shall include 1) minimum volume and maximum space height, 2) minimum required internal gains, and 3) minimum required airflow.
10. **Electrical Specifications:** All available voltage and phases, full load amps (FLA), minimum circuit ampacity (MCA), maximum overcurrent protection (MOP).
11. **Sound Levels and Testing:** Data on sound levels and sound testing method.
12. **Installation Specifications and Requirements:** Mounting details, clearance requirements, connection details, and any other information needed to physically install the CHPWH.
13. **Maintenance Requirements:** Maintenance checklist including detailed description of task and recommended cadence for performing tasks. The maintenance checklist must include recommended maintenance for the entire system, not just the CHPWH — except for listings under Market Delivery Method C, which can just provide maintenance tasks for the CHPWH.
14. **Equipment Manuals and Warranty:** Equipment operating manuals and warranty documentation. To include detailed startup procedures for both the CHPWH equipment and CHPWH system.
15. **Sequence of Operation:** Includes specific set point temperatures (on, off, leaving water temp) and sensor callouts that align with the **2. Detailed Piping Schematics**. When referenced in the sequence of operation, temperature sensors should be identified by the Aquastat Fraction (see definition in the Glossary).

3.3.5 Qualified Piping Configurations

Vendor-provided HPWH system piping schematics shall align with one or more of the following qualified piping configurations as mentioned in Section 3.3.4 and illustrated in Figures 2 through 8. Although not shown in the diagram, a primary loop, using a heat exchanger between the heat pumps and the primary storage, may be used to provide a freeze-protected glycol loop and/or to protect the heat pump's internal heat exchanger.

1. Single-pass HPWH
 - a. No hot water circulation, primary heat pump water heating only (Figure 2)
 - b. Hot water circulation returned to primary storage (Figure 3)
 - c. Hot water circulation returned to a temperature maintenance tank in series, also referred to as a “swing tank” (Figure 4)
 - d. Hot water circulation returned to a temperature maintenance storage tank in parallel with multi-pass HPWH for reheat (Figure 5)
2. Integrated HPWH
 - a. Integrated HPWH, no hot water circulation (Figure 6)
 - b. Integrated HPWH, hot water circulation returned to primary storage (Figure 7)
3. Multi-pass HPWH
 - a. Hot water circulation returned to primary storage (Figure 8)

Figure 2. Single-Pass Primary HPWH System without HW Circulation

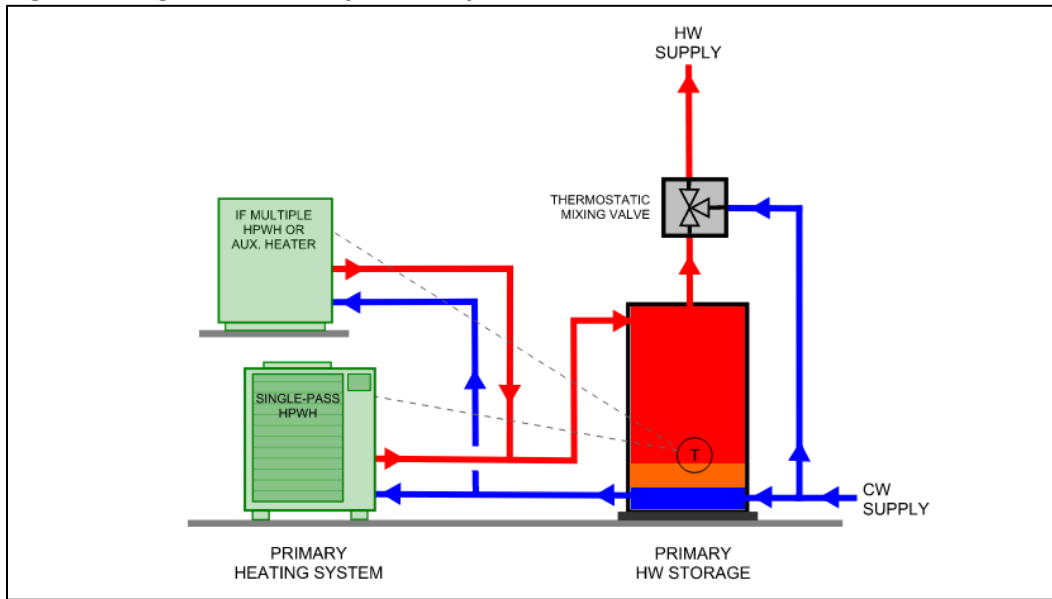

Figure 3. Single-Pass Returned to Primary

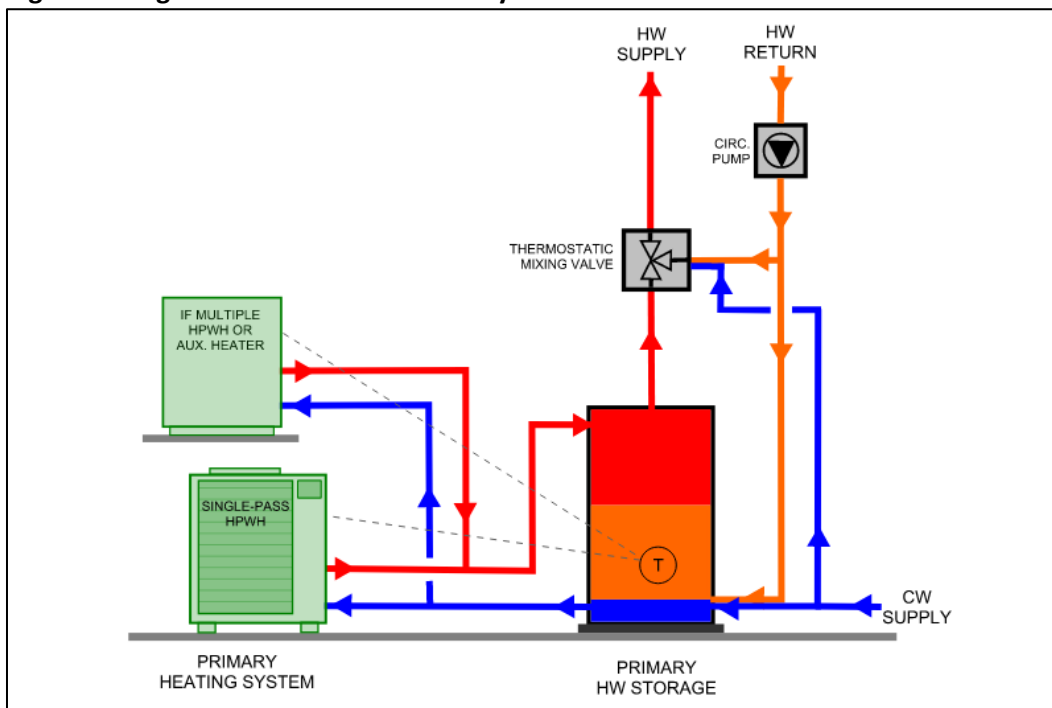

Figure 4. Single-Pass Swing Tank

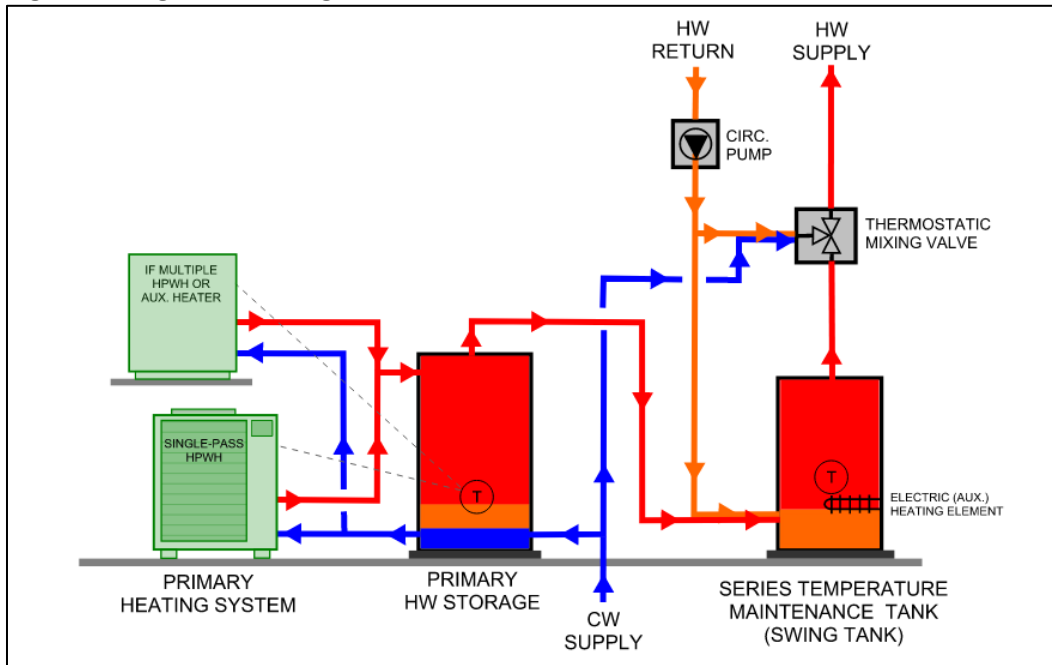

Figure 5. Single-Pass Parallel Loop Tank

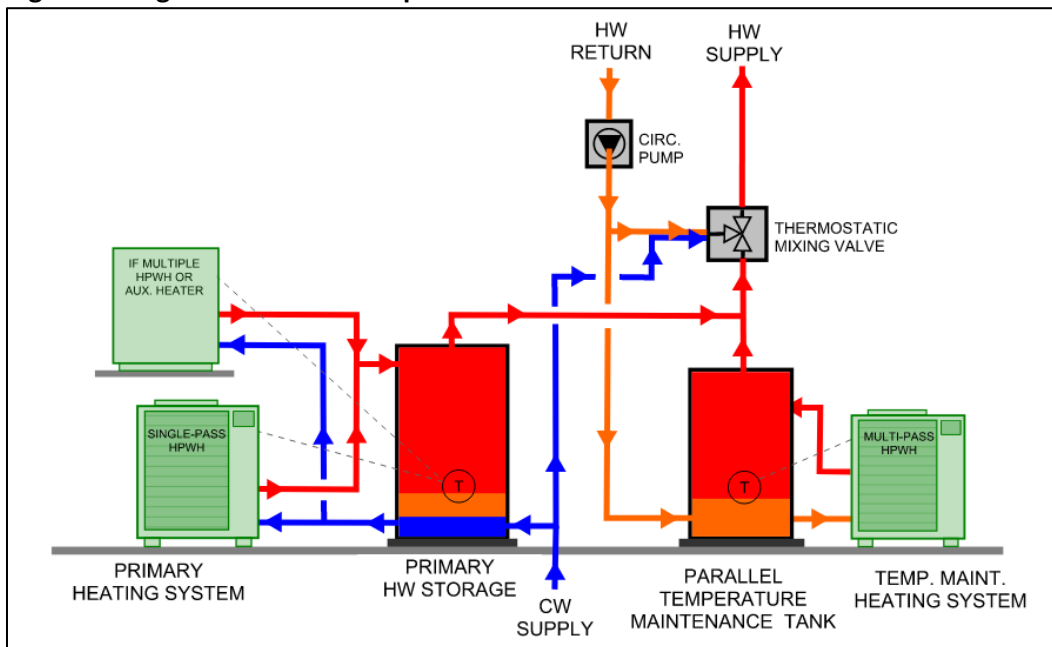

Figure 6. No Recirculation Integrated HPWH

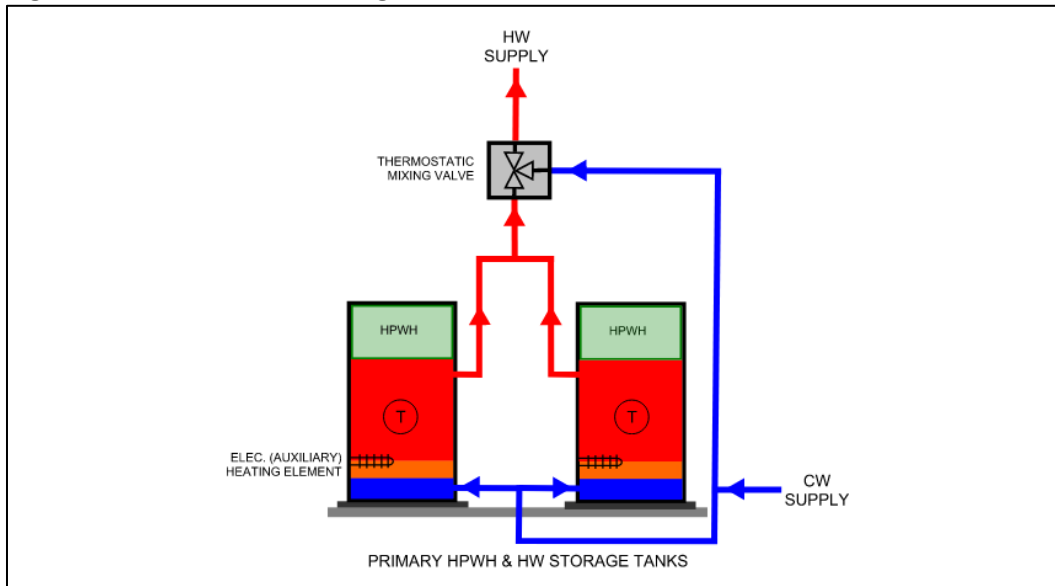

Figure 7. Integrated Returned to Primary HPWH

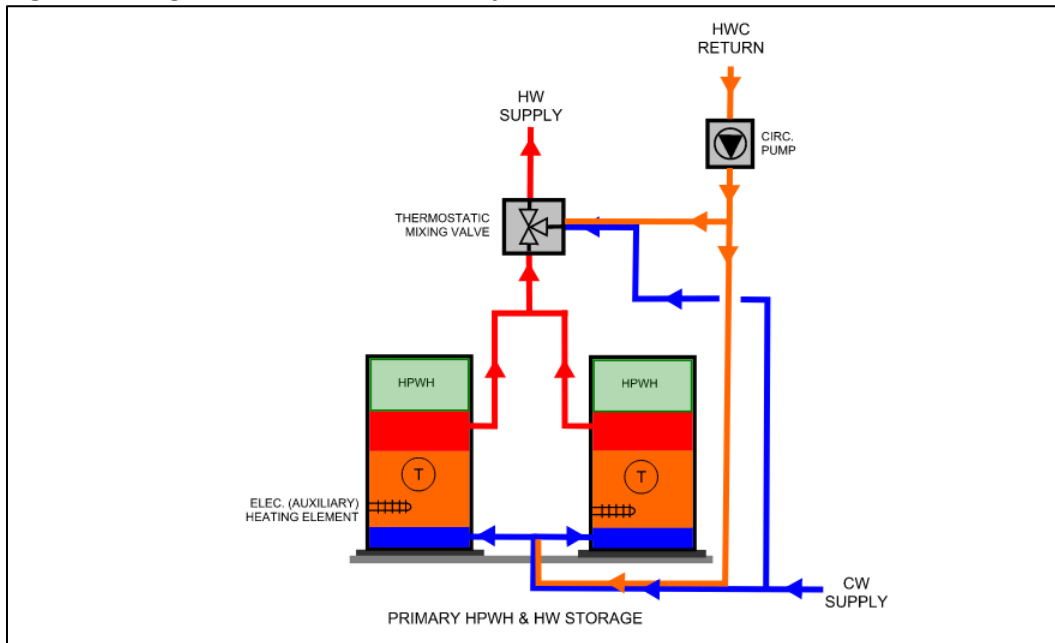
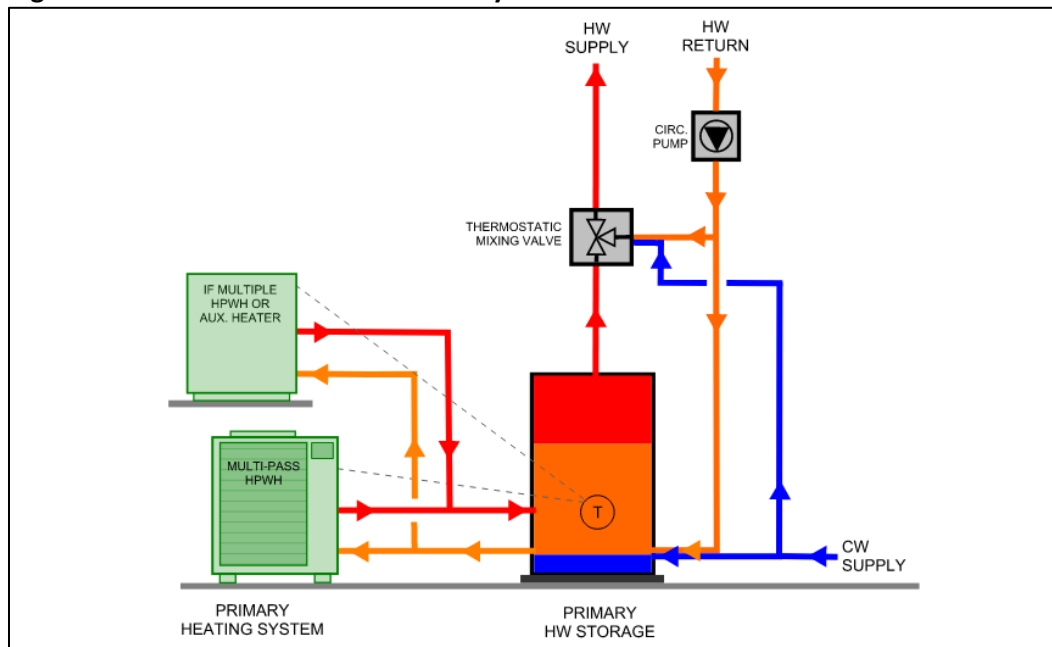

Figure 8. Multi-Pass Returned to Primary

3.3.6 Optional Demand Response Capability

Though demand response capability is not required for inclusion of a product line on the Qualified Products List, it may be incentivized or required by local codes as local context deems appropriate. For a product to be considered demand response capable when listed on the Qualified Products List, it must include all of the following:

1. The CHPWH shall have a CTA-2045B port (recently renamed EcoPort^{CM}).
2. The Sequence of Operations shall include standard controls adjustments for each EcoPort request designed to shift load from Shed periods to Load Up periods.
3. The product shall be listed as an EcoPort certified product⁵ or be tested, verified, and listed per AHRI 1430 or 1530.

3.4 Modeled Commercial/Multifamily System Performance

This section describes modeled CHPWH system efficiency, which includes the HPWH, storage, mixing valve, circulation pump, controls, and monitoring.

3.4.1 Commercial HPWH System Efficiency Modeling

Commercial HPWH system coefficient of performance (SysCOP) is calculated using a NEEA-approved calculator built into the Product Assessment Datasheet (PADS). All systems listed on the Qualified Products List (QPL) include a SysCOP calculated using the same NEEA-approved calculator. The calculator has been validated through comparisons with lab test data to ensure accuracy, the calculations used are documented in Appendix F, and the calculator is published in a form that allows manufacturers and interested parties to scrutinize the methods used.

⁵ <https://ecoport.openadr.org/>

Modeling is currently performed by AWHs administrators using the following manufacturer-submitted data:

1. HPWH performance and efficiency data identified in Section 3.3.3
2. Type of performance map data provided: lab data, field data, or simulated data
3. If lab data is provided, the manufacturer must indicate whether it was tested per AHNSI/ASHRAE Standard 118.1 tolerances and setup
4. If a secondary heat exchanger is required, and the performance map was tested without the secondary heat exchanger, a 10° heat exchanger lift is assumed.
5. Manufacturer-recommended piping configuration(s) that align with one (or more) of the qualified piping configurations in Section 3.3.5
6. The manufacturer-recommended primary storage temperature setpoint (140°F is the minimum allowable)

In combination with the following publicly available data:

- Air temperature data representative of 16 International Energy Conservation Code (IECC) climate zones⁶
- Assumed DHW circulation heat loss equal to 60 Watts per apartment when applied to configurations with a DHW circulation loop, informed by multifamily DHW heat loss research.⁷ 60 Watts per apartment is the estimated average for new construction multifamily buildings, built under modern energy codes, with well-insulated recirculation piping.

The annual SysCOP for each manufacturer-submitted product with a unique performance map is calculated for each qualified piping configuration recommended by the manufacturer. Modeling is repeated for each of four AWHs Climate Zones — hot, mild, cold, and extremely cold. AWHs Climate Zones are derived from IECC Climate Zones, as shown in

Table 3. Weather data used in the SysCOP calculator is weighted by population. The results are utilized to define the Commercial HPWH System Efficiency Tier of a product on the Qualified Products List, identified in

Table 3.

3.4.2 Commercial HPWH System Efficiency Tiers

The SysCOP modeled for each configuration of each CHPWH product line may qualify for one of four tiers in each of the four climate zones to which it is applied. The SysCOP required to qualify for each tier in each climate zone is shown in

Table 3 below. When a CHPWH system does not meet the SysCOP requirements listed in Table 3, it may be listed as a Tier 0 product. Each product line's tier qualification is published in the Qualified Products List.

⁶ Source: <https://energyplus.net/weather> or Wilcox, S. and W. Marion. 2008. *User's Manual for TMY3 Data Sets*, NREL/TP-581-43156. April 2008. Golden, Colorado: National Renewable Energy Laboratory.

⁷ Kintner, P., and Larson, B. Literature Review of Multifamily Central DHW Distribution Losses. 2019.

Table 3. CHPWH System Efficiency Tiers

	Minimum SysCOP			
	Hot Climate (IECC Zones 1–2)	Mild Climate (IECC Zones 3–4)	Cold Climates (IECC Zones 5–6)	Extremely Cold Climates (IECC Zones 7–8)
Tier 1	1.75	1.50	1.25	1.15
Tier 2	2.25	2.00	1.60	1.50
Tier 3	2.75	2.50	2.25	2.15
Tier 4	3.50	3.00	2.75	2.50

3.4.3 Market Delivery Methods

AWHS v8.1 recognizes that CHPWH systems can be brought to market in various ways. The three primary market delivery methods are:

- Fully Packaged Systems
- Fully Specified Systems
- Custom Engineered Systems

Experience has shown that Fully Packaged Skid-Mounted and Fully Specified Built-Up System installations tend to be more reliable and are more likely to operate at the expected efficiencies. Custom Engineered Systems are susceptible to issues related to design, installation, and startup that can affect system performance. Performance validation steps, aligning with the needs of each delivery method, are recommended to ensure proper system operation. Definitions of the three market delivery methods, along with the suggested performance validation steps, are identified below:

2.4.5.3 Fully Packaged System

An all-in-one package that can be shipped and installed as a complete solution to serve a specific number of occupants and/or dwelling units. At minimum, this includes the following components: the primary HPWH(s), the primary storage tank(s), the temperature maintenance system (when present), all ancillary piping components, and a control system. The systems are designed, configured, and built up as a complete functional domestic hot water system in which all the components in the listing are the same with each installation. Proper assembly instructions are included when shipped.. Integrated CHPWH products may be considered Fully Packaged Systems when the mixing valve and recirculation pump models are specified in the listing.

Recommended performance validation step:

- System startup performed by vendor-authorized service provider

2.4.5.4 Fully Specified System

A fully specified package of parts, pieces, controls, and design assistance provided by a single seller, distributor, or company that comprises everything needed for a commercial HPWH system (“parts and smarts”). It includes the heat pump and specifications for the heat pump system, allowable piping configuration, schematics, sequences of operations, and at a minimum, guideline specifications for all major commercial HPWH system components that comprise a fully functional system (HPWH(s), storage tank(s) temperature maintenance system, circulation pump(s), mixing valve, auxiliary heaters, and controls). This follows the Variable Refrigerant Flow (VRF) model in which everything needed for a complex field-installed system is provided by a single manufacturer and designed to work together as a system.

Recommended performance validation steps:

- Field review of system installation by vendor-authorized service provider
- System startup performed by vendor-authorized service provider

2.4.5.5 Custom Engineered System

A system that typically requires engineering design and support. It represents systems for which a single seller, distributor, or company supplies only the CHPWH components without design specifications for the entire commercial CHPWH system. In custom engineered systems, the project-specific Engineer of Record selects and specifies the components that make a commercial CHPWH system, including the storage tank(s), temperature maintenance system, circulation pump(s), mixing valve, auxiliary heaters, and storage tank controls, which are then typically purchased and installed by a contractor.

Recommended performance validation steps:

- CHPWH system vendor approval of system design
- Review of component submittals and field review of system installation by Engineer of Record
- System startup performed by manufacturer-authorized service provider
- Documented functional performance testing to include verification of system operation, programmed set points, and programmed alarms
- Measurement and Verification system installed in accordance with Appendix H

3.5 Resources

Both the Product Assessment Datasheets (PADS) and the Qualified Products Lists are available at <https://neea.org/our-work/advanced-water-heater-specification>.

4 Industrial Water Heating Systems

This chapter covers the specification for industrial water heating systems — this is a placeholder for discussion of this technology. NEEA and the industry will work on this in future iterations.

4.1 Purpose of Industrial Specification

4.2 Industrial Specification Scope

4.3 Industrial System Definition

4.4 Industrial Applications

Appendices

Appendices A through J on the following pages detail information found earlier in this specification. Table 4 clarifies the types of HPWHs to which each Appendix applies.

Table 4. Appendix Titles and HPWH Specification Applications

Appx	Title	Applies to...		
		Residential	Commercial	Industrial
A.1	Test and Calculation Procedures	Yes	No	
A.2	Compressor Cutoff Temperature	Yes	No	
A.3	High Volume Draw Test	Yes	No	
A.4	Temperature Range Performance Testing — Split Systems	Yes	No	
B	Freeze Protection Test	Yes	No	
C	Sound Pressure Measurement Test Method	Yes	No	
D	Qualification Process	Yes	Yes	
E	Disqualification, Tier Reassignment, and Requalification Process	Yes	Yes	
F	CHPWH System Performance Calculator	No	Yes	
G	Low GWP Refrigerants	Yes	Yes	
H	Commercial System COP Measurement and Verification Requirements	No	Yes	
I	Product Assessment Datasheet (PADS) Document	Yes	Yes	
J	Commercial Integrated Performance Map Test Procedure	No	Yes	

Appendix A.1: Test and Calculation Procedures

This appendix contains the test and calculation procedures associated with the requirements set forth in this Advanced Water Heating Specification. The tests include the following:

- E₅₀ — Efficiency based on the U.S. Department of Energy (DOE) 24-hour simulated use test, but at 50°F ambient air
- E₉₅ — Efficiency based on the DOE 24-hour simulated use test, but at 95°F ambient air
- Compressor cutoff temperature
- High-volume draw test
- Freeze protection test (some units)
- Sound measurement

A.1.1 Temperature Range Performance Testing — Integrated Units

Overview: Measure the performance of the heat pump water heater equipment over a range of ambient air operating conditions.

Definitions:

E₉₅ – Efficiency based on the DOE 24-hour simulated test, but at 95°F ambient air

E₆₇ – Uniform Energy Factor from the standard DOE 24-hour test, at 67.5°F

E₅₀ – Efficiency based on the standard DOE 24-hour test, but at 50°F ambient air

Test Setup and Procedure

E₆₇: Follow standard DOE 24-hour test procedure (Section 5 of 10 CFR Pt. 430, Subpart B, App. E)

E₅₀: Follow standard DOE 24-hour test procedure with the following adjustments:

- Ambient conditions shall be 50°F dry bulb, 43.5°F wet bulb (58% RH)
- Inlet water temperature: 50°F

E₉₅: Follow standard DOE 24-hour test procedure with the following adjustments (note this test is *optional*):

- Ambient conditions shall be 95°F dry bulb, 82°F wet bulb (40% RH)
- Inlet water temperature: 67°F

Calculation Method

Calculate E₅₀ and E₉₅ by following the procedure from the DOE 24-hour test (Section 5 of 10 CFR Pt. 430, Subpart B, App. E) except substitute the respective ambient and inlet water temperature conditions. Retain the E₅₀ and E₉₅ values for documenting on the Product Assessment Datasheet.

A.1.2 Cool Climate Efficiency Calculation Climates (5–6)

Overview: Calculate a Cool Climate Efficiency (CCE) representative of water heater performance for equipment installed in semi-conditioned (e.g., basements, unheated utility rooms) and unconditioned (e.g., garages, crawl spaces) locations in cool climates.

Determining the CCE consists of lab measurement of efficiency at 67°F and 50°F (Uniform Energy Factor (UEF) and E_{50}), compressor cutoff temperature, and a temperature bin-based calculation procedure.

Definitions

CCE: Cool Climate Efficiency as defined throughout this section

E_R : Efficiency for the HPWH operating in resistance-only heat mode (see Equation 8)

C_{cutoff} is the compressor cutoff temperature (see Appendix A.2)

Calculation Method

The CCE utilizes a temperature bin weighted calculation.⁸ The temperature bins for use in the CCE weightings are shown in Table 5. Figure 9 two pages hence provides several graphical examples of the end result of the calculation.

Table 5. Temperature Bins⁹

j	T_j (°F)	f_j
1	77	0.021
2	72	0.121
3	67	0.124
4	62	0.131
5	57	0.132
6	52	0.141
7	47	0.121
8	42	0.096
9	37	0.071
10	32	0.040

The Cool Climate Efficiency is calculated as:

$$CCE = \sum_{j=1}^{10} E_j * f_j \quad (1)$$

where:

j is the bin number from Table 5

f_j is the fraction of hours for that bin

⁸ The method is based on the Heating Seasonal Performance Factor (HSPF) method for space conditioning heat pumps.

⁹ T_j gives the bin center. For example, the 62°F bin covers the 5-degree range 59.5°F to 64.5°F. “ f ” is fractional number of days per year in each of the temperature bins. The temperatures are daily averages for the dry bulb temperature in the buffer space. Climate data comes from TMY datasets of six cold climate cities (Boston, Chicago, Indianapolis, Minneapolis, Omaha, and Seattle). These temperatures are based on typical garage and unheated basement temperatures for houses in cold climates (weighting between garages and basement locations is 50/50). Temperature data are derived from simulated garage and unheated basement temperatures in different climates using SUNCODE (for garages) and SEEM (for basements) modeling tools. The garage scenario shares 1.5 of the walls with the house and 2/3 of the ceiling area. The other surface areas are exposed to the outside, attic, or ground. The garage area is 484 ft² with two car doors. The outside walls are insulated to a nominal value of R-19. The basement scenario has a 1,344 ft² basement with 7 ft ceilings. As the basement is unconditioned, neither the basement walls nor the floor is insulated.

E_j is determined in the following way:

If **no resistance heat** is used in either the UEF or E₅₀ test:

$$E_j = (T_j - 50) * m_{CCE} + E_{50} \quad (2)$$

where:

T_j is the bin temperature

m_{CCE} is the slope of the line connecting the two measured energy factors:

$$m_{CCE} = (E_{67} - E_{50}) / (67.5 - 50) \quad (3)$$

If **resistance heat** is used during the E₅₀ test:

For bin temperatures <50°F:

$$E_j = (T_j - 50) * m_{compT50} + E_{50} \quad (4)$$

where:

j is the temperature bin below 50°F and

$$m_{compT50} = (E_{50} - E_{R,Ccutoff}) / (50 - C_{cutoff}) \quad (5)$$

(the slope of the line connecting the measured E₅₀ and E_{R,Ccutoff} at the compressor cutoff temperature)

For bin temperatures ≥50°F and ≤67°F:

$$E_j = (T_j - 50) * m_{CCE} + E_{50} \quad (6)$$

where:

j is the temperature bin at, or between, 50°F and 67°F and

m_{UEF} is as defined in Equation 3

For bin temperatures >67°F:

$$E_j = E_{67} \quad (7)$$

(the efficiency beyond 67°F is capped at the 67°F value)

where:

j is the temperature bin above 67°F

For equipment that limits heat pump operation within the range of temperatures covered in Table 5 (regardless of resistance heat use at other temperatures), the efficiency for those temperature bins shall be assigned a value of E_R, where E_R is based on resistance element-only operation and the measured heat loss rate of the tank obtained during the E₆₇ test.

E_R is calculated for each temperature bin of resistance element-only operation as follows:

$$E_{R,j} = Q_{wtr} / (Q_{wtr} + Q_{stbdy,j}) \tag{8}$$

where:

Q_{wtr} is the energy input used to heat water over one day

Q_{stbdy} is the standby energy lost over one day

$$Q_{wtr} = m * c_p * \Delta T / \eta_{elem} \tag{9}$$

where:

m is daily water mass corresponding to the draw pattern used in UEF test (either very low, small, medium, or high; 10, 38, 55, or 84 gallons; 82.4, 313.1, 453.2, or 692.2 pounds)

c_p is 0.998 Btu/lb°F (heat capacity of water at 96.5°F)

ΔT is 75°F (125°F set point temperature – 50°F inlet water temperature)

η_{elem} is 0.98 heating efficiency of electric element per DOE test procedure

$$Q_{stbdy,j} = UA * (T_{tank} - T_j) * 24 \text{ hrs} \tag{10}$$

where:

UA is the measured tank heat loss rate (Btu/hr°F) from the E_{67} test

T_{tank} is 125°F (the tank set point temperature)

T_j is the bin temperature

Figure 9. CCE vs. Temperature¹⁰

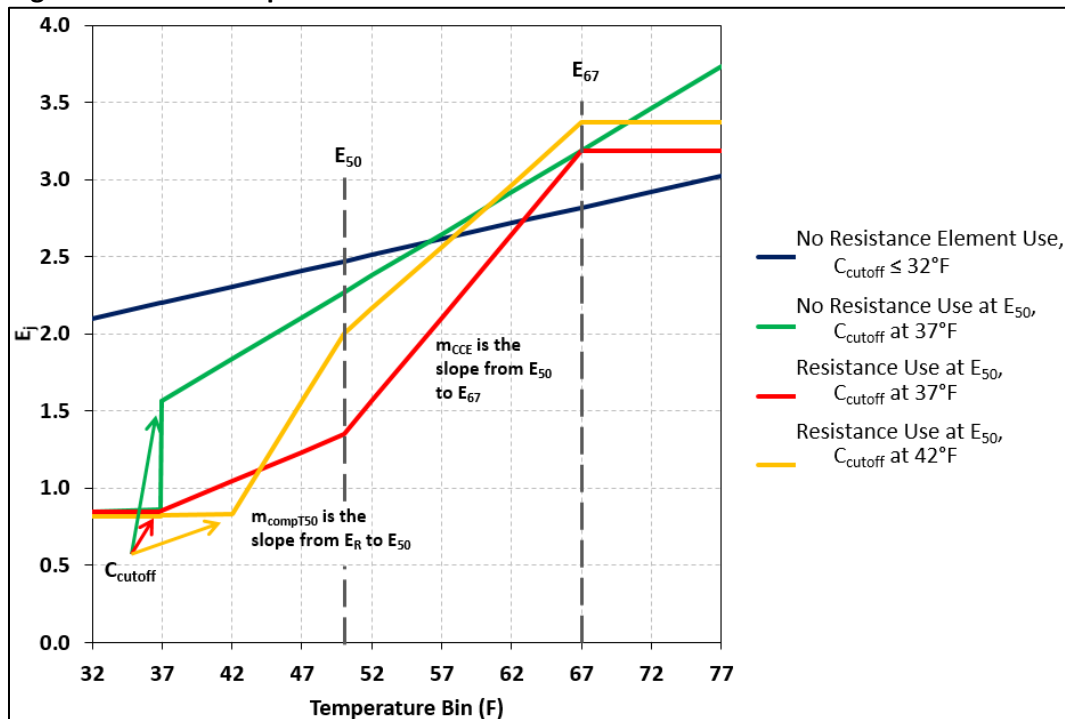

¹⁰ Note the CCE calculation procedure is designed to avoid giving undue benefit to using resistance elements at the 50°F condition. With the two test points used in the calculation, if no resistance element is used at 67.5°F but it is used at 50°F, the slope of the line connecting the two points will be artificially steep. An unduly steep slope leads to over-prediction of performance at temperatures above 67.5°F. Consequently, if resistance heat is used at 50°F but not at 67.5°F, the calculation procedure caps the predicted performance in the warmest temperature bins.

A.1.3 OPTIONAL: Warm Climate Efficiency Calculation (1–4)

The specification does not define a specific warm climate efficiency calculation; however, it provides the means with which to calculate one. The calculation may be useful in demonstrating product applicability and expanding market reach in warm climates. To estimate energy performance in warmer climates, use the temperature bin method analogous to calculating CCE. In that case, the procedure would use a temperature profile appropriate for the climate or installation of interest. Likewise, use the E₉₅ test result, if available, and linearly interpolate performance for temperatures between that and the E₆₇ result. If the E₉₅ test result is not available, use the E₅₀ and E₆₇ results to extrapolate performance. The overall accuracy of the calculation is likely to be improved, compared to the extrapolation, if an E₉₅ result is available.

Appendix A.2: Compressor Cutoff Temperature

Overview: A method to determine the low-end ambient temperature below which the compressor does not operate. The cutoff temperature is one of the variables in the Cool Climate Efficiency calculation. Determine the compressor cutoff temperature to within 5°F corresponding to the temperature bin centers in Table 5.

This is an *optional* test. A manufacturer may choose to self-report the compressor cutoff temperature, C_{cutoff} , and use that in the Cool Climate Efficiency calculation. If using the self-reporting method, and the reported temperature does not match one of the temperatures in Table 5, round the value to the nearest entry in the table. For example, 40°F shall be rounded to the 42°F bin and 39°F shall be rounded to the 37°F bin.

If the compressor cutoff temperature is not known (i.e., the self-reporting method is not used), conduct the test as described here to ascertain that temperature.

Test Setup

Set inlet water temperature, $T_{\text{inlet water}}$, to 50°F.

To start the test, establish normal water heater operation with the water heater outlet temperature at a set point of 125°F. Initiate a draw at 3gpm and withdraw a minimum of 10 gallons. More water shall be withdrawn if needed to achieve compressor cut-in. For example, a large capacity storage tank may require more water to be withdrawn to achieve a compressor cut-in depending on the water heater thermostat dead band.

Test Procedure

The ambient conditions shall be varied as necessary to determine the cutoff temperature. To start, the ambient temperature shall be the closest temperature bin center to the cutoff temperature specified by the manufacturer. For example, if the specified cutoff temperature is 45°F, the test shall be started at 47°F (if specified temperature is 23°F, start at 22°F). If the compressor does not turn on in response to the draw at the first ambient condition, or fails to completely recover the tank with the compressor only, increase the ambient temperature by 5°F and repeat the test. Repeat this procedure until an ambient condition is achieved under which the compressor operates. All tests shall be conducted with an ambient RH of 60%. Record the lowest temperature bin in which the compressor operates. For purposes of Cool Climate Efficiency calculations, the compressor shall be assumed to operate over the entire temperature bin.

Appendix A.3: High Volume Draw Test

Overview: The High Volume Draw Test uses a demanding hot water draw pattern to reveal the conditions under which a unit may transition to electric resistance heating, which may either supplement or replace compressor heating. A significant goal of the AWHs is to provide electric utilities and hot water users with a product that maximizes energy savings over electric resistance water heaters. Any time resistance elements are used in hybrid water heaters, that savings is not realized. Energy savings vetting activities by the Regional Technical Forum¹¹ and field measurements by others¹² have demonstrated the need to better understand when resistance heating is used.

This test is intended to elicit electric resistance element use and may stress the capability of the water heater. The test output will be used to inform and calibrate predictions/simulations of HPWH energy use. The test is neither a simulated use test nor a direct rating test nor a representation of an average day; rather, its goal is to better inform when resistance elements are used. Consequently, the tank may run out of hot water during the test. This is an acceptable, even expected, outcome and testing should continue.

This test must be conducted only for equipment that uses electric resistance heating in its default operating mode under standard operating conditions. For equipment without resistance elements or without element use in default mode, this test is not required.

The draw profile is 18 hours long and contains three clusters of water draws. The test is conducted at 67.5°F ambient air and 58°F inlet water.

Test Setup

Follow setup procedure for DOE tests (Section 5.2 of 10 CFR Pt. 430, Subpart B, App. E).

Verify water heater is in the default operating mode.

Use the draw pattern in

Table 6 corresponding to the nominal tank size. If the nominal tank size is within two gallons of any of the tank sizes given in the table, use the closest size. If the water heater under test does not match any of the given tank sizes, calculate an appropriate draw profile scaled to the 50 gallon profile as follows: Divide the nominal tank size of the unit in question by 50 gallons and multiply each draw amount (in the 50 gallon profile) by that scalar. Do not change the flow rate; instead, change the draw duration. For instance, the first draw for a 55 gallon tank would be 5.5 gallons.

For larger tank sizes, some draws will not be completed before the start time of the following draw. In these cases, delay the following draw, to begin when the preceding draw ends.

¹¹ Regional Technical Forum *Heat Pump Water Heaters UES Measure* <https://rtf.nwccouncil.org/measure/hpwh> and RTF *Research Plan: Residential Heat Pump Water Heaters*. November 9, 2016. <https://nwccouncil.app.box.com/s/ftk0313lker7gw54pza9nadfxg4l2q7>.

¹² *Heat Pump Water Heater Model Validation Study*. Ecotope 2015. Prepared for Northwest Energy Efficiency Alliance. <https://neea.org/resources/heat-pump-water-heater-model-validation-study>

Table 6. High Volume Draw Test Pattern

Draw Cluster	Minute	Flow Rate (GPM)	Draw Amount (Gallons) by Nominal Tank Size					
			40	50	60	65	70	80
1	0	3.0	4.0	5.0	6.0	6.5	7.0	8.0
	13	1.0	0.8	1.0	1.2	1.3	1.4	1.6
	43	1.0	0.8	1.0	1.2	1.3	1.4	1.6
	46	1.0	0.8	1.0	1.2	1.3	1.4	1.6
	49	1.0	0.8	1.0	1.2	1.3	1.4	1.6
	54	1.0	0.8	1.0	1.2	1.3	1.4	1.6
	79	3.0	27.2	34.0	40.8	44.2	47.6	54.4
	95	3.0	4.0	5.0	6.0	6.5	7.0	8.0
	116	1.0	0.8	1.0	1.2	1.3	1.4	1.6
	165	1.0	0.8	1.0	1.2	1.3	1.4	1.6
2	365	3.0	4.0	5.0	6.0	6.5	7.0	8.0
	377	3.0	4.0	5.0	6.0	6.5	7.0	8.0
	384	2.0	1.6	2.0	2.4	2.6	2.8	3.2
	412	2.0	1.6	2.0	2.4	2.6	2.8	3.2
	445	2.0	1.6	2.0	2.4	2.6	2.8	3.2
	450	3.0	18.4	23.0	27.6	29.9	32.2	36.8
	463	2.0	1.6	2.0	2.4	2.6	2.8	3.2
	490	2.0	1.6	2.0	2.4	2.6	2.8	3.2
3	690	3.0	3.2	4.0	4.8	5.2	5.6	6.4
	771	1.0	0.8	1.0	1.2	1.3	1.4	1.6
	775	1.0	0.8	1.0	1.2	1.3	1.4	1.6
	784	1.0	0.8	1.0	1.2	1.3	1.4	1.6
	804	1.0	0.8	1.0	1.2	1.3	1.4	1.6
	813	1.0	0.8	1.0	1.2	1.3	1.4	1.6
	865	3.0	18.4	23.0	27.6	29.9	32.2	36.8
	881	3.0	3.2	4.0	4.8	5.2	5.6	6.4
End Test	1080							
		Total Gallons Drawn						
		Cluster 1	40.8	51	61.2	66.3	71.4	81.6
		Cluster 2	34.4	43	51.6	55.9	60.2	68.8
		Cluster 3	28.8	36.0	43.2	46.8	50.4	57.6
		Overall	104.0	130.0	156.0	169.0	182.0	208.0

Test Procedure

Prepare the water heater for testing using the same initiation procedure as per the DOE 24-hour test.

Run 18-hour test using the appropriate scaled pattern from Table 6, recording all data.

Depending on tank size and controls, the hot water outlet temperature may drop below 105°F. This is an acceptable outcome for the test and testing shall continue.

Calculation and Reporting Procedure

To calculate the number of No-Electric Resistance Gallons:

Record the number of gallons drawn in each cluster, before the resistance element turns on, as follows: Note the minute in which the resistance element engages. Sum all the gallons drawn in the cluster prior to that minute and record as GC1, GC2, and GC3. Count the gallons only if the outlet water temperature is greater than or equal to 105°F. If no resistance element is used in the cluster, record as the total number of gallons drawn in the cluster. Retain for reporting on the Product Assessment Datasheet.

Appendix A.4: Temperature Range Performance Testing — Split Systems

Overview: This appendix, test method, and calculation procedure are currently in development. Split-system HPWHs shall be tested over a range of outdoor ambient air temperatures to determine their energy performance. CSA Group is currently developing a draft test procedure.¹³ When final, that test and rating procedure will be used within this specification. An outline of the current procedure follows.

The AWHs intends to require testing at the four conditions listed in Table 7. The test will consist of running the DOE 24-hour simulated use draw pattern at each set of conditions. An optional Temperature Operating Limit (TOL) is also included if the manufacturer wishes to measure and report an efficiency point below 5°F.

Table 7. Draft Testing Conditions for Split Systems

	Standard Outdoor Conditions			Inlet Water		Indoor Ambient Conditions
	Dry-Bulb Temperature, °F	Wet-Bulb Temperature, °F	RH (%)	Inlet Water Temperature, °F		Indoor Dry-Bulb Temperature, °F
A	5	2	30	42	67.5 ± 2.5	
B	34	31	72	47		
C	68	57	50	58		
D	95	69	25	67		
L1	TOL	TOL-1		37		

In addition to the test procedure, seasonal coefficient of performance (SCOP) calculation procedures will determine annual efficiency levels in different climates. The SCOP is an entirely different quantity from Cool Climate Efficiency (CCE); SCOP applies to split systems where the heat pump is subject to outdoor air conditions. Broadly, the method will consist of calculating an efficiency for each test in Table 7 following the Uniform Energy Factor calculation method but substituting in appropriate temperature conditions. This will yield COPs at four distinct ambient temperatures: COP_A, COP_B, COP_C, and COP_D. An overall SCOP will then be calculated using a temperature bin approach similar to that used for the Heating Seasonal Performance Factor (HSPF) for air-source heat pumps.

The temperature bin profile for the SCOP calculation, sourced from Typical Meteorological Year 3 (TMY3) data,¹⁴ is shown in Table 8. The draft reference climate for performance is a combination of the climates of five Pacific Northwest cities. The other climate temperature bin profiles are provided to aid in determining performance in other locations.

¹³ EXP10 - Load-Based and Climate-Specific Testing and Rating Procedures for Split System Air-to-Water Heat Pumps for Domestic Hot Water Service, CSA Group, <https://www.csagroup.org/standards/>

¹⁴ National Renewable Energy Laboratory (NREL) <https://nserdb.nrel.gov/data-sets/tmy>

Test Setup

Unit shall be tested with a 25ft standard length line set (if a manufacturer's system doesn't permit 25ft, it will be the maximum line length defined by the manufacturer). All supporting equipment including fans, pumps, line set insulation, and required heaters will be measured in total energy consumption for calculations.

Table 8. Draft Temperature Bin Profile for Split-System SCOP Calculation

f _j - Fraction of Year in Given Temperature Bin for Each Climate								
j	T _j (°F)	Pacific Northwest*	Minneapolis	Seattle	Los Angeles	Houston	Boston	Atlanta
1	102	0.000	0.000	0.000	0.000	0.001	0.000	0.000
2	97	0.003	0.001	0.000	0.000	0.011	0.001	0.001
3	92	0.005	0.005	0.000	0.000	0.047	0.004	0.022
4	87	0.010	0.014	0.002	0.000	0.068	0.012	0.054
5	82	0.019	0.036	0.009	0.003	0.112	0.027	0.067
6	77	0.029	0.057	0.018	0.018	0.175	0.051	0.100
7	72	0.045	0.076	0.039	0.108	0.135	0.085	0.136
8	67	0.064	0.083	0.062	0.249	0.100	0.087	0.104
9	62	0.096	0.066	0.103	0.300	0.089	0.088	0.101
10	57	0.135	0.059	0.168	0.202	0.071	0.088	0.091
11	52	0.143	0.063	0.183	0.090	0.065	0.088	0.086
12	47	0.133	0.061	0.154	0.026	0.045	0.084	0.064
13	42	0.121	0.071	0.148	0.002	0.041	0.090	0.071
14	37	0.086	0.060	0.074	0.000	0.024	0.101	0.042
15	32	0.057	0.083	0.030	0.000	0.012	0.081	0.025
16	27	0.030	0.069	0.007	0.000	0.003	0.043	0.022
17	22	0.013	0.060	0.001	0.000	0.001	0.032	0.010
18	17	0.006	0.052	0.000	0.000	0.000	0.024	0.001
19	12	0.002	0.024	0.000	0.000	0.000	0.009	0.001
20	7	0.001	0.018	0.000	0.000	0.000	0.004	0.000
21	2	0.001	0.012	0.000	0.000	0.000	0.000	0.000
22	-3	0.000	0.015	0.000	0.000	0.000	0.001	0.000
23	-8	0.000	0.009	0.000	0.000	0.000	0.000	0.000
24	-13	0.000	0.004	0.000	0.000	0.000	0.000	0.000
25	-18	0.000	0.001	0.000	0.000	0.000	0.000	0.000
26	-23	0.000	0.001	0.000	0.000	0.000	0.000	0.000

* A combination of the climates of five Pacific Northwest cities is used in the reference climate for SCOP calculation and rating. The cities, and their weighting fractions, are: Portland (0.20), Seattle (0.40), Boise (0.25), Spokane (0.10), and Kalispell (0.05).

Appendix B: Freeze Protection Test

Overview: For units circulating water outside the hot water tank for purposes other than delivery to the house (i.e., to a heat exchanger for heating), test the water heater's ability to withstand adverse environmental events and still remain functional afterward as defined in **Functionality** below.

Test Setup

- The ambient air in which the water heater is located shall be maintained at 20°F dry bulb for the duration of the test.
- Set tank delivery water temperature set point to 125°F.
- Set equipment to the default operating mode.
- Inlet and outlet water lines shall be insulated to provide an R value between 4 and 8 h-ft²-F/Btu for a minimum of two feet from the tank with 1" thick pipe insulation.

Test Procedure

- Establish normal water heater operation: if the water heater is not operating, initiate a draw. Terminate that draw when equipment cut-in occurs. When the tank recovers and the heaters cut out, wait five minutes, then shut off all power to the water heater for 24 hours.
- After 24 hours, turn on power to the water heater and allow it to recover to the set point.
- Initiate a draw until the water heater compressor cuts in. Allow tank to recover to the set point.
- Shut off power to the water heater and inspect for damage.

Functionality

The water heater will have passed the test if all the following criteria are met:

- The compressor runs and the tank recovers after the 24-hour off period.
- There is no freezing or rupture of any water-related connections or components, including but not limited to heat exchangers, pumps, condensate lines, or other heat pump components aside from the standard plumbing connections required for a traditional electric resistance water heater.

Appendix C: Sound Pressure Measurement Test Method

Overview: A simplified, repeatable test to measure sound pressure level. Future versions of this specification intend to adopt and use an industry consensus standard, when one arises, specifically designed to measure HPWH sound levels.

Test Setup

- The testing room shall approximate a typical garage, basement, or house utility room defined as follows: most surfaces are relatively hard — standard laboratory flooring materials such as concrete or linoleum, and cinderblock or drywall walls; the room need not be empty of other equipment, though other noise sources should be turned off. Efforts to dampen noise, such as applying anechoic tiles or baffles, shall not be performed. Measurements made in an anechoic or semi-anechoic style chamber are not valid.
- Place the water heater 6" away from one wall in the room.
 - All other walls or objects shall be at least 1.5 meters away from the water heater.
 - Ambient noise shall be at least 10 dBA less than the water heater being measured. For example, if unit under test is measured at 56 dBA, the ambient noise level may be < 46 dBA.
 - Unit shall be run without ducting attached for those units for which this is an option.
- Initiate normal water heater operation under an operating mode that uses all moving components simultaneously including, but not limited to, the compressor, fan, or pumps. Allow the unit to operate in this mode for one minute before proceeding and ensure that a steady state of operation is maintained during the entire sound measurement procedure.
- Environmental parameters are as follows:
 - DOE (required)
 - Inlet water temperature shall be 58°F ±5°F
 - Ambient air conditions shall be 67.5°F ±5°F
 - Cool Climate Efficiency (CCE) (optional)
 - Inlet water temperature shall be 50°F ± 5°F
 - Ambient air conditions shall be 50°F ± 5°F

Test Procedure

- Measure the A-weighted sound pressure level:
 - At five points one meter distant from the water heater surface at a 1.8 meter height above the base of the water heater (see Figure 10). Points 3L and 3R should be 12" from the wall.
 - If the water heater has an airflow intake or exhaust flow path around the circumference of the equipment, position the unit as follows, so the airflow is not directly aimed at a measurement point: aim the intake or exhaust between points (3L, 2L), (2L, 1), (1, 2R), or (2R, 3R). In no case should the flow path be directed between points (3L, 3R).
- Average all five measurements into a single sound value.

Figure 10. Test Setup for Sound Pressure Measurement

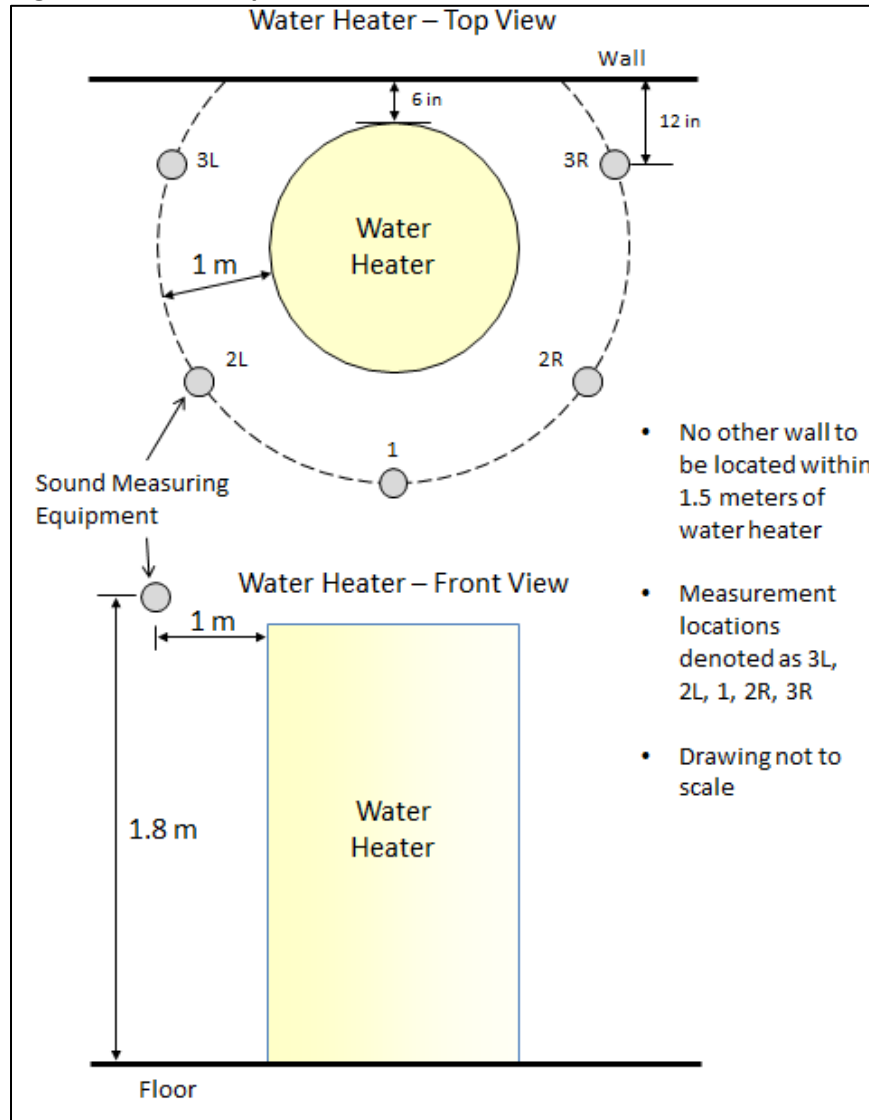

Appendix D: Qualification Process

For residential products, all the steps necessary for ENERGY STAR® qualification are required by the Advanced Water Heater Specification. Testing for residential products may take place at any lab the manufacturer is willing to stand behind and sign off on the attestation statement in the AWHs Product Assessment Datasheet (PADS).

For commercial products, the manufacturer must indicate on the PADS whether performance map data are gathered through lab testing, field monitoring, or software simulation. Where the manufacturer chooses to perform performance map lab testing, testing may be conducted in the manufacturers' facilities or through a third party. Manufacturers shall indicate on the PADS whether lab testing is performed per the setup, tolerances, and procedures outlined in ANSI/ASHRAE 118.1-2012.¹⁵

Note: All commercial products previously qualified to an earlier version of the specification shall remain qualified unless substantial changes are made to qualification requirements. If changes are made to the System COP calculation methodology, all products will be re-run through the same calculation to create even and comparable listings. The listing vendor will be notified prior to any change in listing status. If a product no longer meets AWHs requirements, or has been found to not comply in practice, the listing may be removed. A vendor will be notified six months prior to potential removal of a listing, and given that time period to address delinquencies.

The flow chart below illustrates a broad overview of the pre-AWHs activities and subsequent AWHs requirements (

Figure 11). The original equipment manufacturer (OEM) is responsible for taking the water heater through preparation of the referenced PADS, at which point it is handed off to the managing agency (currently the Northwest Energy Efficiency Alliance (NEEA)). If all requirements are met, the product will be listed on the Qualified Products List (QPL). The QPL is updated as needed to keep current with products on the market.

¹⁵ Only products tested per ANSI/ASHRAE 118.1 will qualify for utility programs through national agencies such as the Consortium for Energy Efficiency (CEE). NEEA encourages but does not currently require performance map testing through ANSI/ASHRAE 118.1.

Figure 11. Pre-AWHS Activities and AWHS Requirements

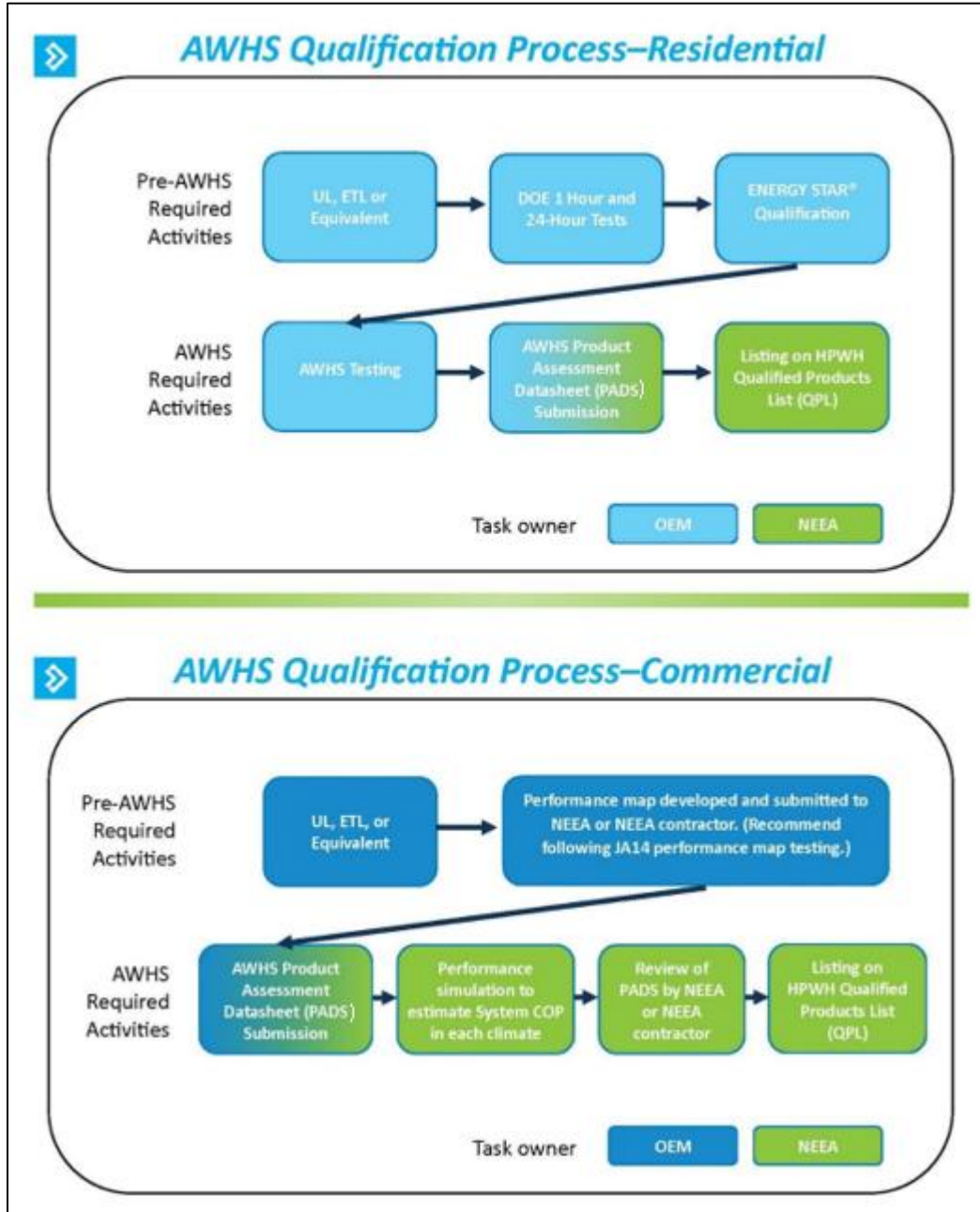

The AWHS qualification process for a residential or commercial product begins when a manufacturer submits the applicable HPWH Product Assessment Datasheet (PADS) to the managing agency (currently NEEA). The most current versions of these datasheets, to be completed by the manufacturer, are listed under “Additional Resources” at <https://neea.org/our-work/advanced-water-heater-specification>.

Manufacturers are encouraged to perform their own Advanced Water Heater Specification testing (or modeling, if a commercial product) or facilitate it through any third-party EPA-recognized laboratory.¹⁶ In the event the manufacturer does not provide a performance map per the requirements of this specification (and submits an incomplete assessment worksheet), qualification will be delayed until the managing agency or the manufacturer¹⁷ performs the requisite testing.

Upon meeting all the requirements for qualification, a product will be added to the Qualified Products List and classified into the appropriate tier level. For the current list, and for a complete description of the current process flow for the qualification process, see “Additional Resources” at <https://neea.org/our-work/advanced-water-heater-specification>.

¹⁶ See https://www.energystar.gov/index.cfm?fuseaction=recognized_bodies_list.show_RCB_search_form

¹⁷ For situations in which the manufacturer's testing results are self-reported and validated by NEEA or its designated managing agency

Appendix E: Disqualification, Tier Reassignment, and Requalification Process

This appendix is divided into two sections: Residential (A) and Commercial (B). The managing agency (see below) may evaluate any product on the QPL at any time to ensure that the product meets the requirements of the Advanced Water Heating Specification. The evaluation may result in any of the following:

- A product may remain qualified to the specification at its current tier level.
- A product previously qualified to the specification may qualify for a different tier level.
- A product previously qualified to the specification may no longer qualify.

Grounds for disqualification or re-assignment of products to a different tier level may be uncovered through any of the following scenarios, or through other scenarios that may arise:

1. Lab re-testing of new units or versions of the product
2. Inspection of the product in the event that certain product features available at the time of initial qualification are no longer commercially available
3. Discovery of substantial differences between in-field performance and lab-tested performance (greater than 5%) through in-field testing. “Substantial” is here defined as having a material impact on the aggregate performance in the population of products under study, such that the product in aggregate no longer qualifies for the tier level under which it was qualified.
4. Observation of product safety issues in the field, or discovery of issues in lab or field testing
5. Challenge to Qualified Products
6. Challenge to modeled system performance values

Residential

An entity (manufacturer, regulatory agency, advocacy group, or other party) may challenge the placement of a product on the QPL. The entity that brings forth the challenge must agree to pay for the challenge if the challenge does not find issue in the listing. If the challenge reveals that incorrect data have been provided, the product supplier that provided incorrect data must pay for the challenge. This challenge event consists of the following:

- The party challenging the results contacts NEEA or the current QPL managing agency in writing that potential discrepancies in test results may exist.
- The managing agency notifies the challenged party in writing and coordinates a mutually agreeable testing lab for verification testing.
- Random units are pulled from distribution and sent to the testing lab.
- The full cost of doing the test (including procurement, shipping, and testing) shall be borne by whichever of the two entities is found in error.

In all the above scenarios, NEEA or the current managing agency will share the findings and other relevant information with the HPWH Program and Technical Work Groups, the challenging party (if applicable), and the challenged party for review. Upon review, NEEA or the current managing agency may decide to proceed with the disqualification/tier reclassification, or to proceed no further for reasons such as lab or field testing errors, insufficient confidence in testing results, or administrative errors in the testing process. NEEA or the current managing agency may request that the challenged party provide additional information, or participate in additional third-party testing, to determine the outcome; such information and/or findings would also be shared with the challenging party in the case of a third-party challenge.

All parties involved shall proceed in a confidential manner during and after the challenge event. NDAs will be in place with all parties involved at the onset of a disqualification process. No party is to disclose any information regarding the challenge or the involved product and/or parties. NEEA or the current managing agency may reveal only the challenge outcome or may choose to reveal additional information material to the challenge event.

Upon deciding to proceed with disqualification/tier reclassification, NEEA or the current managing agency shall inform the challenged manufacturer and provide 20 days for a written response from the date of notice. NEEA shall share the written response (if any) with the HPWH work groups, gather feedback, make a final decision, and inform the challenged manufacturer and the challenging party of the decision. In the event that a previously qualified product is found to not meet specifications and/or the specified tier level, the product will be de-listed or relisted at a new tier level.

Once a product has been disqualified or assigned to a different tier level, the challenged manufacturer may petition for requalification or reassignment to the original tier level. The information provided in the petition (such as updated lab and field tests and/or manufacturing process or design changes) will be analyzed by NEEA or the current managing agency and shared with the existing incentive programs and/or technical work groups. At that point, a decision will be made and communicated to both the challenged and challenging parties.

Commercial

For commercial water heating systems, the QPL will be managed by NEEA. The process is similar to the residential process above, except that lab testing is not required or possible; instead, commercial HPWH system modeling software is used to determine performance. The biggest area for potential challenges resides in the underlying assumptions in the modeling software. Geography, amount of demand, and return temperatures will be the key variables. Modeling assumptions will be clearly defined in the product specification so that the “performance map data” are accurate to the location and installation.

In all the above scenarios, NEEA or the current managing agency will share the findings and other relevant information with the HPWH program and technical work groups, the challenging party (if applicable), and the challenged party for review. Upon review, NEEA or the current managing agency may decide to proceed with the disqualification/tier reclassification, or to proceed no further for reasons such as lab or field testing errors, insufficient confidence in testing results, or administrative errors in the testing process. NEEA or the current managing agency may request that the challenged party provide additional information, or participate in additional third-party testing, to determine the outcome; such information and/or findings would also be shared with the challenging party in the case of a third-party challenge.

All parties involved shall proceed in a confidential manner during and after the challenge event. NDAs will be in place with all parties involved at the onset of a disqualification process. No party is to disclose any information regarding the challenge or the involved product and/or parties. NEEA or the current managing agency may reveal only the challenge outcome or may choose to reveal additional information material to the challenge event.

Upon deciding to proceed with disqualification/tier reclassification, NEEA or the current managing agency shall inform the challenged manufacturer and provide 20 days for a written response from the date of notice. NEEA shall share the written response (if any) with the HPWH work groups, gather feedback, make a final decision, and inform the challenged manufacturer and the challenging party of the decision. In the event that a previously qualified product is found to not meet specifications and/or the specified tier level, the product will be de-listed or relisted at a new tier level.

Once a product has been disqualified or assigned to a different tier level, the challenged manufacturer may petition for requalification or reassignment to the original tier level. The information provided in the petition (such as updated lab and field test modeling and/or manufacturing process or design changes) will be analyzed by NEEA or the current managing agency and shared with the existing incentive programs and/or technical work groups. At that point, a decision will be made and communicated to both the challenged and challenging parties.

Appendix F: CHPWH System Performance Calculator

The Commercial Heat Pump Water Heater (CHPWH) System Performance Calculator estimates the annual energy efficiency (SysCOP) of any CHPWH system configuration outlined in the Advanced Water Heating Specification (AWHS) 8.1. The calculator is built into the Product Assessment Datasheet (PADS), which vendors use to submit new products for listing on the Qualified Products List. This appendix describes the algorithm used in the calculation.

The calculator uses lab-verified characteristics of each AWHS-aligned CHPWH piping configuration, climate-specific outside air temperatures (OAT), domestic cold water (DCW) temperatures, and manufacturer-provided performance map data to estimate how efficiently a CHPWH system will heat a given domestic hot water (DHW) load in a typical multi-family building. The assumed DHW load includes DHW usage and DHW circulation (temperature maintenance) heat loss. A comparison with lab data indicates the calculator has a less than 5% error when calculating system COP from performance map data.

Calculator Logic

The following logic does not need to be understood to use the calculator; it provides transparency into how SysCOP is calculated for listing on the QPL. The following sections outline the main calculator functions, what they are meant to accomplish, and how.

At a high level, the CHPWH System Performance Calculator is a bin calculation used to estimate the annual SysCOP of a CHPWH system in the four AWHS climate zones. However, the calculation includes adjustments for city water temperature, daily water usage, recirculation losses, and hot water supply and return temperatures, to accurately calculate the ratio of primary load to recirculation load. The ratio of primary load to recirculation load impacts the inlet water temperature in single pass return to primary configuration and the amount of swing tank electric resistance used in swing tank configuration.

Outside Air Temperature Bins

The table below shows the five outdoor air temperature (OAT) bins used in SysCOP calculations. All highlighted boxes are user inputs.

Table 9. Calculator Performance Map Input Table

Primary HPWH Performance Data							
	DB, °F	WB, °F	Inlet Water Temperature	Outlet Water Temperature	Input Power, kW	Output Heat, kW	COP
Lowest Temperature	0	-1	125	140	2.0	3.0	1.50
A	5	2	125	140	2.0	4.0	2.00
B	34	31	125	140	2.0	5.0	2.50
C	68	57	125	140	2.0	6.0	3.00
D	95	69	125	140	2.0	7.0	3.50

Other than the lowest temperature bin, which is selected by the vendor, OAT bins align with AWHS B.4.¹⁸

¹⁸ ANSI 340 AS-HPWH test conditions were considered. However, the conditions listed in ANSI 340 skip the range in which defrost most significantly impacts HPWH performance. NEEA's subcontractors elected to select temperature bins that will allow for defrost to be factored in once a defrost test has been written. OAT bins may be altered in the future to align with national standards when AHRI 1300 is published with new temperature bins.

Climate Zone Weather Data

The OAT bins are weighted based on the number of hours the equipment is expected to operate closest to that OAT for each AWHs climate zone. AWHs climate zones are broad enough to capture the entire US but discrete enough to illustrate climate’s impact on CHPWH SysCOP.

Hourly temperatures for each AWHs climate zone are selected by combining temperature profiles for several IECC zones:¹⁹

1. Each IECC zone is assigned a representative city whose TMY3 weather data provides hourly OAT.
2. Each IECC zone is assigned a population weight based on the population percentage it makes up in its AWHs climate zone.

The tables below show the IECC zones, representative cities, and weighting that make up climate zones.

Table 10. AWHs Hot Climate Zone

Hot		
0.245	0.674	0.081
1A	2A	2B
Honolulu, HI	Tampa, FL	Tucson, AZ

Table 11. AWHs Mild Climate Zone

Mild					
0.138	0.107	0.046	0.618	0.004	0.087
3A	3B	3C	4A	4B	4C
Atlanta, GA	El Paso, TX	San Diego, CA	New York, NY	Albuquerque, NM	Seattle, WA

Table 12. AWHs Cold Climate Zone

Cold				
0.679	0.161	0.002	0.139	0.018
5A	5B	5C	6A	6B
Buffalo, NY	Denver, CO	Port Angeles, WA	Rochester, MN	Great Falls, MT

Table 13. AWHs Very Cold Climate Zone

Very cold	
0.989	0.011
7	8
International Falls, Fairbanks, AK	

¹⁹ IECC Climate zones can be found in the 2021 International Energy Conservation Code: Section C301.

Mapping Weather Data to Temperature Bins for Efficiency Calculations

Temperature bins are reconfigured based on the minimum OAT at which the CHPWH can provide heat using its compressor. Then the number of hours a year the CHPWH system will operate in each temperature bin is calculated.

1. The coldest OAT bin is bounded by a CHPWH manufacturer input: The minimum OAT at which the CHPWH can provide the required outlet water temperature without supplemental electric resistance, referred to as the **min HPWH design temperature**. Below the min HPWH design temperature, the calculation assumes electric resistance heating is provided.
2. Temperature bin boundaries are set equidistant between each bin temperature. The warmest temperature bin covers all OATs above its lower boundary.
3. If the min HPWH design temperature is warmer than any of the listed temperature bins, those bins are omitted, and bin boundaries are re-configured.

The number of hours spent in each temperature bin will drive annual CHPWH system efficiency.

1. Note: all hours that are cooler than min HPWH design temperature are excluded from temperature bins and accounted for in a downstream energy calculation.
2. OAT bin hour tallies and bin boundaries are illustrated below for:
 - a. Min HPWH design temperature cooler than 5°F.
 - b. Min HPWH design temperature warmer than 40°F. Note the 5°F and 34°F temperature bins don't include any hours because they are cooler than min HPWH design temperature.

Table 14. OAT Bins and Bounds. Min CHPWH Design Temp: -1°F

Primary HPWH							
Air Temp Bins (°F)		Bin Bounds		Bin Hours Per Temp Per Climate Zone			
DB	WB	Min OAT	Max OAT	Hot	Mild	Cold	Very cold
-1	-2	-1.00	2.00	0.0	0.0	22.6	190.5
5	2	2.00	19.50	0.0	75.5	632.6	1114.8
34	31	19.50	51.00	415.4	3187.7	3889.3	3349.1
68	57	51.00	81.50	6430.7	4937.5	3909.5	3141.9
95	69	81.50	180.00	1914.0	559.3	232.2	125.7

Table 15. OAT Bins and Bounds. Min CHPWH Design Temp: 40°F

Primary HPWH							
Air Temp Bins (°F)		Bin Bounds		Bin Hours Per Temp Per Climate Zone			
DB	WB	Min OAT	Max OAT	Hot	Mild	Cold	Very cold
40	39	40.00	54.00	600.7	2211.2	1968.4	1576.3
5	2	54.00	54.00	0.0	0.0	0.0	0.0
34	31	54.00	54.00	0.0	0.0	0.0	0.0
68	57	54.00	81.50	6158.6	4332.4	3358.0	2722.3
95	69	81.50	180.00	1914.0	559.3	232.2	125.7

Storage and Heat Pump Outlet Water Temperatures

The user inputs a recommended storage temperature for the system, which must be above 140°F.

The average HPWH outlet water temperature is assumed to be the storage tank temperature, or the storage temperature +10°F if a heat exchanger that is not included in the performance map is required.

For multi pass systems, the outlet water temperature is not used in the calculation.

Domestic Cold-Water Temperature

A single, representative, domestic cold water (DCW) temperature for each AWHS climate zone is used in calculations of primary water heating load and the HPWH inlet water temperature. DCW is determined by:

1. The average monthly ground temperature in each IECC zone (TMY3 data, 4 meter depth) is assumed equal to average monthly DCW temperature.
2. The monthly DCW temperatures are used to calculate an average annual DCW temperature in each IECC zone.
3. Finally, population weights are used to calculate the average annual DCW temperature for each AWHS climate zone.

Usage and Temperature Maintenance Loads

The ratio of usage (or primary) water heating to temperature maintenance heating is used in calculations of inlet water temperatures and swing tank electric resistance usage.

1. The DHW usage per day per apartment (usage, gallons), DCW temperature per climate zone (T_{DCW} , °F), and DHW delivery temperature (T_{USAGE} , °F) drive average hourly DHW usage heating per apartment (Q_{USAGE} , BTU/hr):

$$Q_{USAGE} = 8.3 \times (\text{Usage}) \times (T_{USAGE} - T_{DCW}) / 24$$

2. The temperature maintenance (TM) heating – the amount of heat lost in the DHW circulation loop – per apartment is equal to the average hourly TM heating (Q_{TM} , BTU/hr). Values assumed in the qualified products list performance runs are:

$$Q_{TM} = 205 \text{ BTU/hr/apartment (60 Watts/apartment)}$$

$$T_{USAGE} = 125^\circ\text{F}$$

Heat Pump Inlet Water Temperature

Heat pump inlet water temperatures (IWTs) for each AWHs CHPWH system configuration are determined as described below:

1. **Swing tank and parallel loop tank configurations:** CHPWH IWT is assumed 15°F (adjustable) warmer than DCW temperature on average, based on lab test data.
2. **Single pass return to primary configuration:** CHPWH IWT is assumed equal to the average water temperature entering the bottom of the primary storage tank, which is a mix of DCW make-up and HWC return. These flows can be calculated by considering how primary storage provides heat to the two DHW loads:
 - a. Primary storage provides heat to the hot water circulation (HWC) loop by injecting water at storage temperature (T_{ST}) into the loop. The rate at which the storage tank injects water into the loop is equal to the flow rate of water that leaves the loop and enters the bottom of the hot water storage tank (F_{HWR_ST}). Therefore, (F_{HWR_ST}) is a function of hourly TM heating (Q_{TM} , equal to TM heat loss), storage temperature (T_{ST}), and HWC return temperature (T_{HWR}):

$$Flow_{HWR_ST} = Q_{TM} / 8.3 / (T_{ST} - T_{HWR})$$

- b. All DHW usage is provided by the primary storage tank and replaced with DCW:

$$Flow_{DCW_ST} = Q_{usage} / 8.3 / (T_{ST} - T_{DCW})$$

- c. The following equation is used to find the mixed temperature of $Flow_{HWR_ST}$ and $Flow_{DCW_ST}$ (T_{inlet_ST}):

$$T_{inlet_ST} = (Flow_{HWR_ST} \times T_{HWR} + Flow_{DCW_ST} \times T_{DCW}) / (Flow_{HWR_ST} + Flow_{DCW_ST})$$

- d. Figure 12 shows the Single pass return to primary configuration with associated flows and temperatures.

Figure 12. Single Pass Return to Primary Configuration

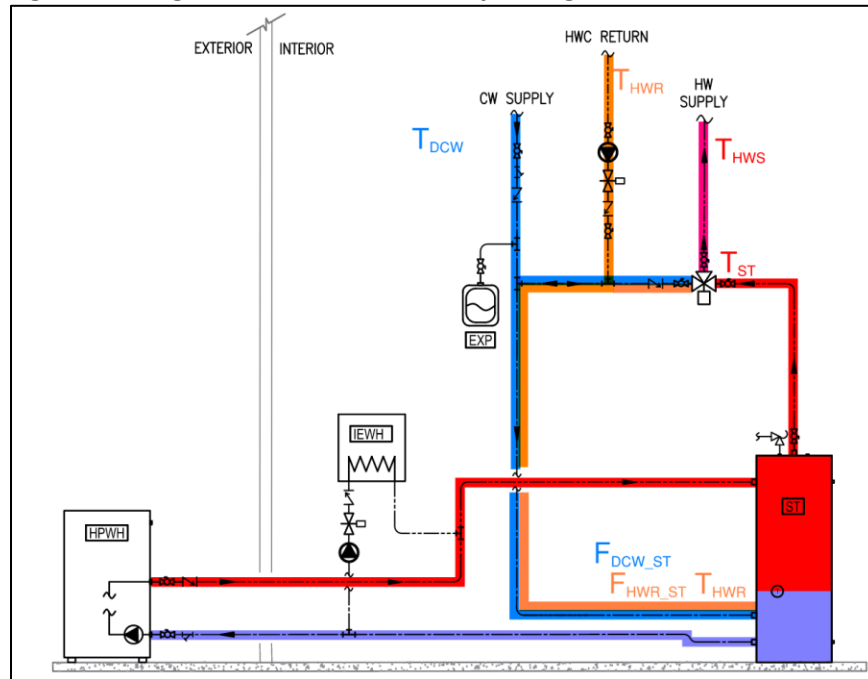

3. **Multi pass return to primary configuration:** CHPWH IWT is assumed 15°F cooler than storage temperature on average, based on lab test data. If a heat exchanger that is not included in the performance map is present, the IWT is assumed to be 5°F cooler than the storage temperature to account for heat exchanger temperature lift.

The inlet water temperature used in the calculator was calibrated and compared against lab testing of each system configuration. All lab tests were performed at 68°F outside air temperature and 58°F domestic cold-water temperature. Custom DCW and outside air temperature inputs (68°F air and 58°F DCW) were set in the calculator to compare the calculated HPWH IWT against lab results. Results from this comparison are shown in the table below.

Table 16. Comparison of Lab-Measured and Calculated HPWH Inlet Water Temperatures

HPWH IWT (°F) vs TM Heat Loss (W/apt) - Lab vs Calculated			
	TM Heat Loss: 50 w/apt 100 w/apt 150 w/apt		
TM In Series			
Average HPWH IWT - Lab	73	74	67
Average HPWH IWT - Calculated	73	73	73
Error	0.0%	1.4%	9.3%
TM in Parallel			
Average HPWH IWT - Lab	NA	75.2	NA
Average HPWH IWT - Calculated	NA	73	NA
Error	NA	2.9%	NA
Single Pass Return to Primary			
Average HPWH IWT - Lab	86	90	96
Average HPWH IWT - Calculated	84	94	99
Error	1.8%	4.0%	3.2%
Multi Pass Return to Primary			
Average HPWH IWT - Lab	121	124	127
Average HPWH IWT - Calculated	125	125	125
Error	3.2%	1.1%	1.6%

Inlet Water Temperature Weighting

For swing tank, parallel loop tank, and single pass return to primary configurations, when the IWT is based on the DCW, weighting is used to select a single IWT at each OAT bin. The calculation uses a single HPWH inlet water temperature for each OAT bin that is most accurate for climates that spend the most time in that bin. By using a single IWT, a single HPWH performance point can be reported per OAT bin, which reduces the required HPWH performance points reporting by a factor of 4 while still allowing for an accurate SysCOP estimation. The average DCW temperature for each OAT bin is determined through the following steps:

1. The average IWT for each climate zone is calculated based on the system configuration, DCW temperature in each climate zone, and usage and temperature maintenance loads as described in the previous section.
2. For each temperature bin, the IWT is weighted per climate zone against the number of hours spent in that temperature bin for each climate zone.
3. HPWH IWT calculation example: 68°F temperature bin:

Hours spent in 68°F temperature bin per climate zone:

Hot	Mild	Cold	Very cold
6,431	4,939	3,910	3,142

HPWH inlet water temperature per climate zone, °F:

Hot	Mild	Cold	Very cold
88	72	63	56

Calculation of weighted CHPWH IWT:

$$[(88 \times 6,431) + (72 \times 4,939) + (63 \times 3,910) + (56 \times 3,142)] / (6,431 + 4,939 + 3,910 + 3,142)$$

HPWH IWT in 68°F temperature bin: 73°F

Manufacturer-Reported HPWH Coefficient of Performance (COP)

Once the OATs, IWT, and OWT are defined, the performance map can be filled out and COPs may be calculated. Performance map data can be tested directly, simulated, or extrapolated from tested or simulated data.

1. HPWH manufacturer specifies system configuration, secondary HX requirement, primary storage temperature, and lowest operating temperature.
2. Performance data input sheet populates OAT, HPWH IWT, and HPWH OWT for each OAT bin.
3. The HPWH manufacturer or NEEA contractor enters input power and output heating for a given CHPWH model at the specified conditions in each OAT bin based on performance map data.
4. HPWH COP is calculated for each OAT bin.
HPWH COP = output heat / input power

Annual Energy Usage per Climate Zone

From the performance map data, the total electrical energy required by the CHPWH system (including HPWH, TM heater, and supplemental electric resistance) to satisfy DHW heating for a normalized, single dwelling unit for a full year, in each climate zone, is estimated.

1. For each temperature bin inside the HPWH operating envelope, per the climate zone:
 - a. The following equation is used to calculate annual CHPWH system energy usage (E_{in} , BTU) in each temperature bin for all configurations except swing configuration:

$$E_{in} = \text{total bin hours} \times (Q_{USAGE} / COP_{CHPWH} + Q_{TM} / COP_{TM_Heater})$$

$COP_{TM_Heater} = COP_{CHPWH}$ for the Return to Primary system configuration.

- b. In swing configuration, some TM heating is provided by the primary CHPWH (Q_{TM_CHPWH} , BTU/hr) and some TM heating is provided by the TM heater (Q_{TM_Heater} , BTU/hr), which is further explained in the following section. In this case:

$$E_{in} = \text{total bin hours} \times (Q_{USAGE} / COP_{CHPWH} + Q_{TM_CHPWH} / COP_{CHPWH} + Q_{TM_Heater} / COP_{TM_Heater})$$

The COP_{TM_Heater} is assumed to be 1 for an electric resistance swing tank.

2. During all hours cooler than min CHPWH design temp, the average heating load is assumed to be satisfied by electric resistance (ER):

$$E_{in} = \text{total hours} \times (Q_{USAGE} + Q_{TM}) / COP_{ER}$$

Assumed $COP_{ER} = 1$

3. Total energy usage of all annual operating hours is summed to result in total energy usage per climate zone.

Swing Configuration - TM Heating Provided by Primary HPWH

In the swing configuration, some TM heating is provided by the primary CHPWH because heat is transferred from primary storage to the TM tank as DHW usage flows from primary storage, through the TM tank, and to the DHW fixtures. Flow through the swing tank (F_{SW}) to satisfy DHW usage is a function of swing tank temperature (T_{SW} , °F), Q_{USAGE} , and T_{DCW} :

$$F_{SW} = Q_{USAGE} / 8.3 / (T_{SW} - T_{DCW})$$

Heat transferred from F_{SW} into the swing tank mixes with and elevates the temperature of HWC return also flowing through the swing tank. Therefore, TM heating provided by the primary HPWH (Q_{TM_HP}) can be calculated:

$$Q_{TM_HP} = F_{SW} \times 8.3 \times (T_{ST} - T_{SW})$$

Combining equations:

$$Q_{TM_HP} = Q_{USAGE} \times (T_{ST} - T_{SW}) / (T_{SW} - T_{DCW})$$

T_{SW} approaches primary storage temperature when TM heat loss is low compared to DHW usage, and approaches DHW usage temperature when TM heat loss is high compared to DHW usage. Average swing tank temperature is modeled as a linear interpolation between two points based on comparison against lab testing:

When $Q_{TM} = 50$ Watts / apartment, $T_{SW} = T_{USAGE} + 0.4 \times (T_{ST} - T_{HWS})$

When $Q_{TM} = 150$ Watts / apartment, $T_{SW} = T_{USAGE} + 2^{\circ}F$

The figure below outlines flows through primary storage and the swing tank.

Figure 13. Swing Configuration

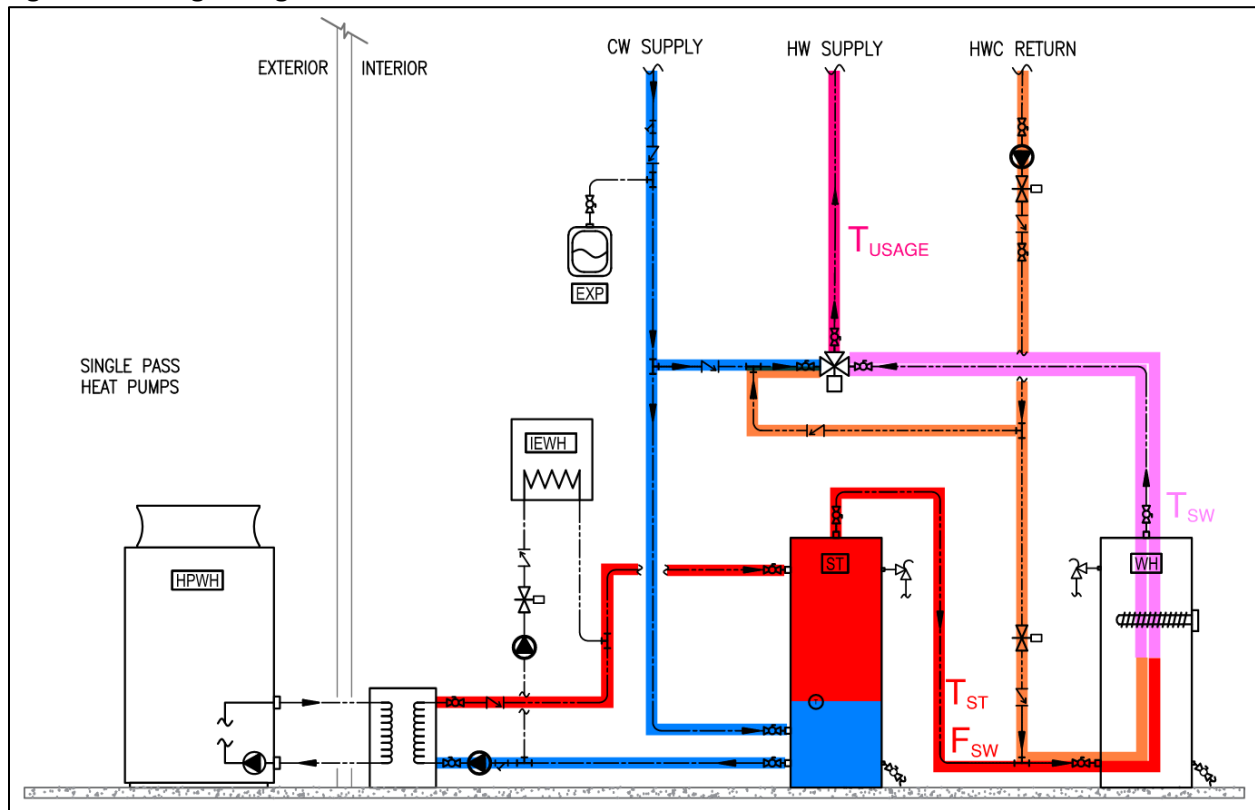

Annual System COP per Climate Zone

Once the electrical energy usage is calculated, the annual SysCOP can be calculated.

1. $SysCOP = E_{in_annual} / Q_{annual}$

$$Q_{annual} = (Q_{USAGE} + Q_{TM}) \times 8760 \text{ hrs/yr}$$

2. Results are unique to each climate zone.

COP - Lab Data Comparison

Lab-measured system COP was compared against calculated system COP using the same method as the HPWH IWT comparison. Lab-measured HPWH COP was input into the calculator’s performance table to eliminate the error between manufacturer-reported and lab-measured HPWH performance. Error between calculated and lab-measured System COP at lab conditions is below 6%.

Table 17. Comparison of Lab-Measured and Calculated System COP

System COP vs TM Heat Loss (W/apt) - Lab vs Calculated			
	TM Heat Loss: 50 w/apt 100 w/apt 150 w/apt		
<i>TM In Series</i>			
System COP - Lab	2.4	2.2	2.0
System COP - Calculated	2.2	2.0	1.9
Error	5.9%	5.8%	1.8%
<i>TM in Parallel</i>			
System COP - Lab	NA	2.5	NA
System COP - Calculated	NA	2.5	NA
Error	NA	0.9%	NA
<i>Single Pass Return to Primary</i>			
System COP - Lab	2.7	2.6	2.6
System COP - Calculated	2.7	2.6	2.6
Error	0.1%	0.1%	0.0%
<i>Multi Pass Return to Primary</i>			
System COP - Lab	2.4	2.3	2.4
System COP - Calculated	2.4	2.4	2.4
Error	2.6%	1.7%	1.3%

Appendix G: Low GWP Refrigerants

The Advanced Water Heating Specification does not currently take a position on Global Warming Potential (GWP) refrigerants. NEEA recommends consulting with the Environmental Protection Agency (EPA) and applicable local, state, and regional organizations for current recommendations on which refrigerants will be allowed for national and state agencies.

Appendix H: Commercial System COP Measurement and Verification Requirements

The coefficient of performance (COP) represents performance of heating equipment and is determined by calculating the ratio of the useful heating energy output by the electrical energy input. When all the heat output and energy inputs for a water heating system are measured, this ratio is called the System Coefficient of Performance (SysCOP). This appendix defines the minimum requirements for a Measurement and Verification (M&V) system to monitor SysCOP when it is required. Instrumentation needed to field monitor and calculate SysCOP is described for each system configuration outlined in Section 3.3.5, Figure 2 through Figure 8.

The SysCOP represents the performance of the entire water heating system, can be used to estimate annual energy and greenhouse gas (GHG) emissions savings, and is used to rate commercial products on the Qualified Products List. In addition to instrumentation needed to monitor SysCOP, instrumentation needed to monitor equipment COP (ECOP), primary COP (PCOP), and temperature maintenance COP (TMCOP) are described. Definitions of all COPs are included in the Glossary.

When required by utility programs, instrumentation to validate field SysCOP shall be installed per this Appendix based on system configuration and desired measurement method (boundary method, equipment method, and/or primary equipment method). The M&V system is intended to calculate and report the heat pump water heating SysCOP and should meet the following requirements:

1. Minimum requirements for sensors and meters:
 - a. Temperature Sensors: $\pm 1.0^{\circ}\text{F}$ tolerance
 - i. Temperature sensors may be direct immersion, placed in thermowells, or strapped to pipe under insulation. Temperature sensors in thermowells and strapped to pipe must be installed using thermal paste to increase conductivity and minimize errors.
 - ii. Temperature sensor used to record ambient conditions (shown as T4) must be installed in the space from which the HPWH pulls air – outdoors or in a buffer space. If the HPWH is installed outdoors, National Oceanic and Atmospheric Administration (NOAA) data may be used instead of a temperature sensor. Temperature sensors shall not be exposed to direct sunlight.
 - b. Flow rate sensors/water meters: $\pm 3\%$ accuracy at minimum and maximum flow rates.
 - i. BTU meters may be used in place of a flow meter and two temperature sensors where appropriate, if accuracy of temperature sensors and flow sensor comply with accuracy requirements and temperatures and flows are logged separately. BTU meters shall not be configured to log energy; they shall be configured to log flow, and two temperatures.

- c. Current transducers and/or power meters: $\pm 1\%$ accuracy, equipment amperage must not be less than 10% of current transducer rating.
 - i. Current transducers are required on all equipment outlined in the “Power Input” equation below²⁰ for current measurement except for electric resistance equipment where ON/OFF states are tracked, which may be estimated as outlined below under #2. However, using CTs instead of assuming power is recommended whenever possible.
 - ii. Power may be calculated from current using standard line voltage and power factor of 1, or a power meter may be used to measure voltage with current transducers to account for power factors less than 1.²¹
 - iii. Multiple components may be grouped on a single set of current transducers or power meter.
2. Energy usage may be estimated, and equipment COP may be assumed for electric resistance (ER) equipment:
 - a. An ECOP of 0.95 shall be assumed for ER that is not monitored with current transducers.
 - b. When assuming ER equipment power draw, actual power must be spot checked and recorded at startup. A minimum of three spot checks must be performed. The average of the three-spot check shall be compared to product specifications to ensure accuracy and used in calculations.
 - i. Energy usage may be calculated for non-modulating ER equipment by tracking runtime and assuming the rated power draw over the runtime.²²
 - ii. Energy usage may be calculated for modulating tankless electric resistance using inlet temperature, outlet or setpoint temperature,²³ and flow, assuming a COP of 0.95. If the flow is constant and measured during startup, constant flow may be assumed. Estimated power shall not exceed rated power output of equipment by more than 2%.
3. Data shall be logged at one-minute intervals.
4. SysCOP shall be calculated daily.
5. Data shall be logged and stored for access for a minimum duration of six months.
6. Project details shall be recorded, including:
 - a. Project location: Zip Code
 - b. Occupancy demographics: building type, occupancy class, number of apartment units, number of full-time occupants
 - c. System equipment specifics (i.e., system configuration – per Section 3.3.5 of this document, number of heat pumps, heating capacity of each heat pump, swing tank heating capacity, swing tank volume, volume of primary storage)

²⁰ Recirculation pumps typically draw less than 200W and may be excluded.

²¹ If actual power factor is less than 1, assuming a power factor of 1 will increase calculated power draw and decrease calculated system COP. A power meter is recommended to account for decreases in COP from power factor.

²² Energy usage and heating capacity may decrease over time with scale build-up, which may decrease calculated system COP. A power meter is recommended to account for decreases in COP from scale.

²³ If a tankless electric water heater does not achieve setpoint temperature, assuming outlet water temperature is equal to setpoint temperature may increase calculated energy use and decrease calculated system COP. Measure leaving water temperature to account for decreases in COP from setpoint deviation.

The following diagram illustrates the various coefficient of performance boundaries for a single-pass HPWH system with a parallel temperature maintenance tank. The energy inputs to power the hot water circulation pump(s) and thermostatic mixing valve(s), when present, are not included in the SysCOP calculations but the equipment is shown below for illustrative purposes.

Figure 14. Coefficient of Performance (COP) Boundaries

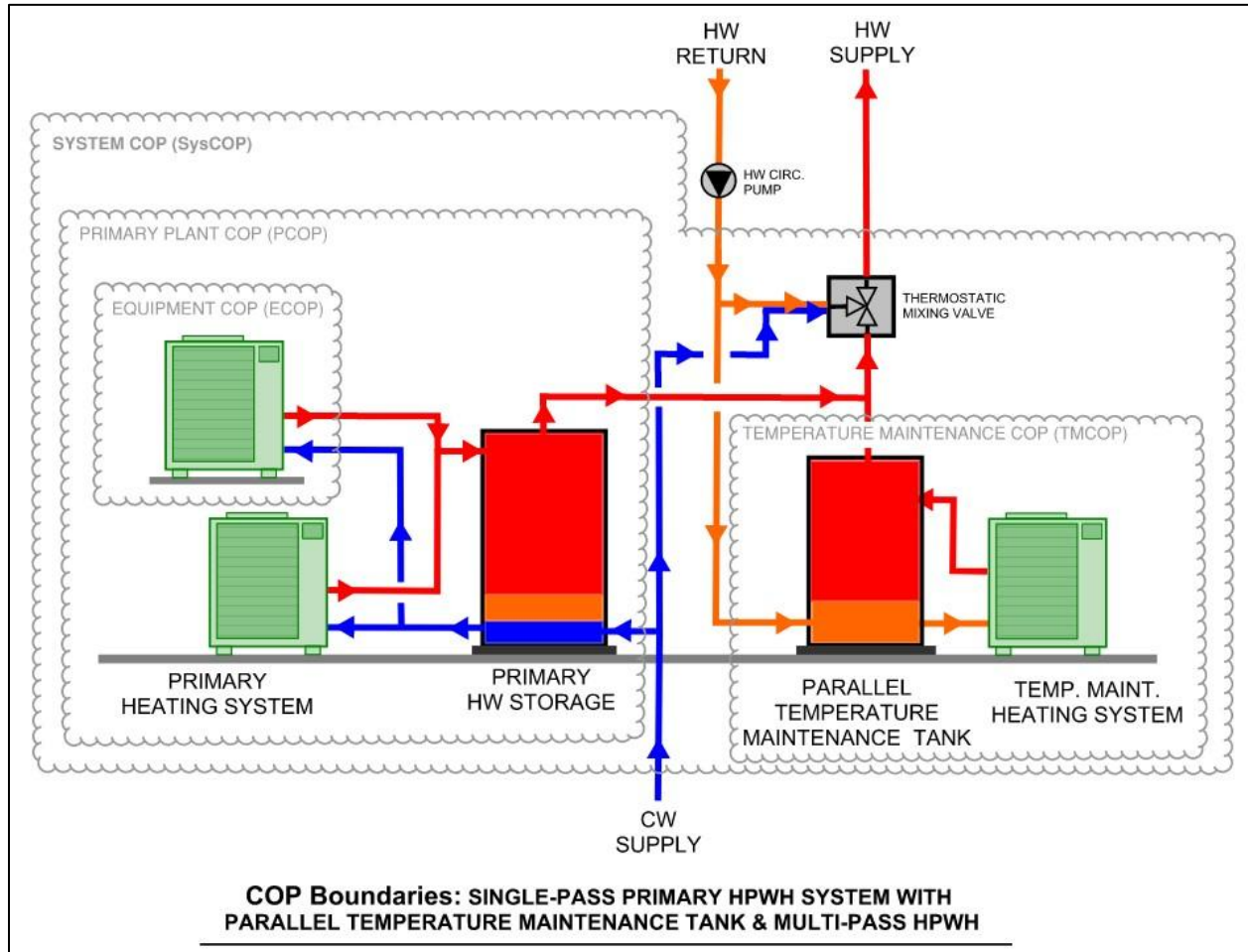

Methods for Installing M&V Instrumentation to Measure SysCOP

Three main methods exist for installing measurement and verification (M&V) instrumentation to measure SysCOP. These methods, defined below, are referred to as the Boundary Method, Equipment Method, and Primary Equipment Method.

Boundary Method

The Boundary Method sums the heat introduced into the supply water by both the primary plant and the temperature maintenance system and divides the sum by the total electrical energy input for associated equipment (heat pumps and electric resistance heating elements):

$$\text{SysCOP} = \frac{\text{Heating}_{\text{Primary}} + \text{Heating}_{\text{Temp. Maintenance}}}{\text{Power Input}}$$

Where...

$$\text{Heating}_{\text{Primary}} = m_{\text{cold water}} * c_p * (T_{\text{loop_supply}} - T_{\text{cold water}}),$$

$m_{\text{cold water}}$ = mass flowrate of cold water entering system,

c_p = specific heat of water,

$$\text{Heating}_{\text{Temp. Maintenance}} = m_{\text{recirc}} * c_p * (T_{\text{loop_supply}} - T_{\text{loop_return}}),$$

m_{recirc} = mass flowrate of recirculation loop,

AND

$$\text{Power Input} = \text{HPWH}_{\text{Power}} + \text{ER_Heat}_{\text{Power}} + \text{Fan}_{\text{Power}} + \text{AuxHeat}_{\text{Power}} + \text{HeatTrace}_{\text{Power}}$$

$\text{HPWH}_{\text{Power}}$ = Electrical power used by HPWHs

$\text{ER_Heat}_{\text{Power}}$ = Electrical power used by electric resistance water heating equipment

$\text{Fan}_{\text{Power}}$ = Electrical power used by auxiliary fans when HPWHs are installed indoors

$\text{AuxHeat}_{\text{Power}}$ = Electrical power used by space heating equipment which provide heat to HPWHs

$\text{HeatTrace}_{\text{Power}}$ = Electrical power used by heat trace freeze protection systems

Figure 15 identifies the power meters, flow meters, and temperature sensors required to calculate SysCOP using the Boundary Method.

Figure 15. Boundary Method – Required Instrumentation

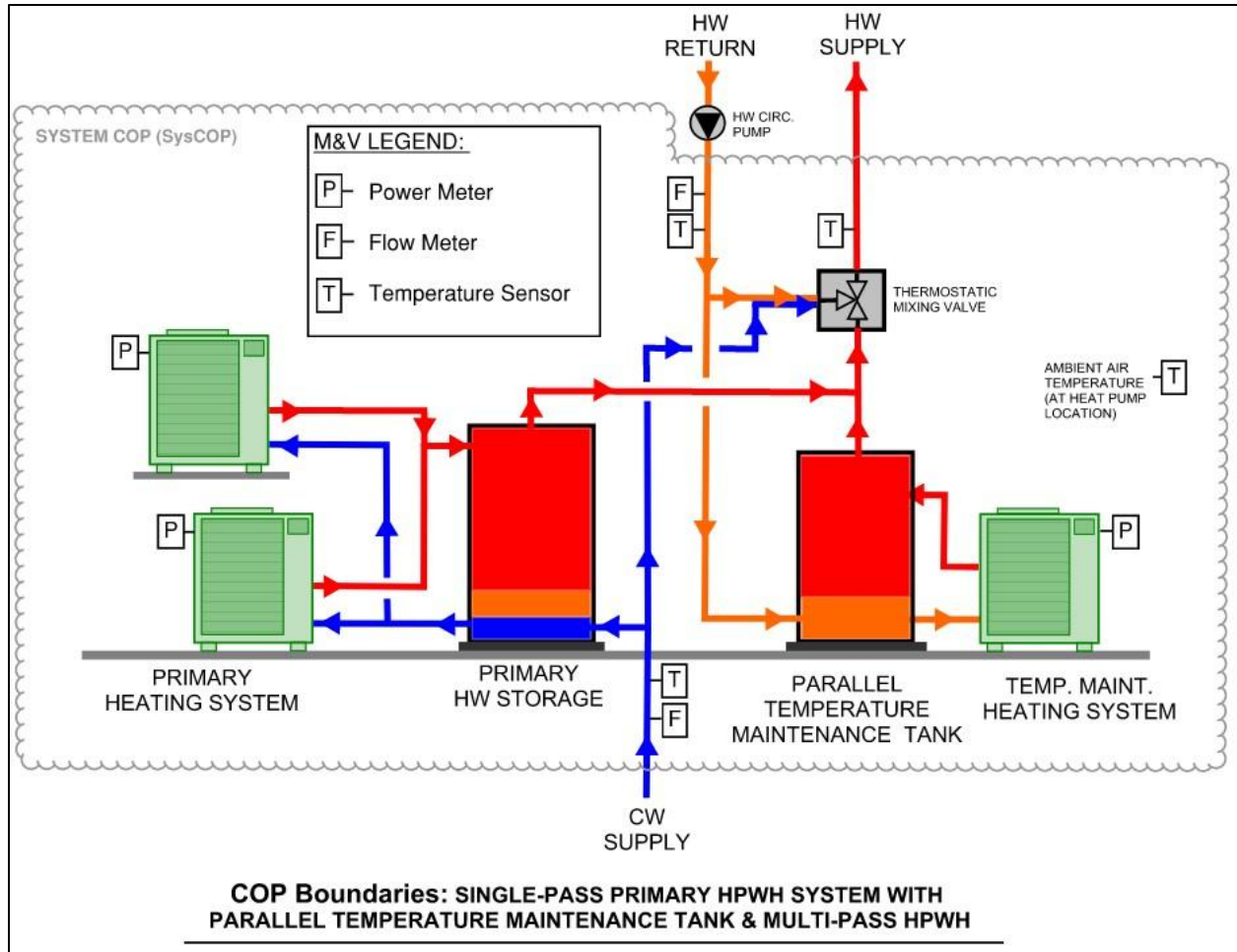

Equipment Method

A second method of calculating SysCOP consists of measuring equipment COP for each piece of electricity-consuming equipment. This method, labeled the Equipment Method, can yield a different value for SysCOP than the Boundary Method in that it does not always account for heat losses from the primary storage tanks. However, a variation on the Equipment Method that includes heat losses from primary storage, referred to as the Primary Equipment Method, is also identified below.

The Equipment Method sums the heat introduced into the system by each piece of equipment (as opposed to heat introduced by each system) and divides the sum by the total electrical energy input for associated equipment (heat pumps and electric resistance heating elements):

$$\mathit{SysCOP} = \mathit{COP}_{\mathit{eqp.1}} * \frac{\mathit{Energy Usage}_{\mathit{eqp.1}}}{\mathit{Total Energy Usage}} + \mathit{COP}_{\mathit{eqp.2}} * \frac{\mathit{Energy Usage}_{\mathit{eqp.2}}}{\mathit{Total Energy Usage}} + \dots$$

OR

$$\mathit{SysCOP} = \frac{\mathit{Heating}_{\mathit{eqp.1}} + \mathit{Heating}_{\mathit{eqp.2}} + \dots + \mathit{Heating}_{\mathit{eqp.n}}}{\mathit{Total Energy Usage}}$$

Where the heat added to system for any piece of equipment (eqp_n) is equal to:

$$\mathit{Heating}_{\mathit{eqp.n}} = m_{\mathit{eqp.n}} * c_p * (T_{\mathit{outlet_eqp.n}} - T_{\mathit{inlet_eqp.n}})$$

AND

$$m_{\mathit{eqp.n}} = \text{mass flowrate of water through equipment}$$

Figure 16 identifies the power meters, flow meters, and temperature sensors required to calculate SysCOP using the Equipment Method. Note that the method shown in Figure 16 does not account for heat losses from the primary storage tanks.

Figure 16. Equipment Method – Required Instrumentation (parallel temperature maintenance configuration, excludes primary storage heat losses)

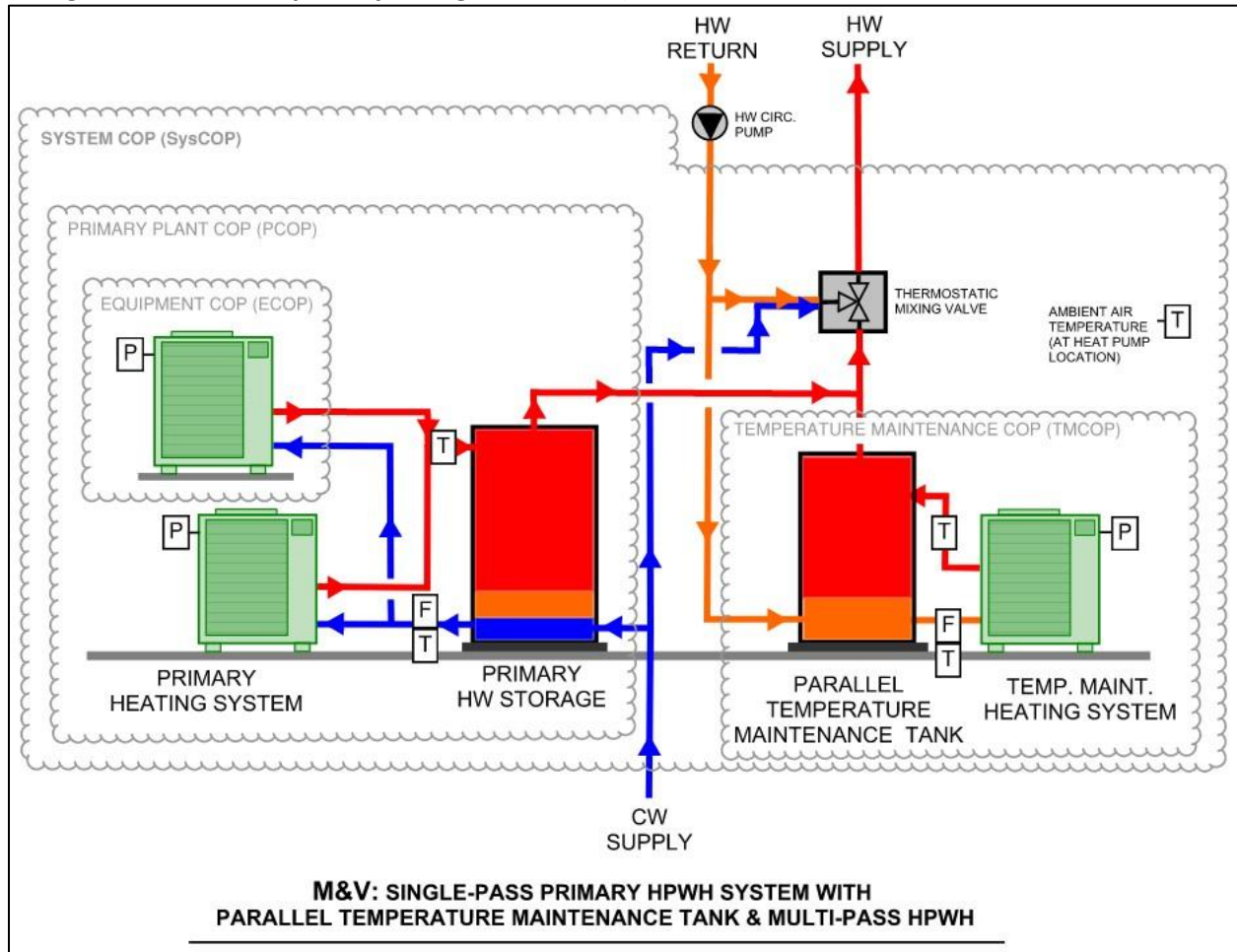

Alternatively, for systems using a swing tank for temperature maintenance (as shown in Figure 17), the COP of the temperature maintenance system may be assumed (the COP of an electric resistance water heater approaches 0.95):

$$SysCOP = COP_{primary} * \frac{Energy\ Usage_{primary}}{Total\ Energy\ Usage} + COP_{TM} * \frac{Energy\ Usage_{Temp.\ Maintenance}}{Total\ Energy\ Usage}$$

Using the assumed COP for the temperature maintenance system allows deletion of flow and temperature instrumentation on the swing tank as shown in Figure 17:

Figure 17. Equipment Method – Required Instrumentation (swing tank configuration)

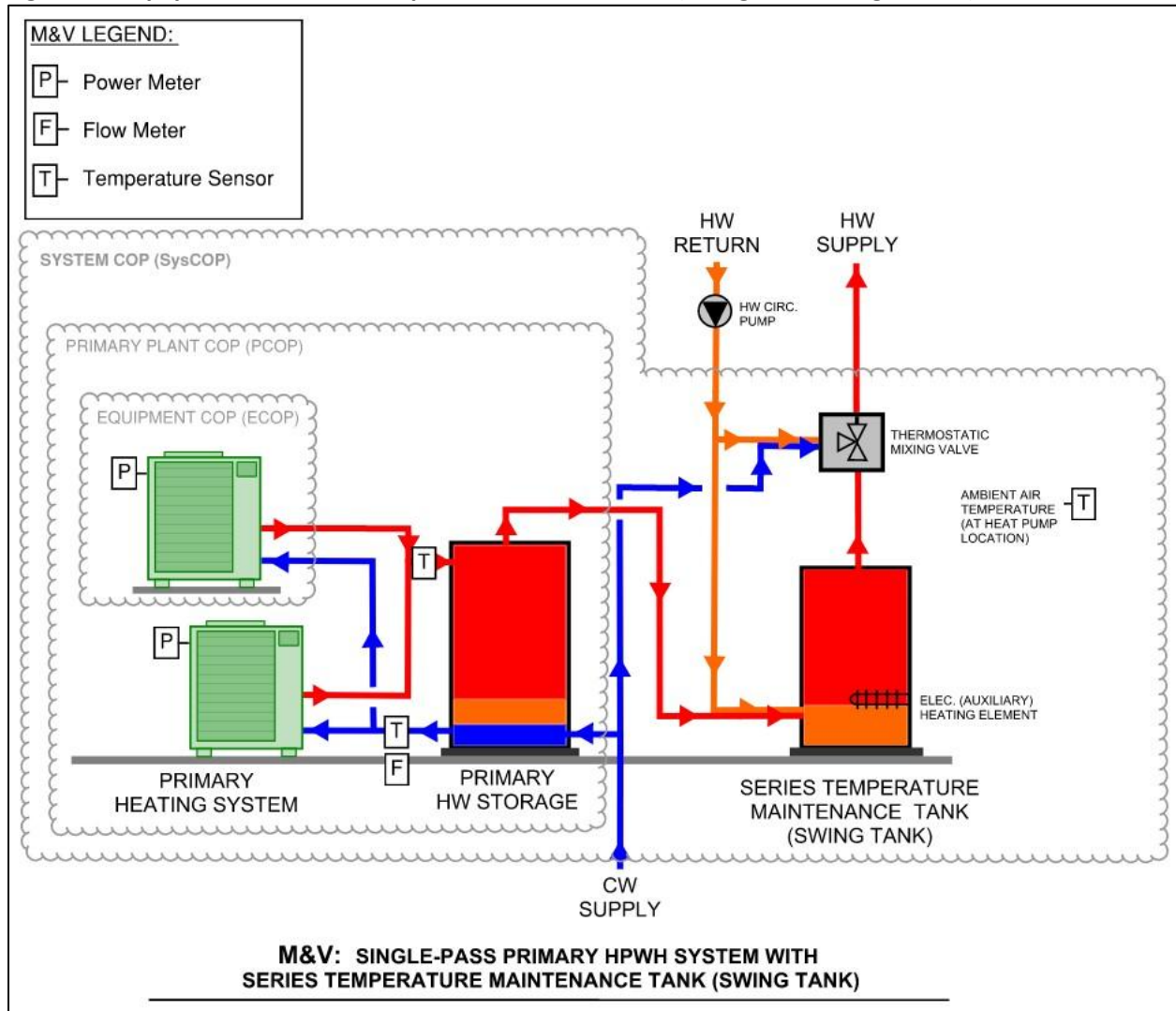

Primary Equipment Method

A third method of calculating SysCOP is a variation on the Equipment Method that includes heat losses from the storage tanks. In this method, the calculation methodology is the same as that of the Equipment Method. However, flow and temperature sensors are installed such that the primary storage tanks are included in the boundary.

Figure 18 identifies the power meters, flow meters, and temperature sensors required to calculate SysCOP using the Primary Equipment Method.

Figure 18. Primary Equipment Method – Required Instrumentation (parallel temperature maintenance configuration – includes primary storage heat losses)

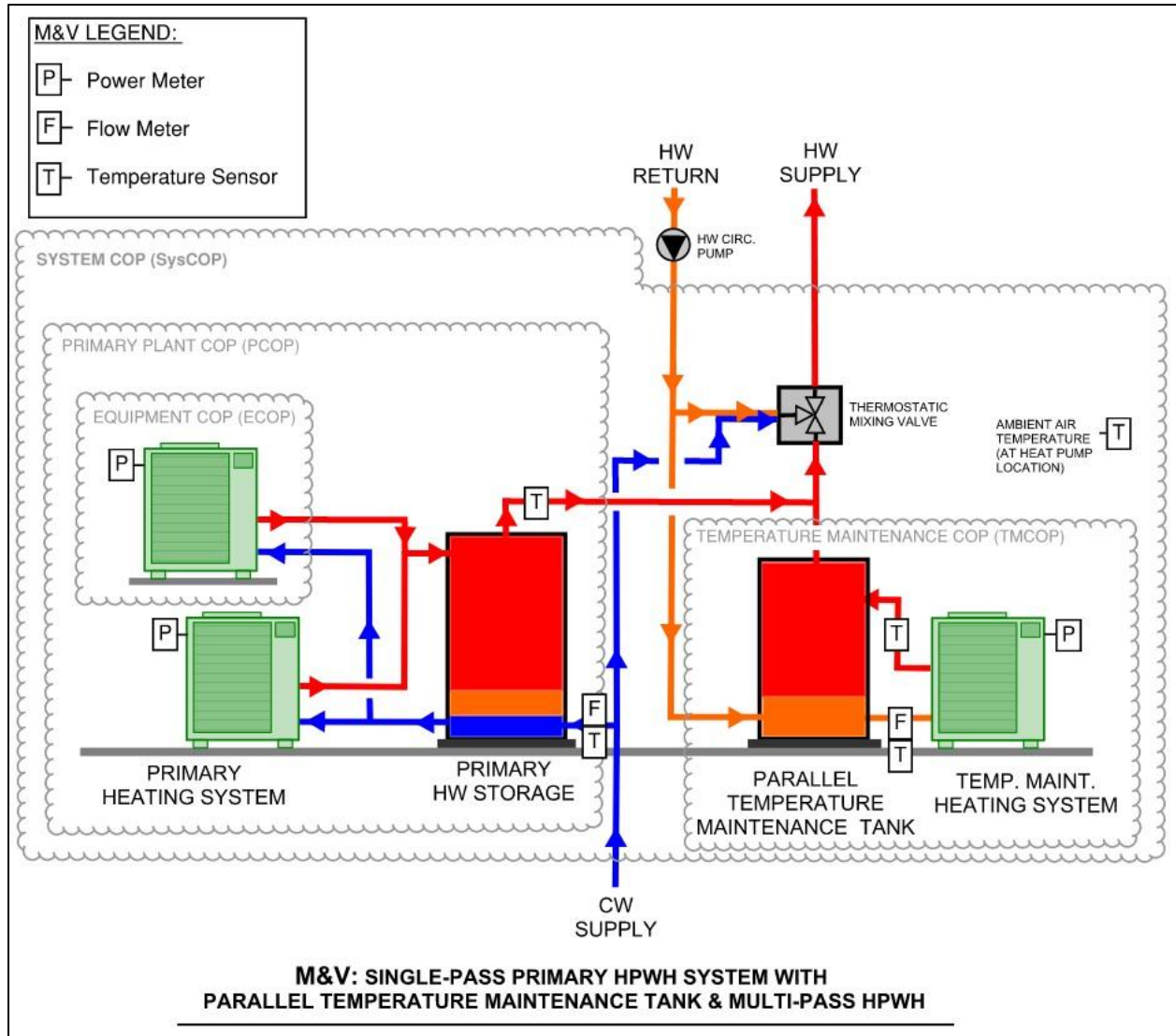
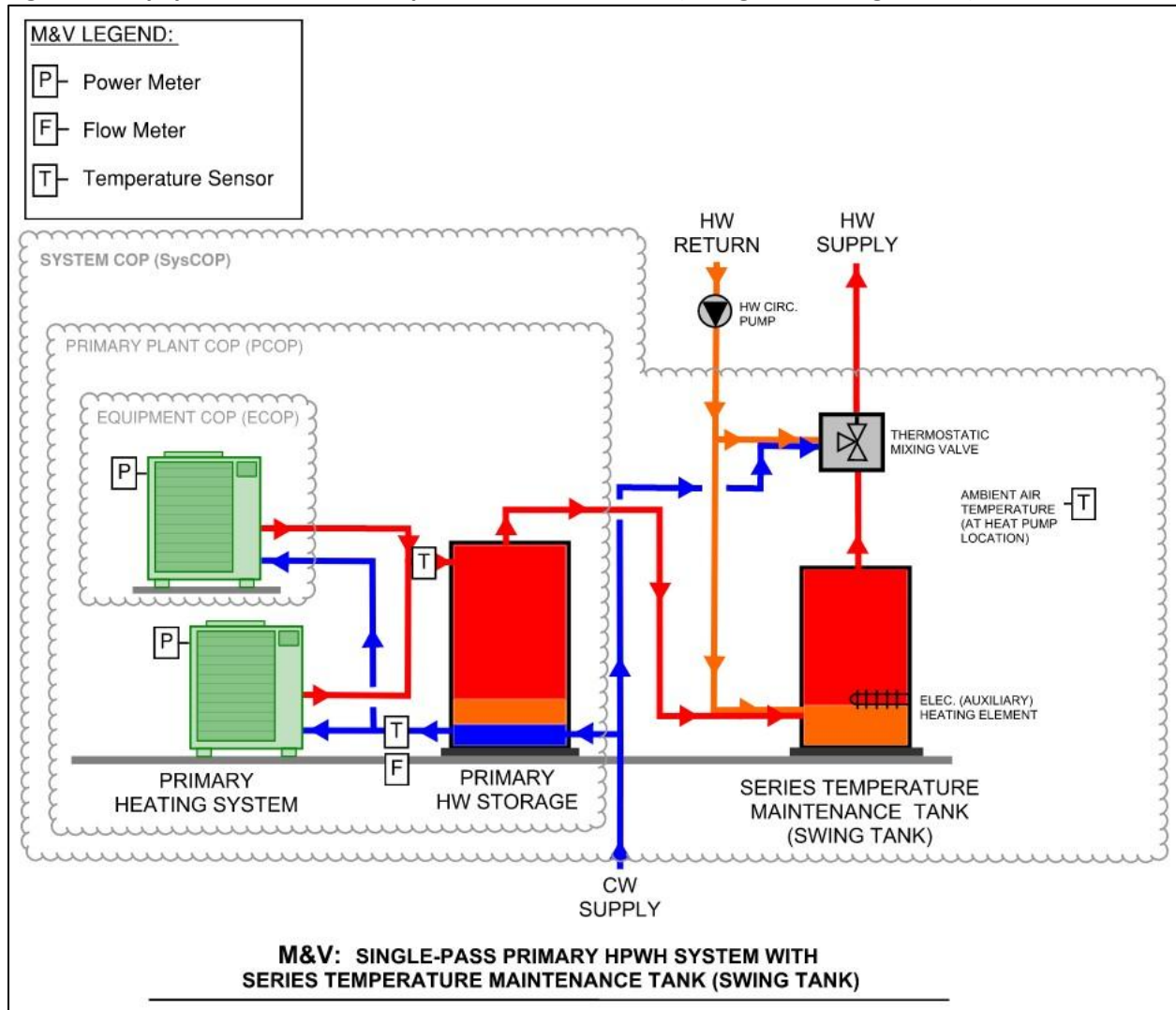

Figure 19. Equipment Method – Required Instrumentation (swing tank configuration)



Equipment Method Correction Factor (Derate)

Since instrumentation installed in accordance with the Equipment Method does not account for heat losses from the storage tanks, SysCOP measurements using that method will be artificially inflated. When using the Equipment Method, a SysCOP derate shall be applied per Table 18. Any SysCOP values calculated using the Equipment Method shall be multiplied by the appropriate derate factor from the table.

**Table 18. Equipment Method
SysCOP Calculation Derate**

Equipment Method SysCOP Derates	
Primary Storage Insulation (R-Value)	Derate (%)
R-12 – R-16	12
R-16 – R-20	10
R-20 – R-24	8
R-24 – R-28	6
R-28 – R-32	4
>R-32	2

Required M&V Instrumentation Based on CHPWH System Configuration

The following figures show the minimum instrumentation required to calculate SysCOP using the Boundary, Equipment, and Primary Equipment methods for various HPWH configurations:

- Single-Pass Primary HPWH without Recirculation
- Single-Pass Returned to Primary
- Single-Pass Swing Tank
- Single-Pass Parallel Loop Tank
- Integrated HPWH without Recirculation
- Integrated HPWH Returned to Primary
- Multi-Pass Returned to Primary

Additional instrumentation required to inform calculations using the Equipment Method is also noted. Note that only qualified piping configurations, in accordance with Section 3.3.5 of this document, are shown.

In the following diagrams, temperature sensors used for equipment control are shown as a “T” enclosed in a circle; these sensors are typically shown within the storage and swing tanks. These sensors are not required as part of the M&V package, though they are required for equipment control; when possible, these sensors shall be monitored similarly to the M&V equipment package.

Single-Pass Primary HPWH without Recirculation

Figure 20 shows required M&V instrumentation for a single-pass HPWH with no recirculation loop:

Figure 20. Single-Pass Primary HPWH without Recirculation

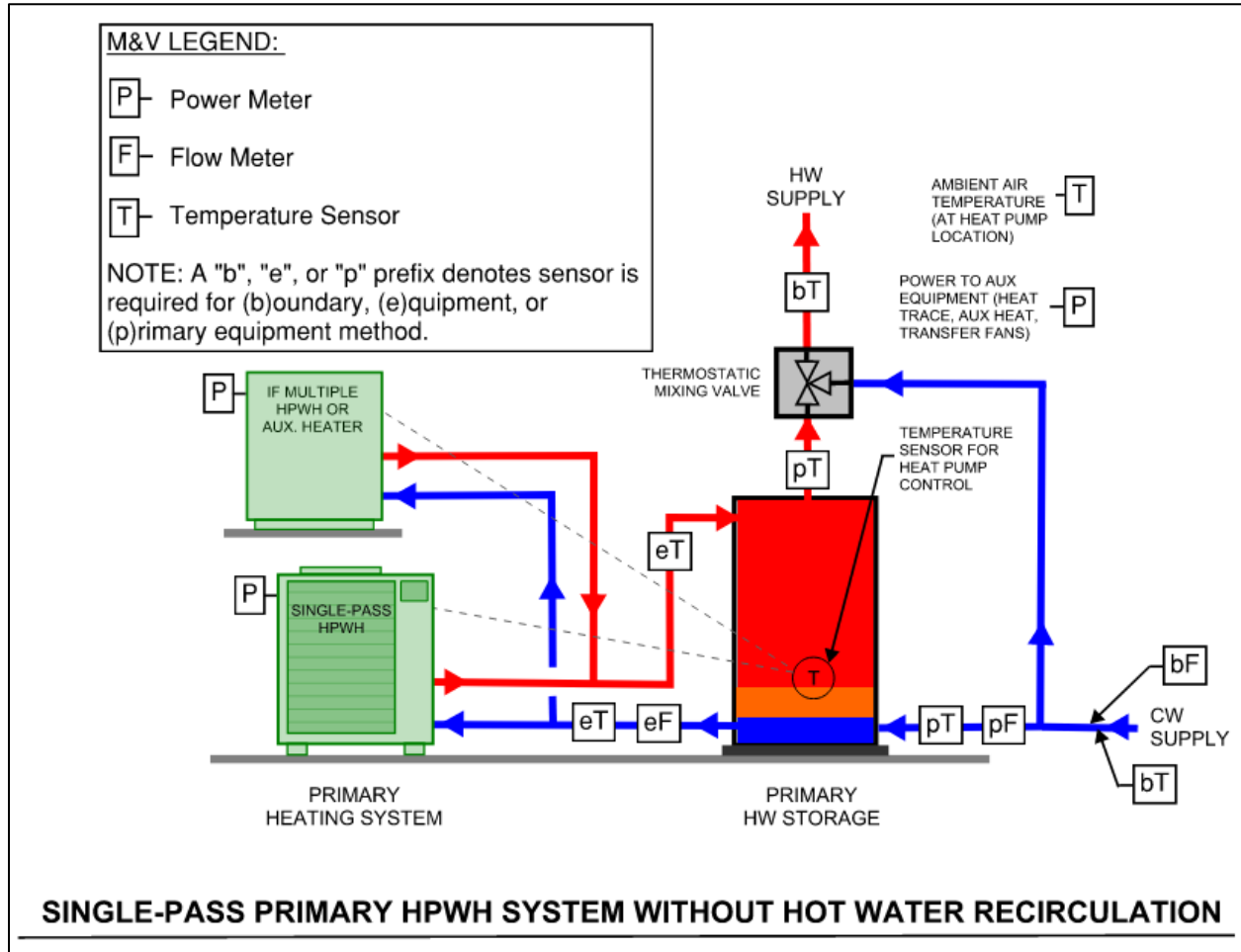

Single-Pass Returned to Primary

Figure 21 shows required M&V instrumentation for a single-pass HPWH in returned-to-primary configuration:

Figure 21. Single-Pass Returned to Primary

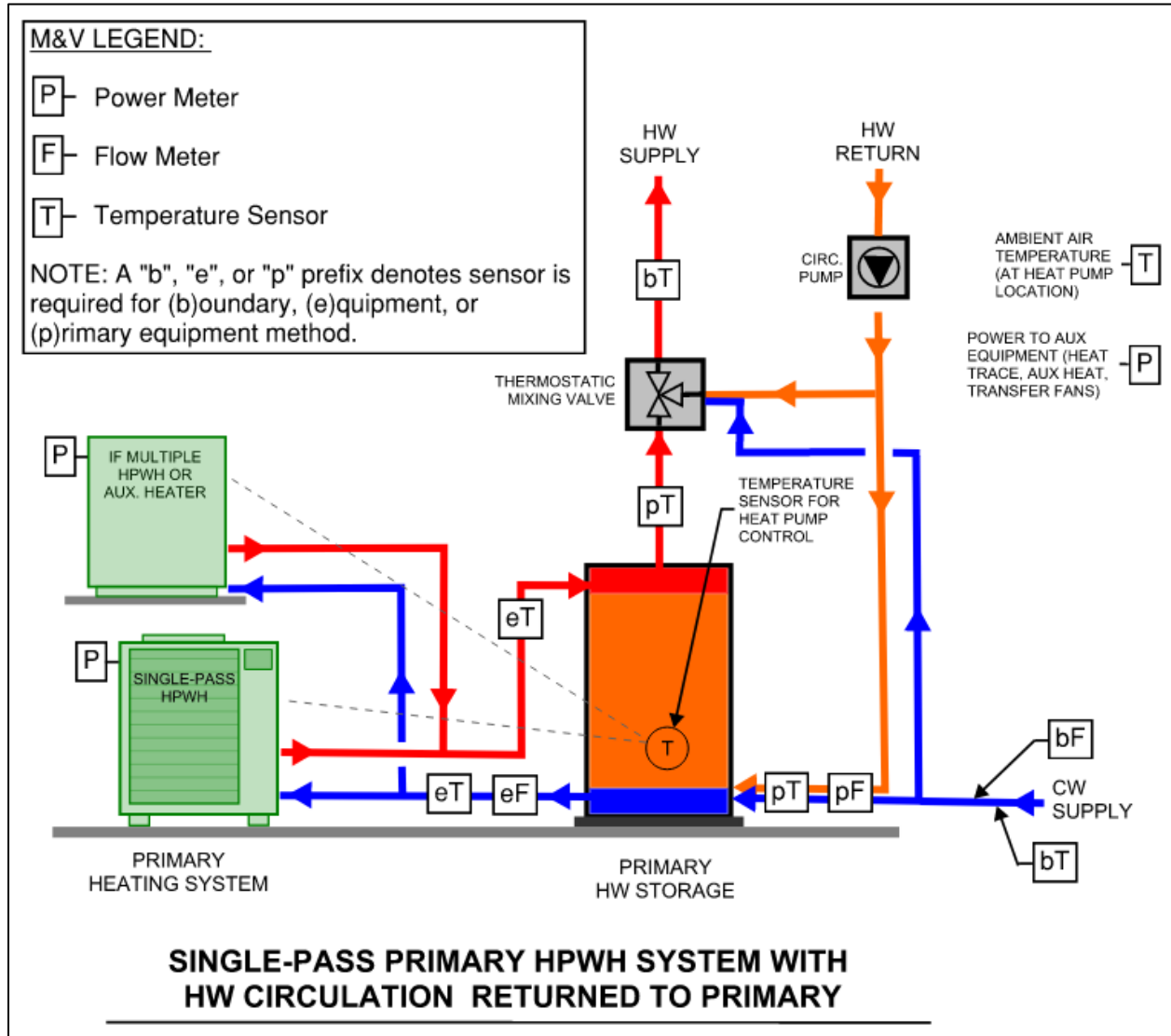

Single-Pass Swing Tank

Figure 22 shows required M&V instrumentation for a single-pass swing tank configuration:

Figure 22. Single-Pass Swing Tank

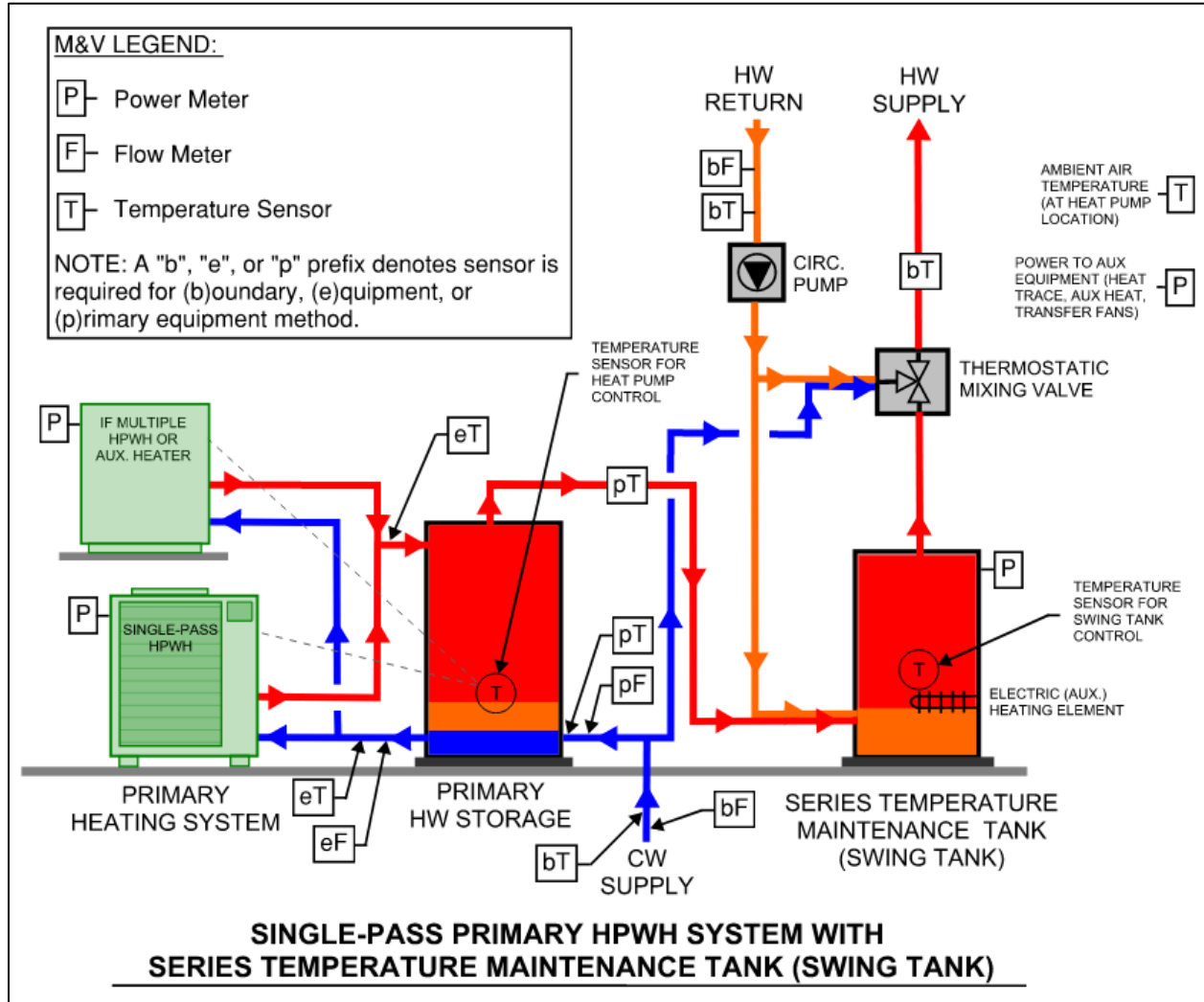

Single-Pass Parallel Loop Tank

Figure 23 shows required M&V instrumentation for a single-pass parallel loop tank configuration:

Figure 23. Single-Pass Parallel Loop Tank

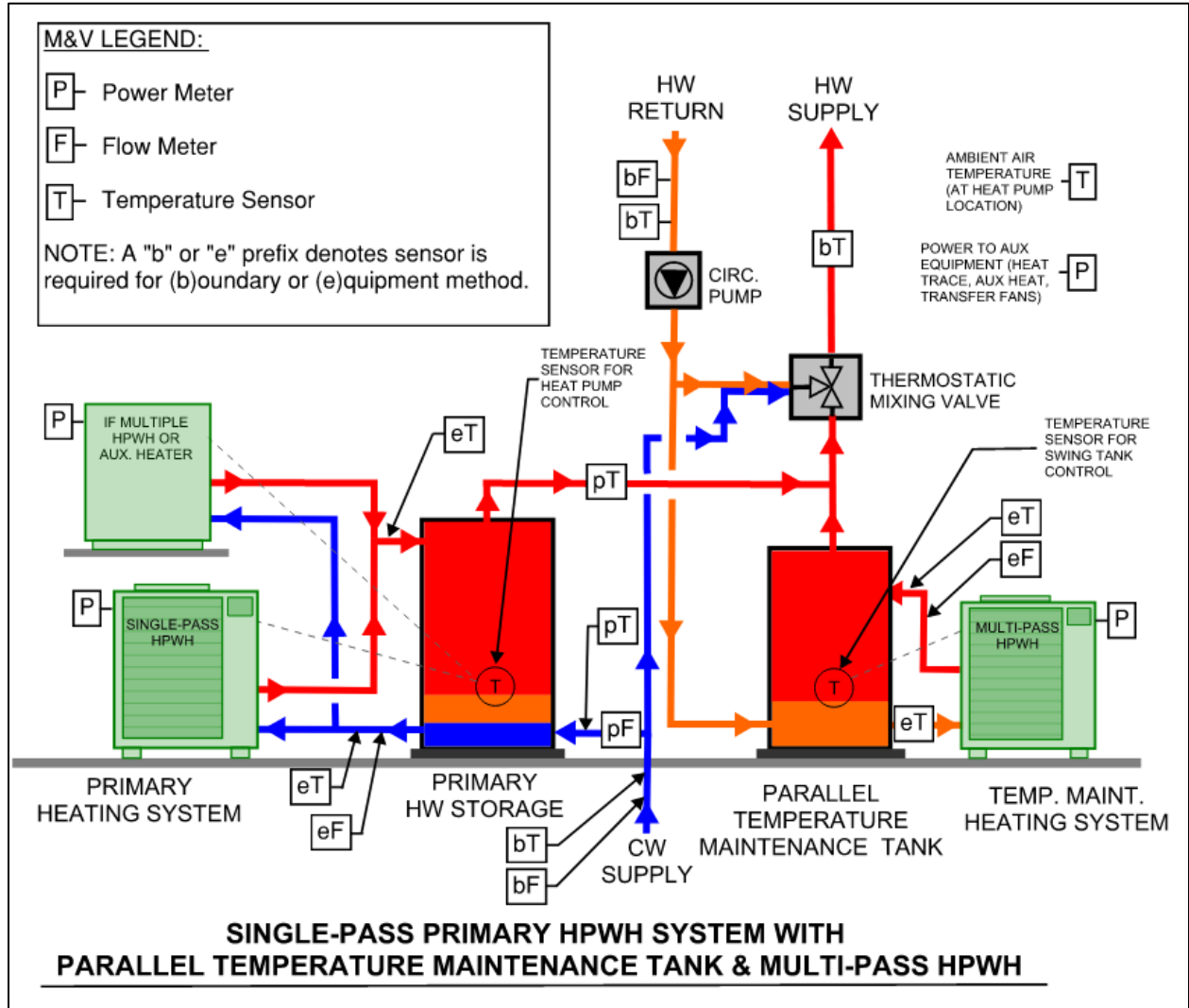

Integrated HPWH without Recirculation

Figure 24 shows required M&V instrumentation for an integrated CWPWH without recirculation configuration:

Figure 24. Integrated HPWH without Recirculation

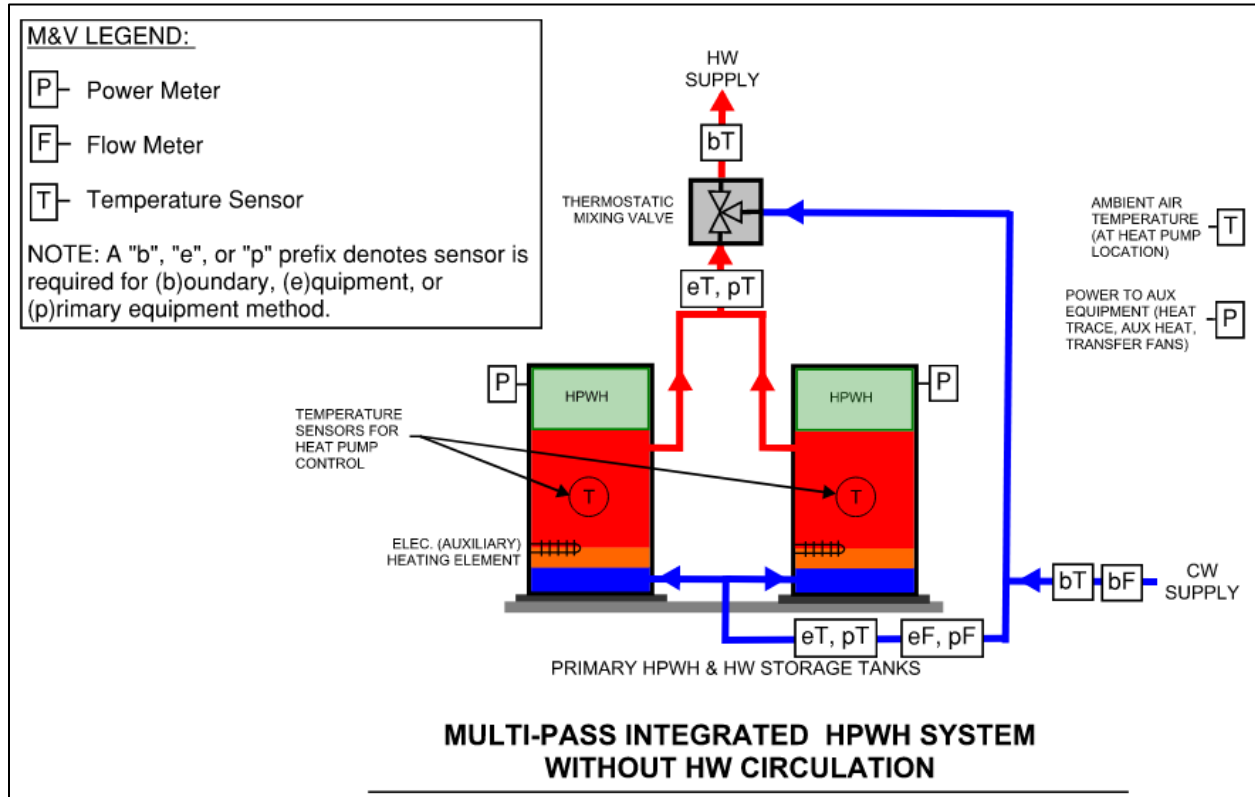

Integrated HPWH Returned to Primary

Figure 25 shows required M&V instrumentation for an integrated CHPWH in a returned-to-primary configuration:

Figure 25. Integrated HPWH Returned to Primary

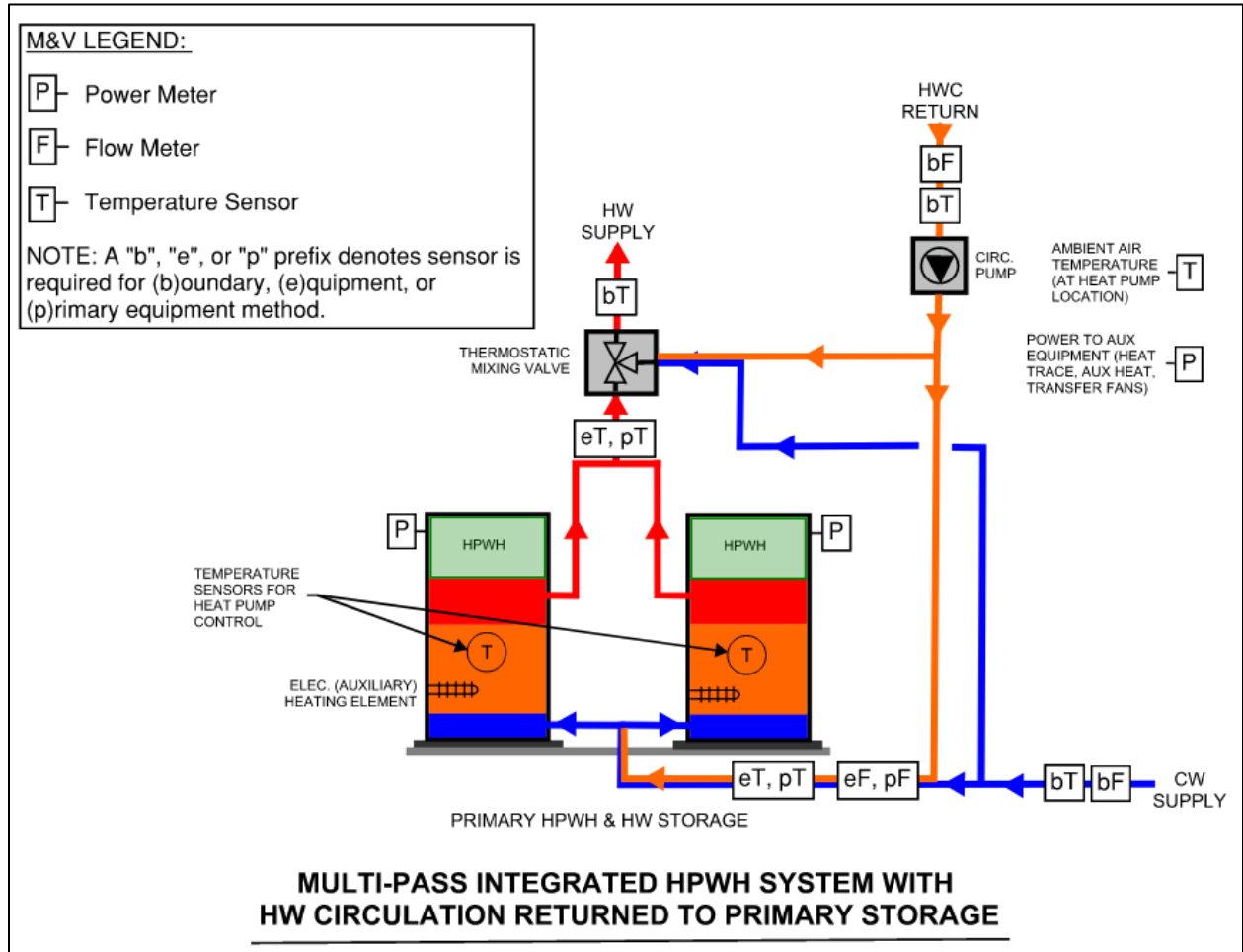

Multi-Pass Returned to Primary

Figure 26 shows required M&V instrumentation for a multi-pass returned-to-primary configuration:

Figure 26. Multi-Pass HPWH Returned to Primary

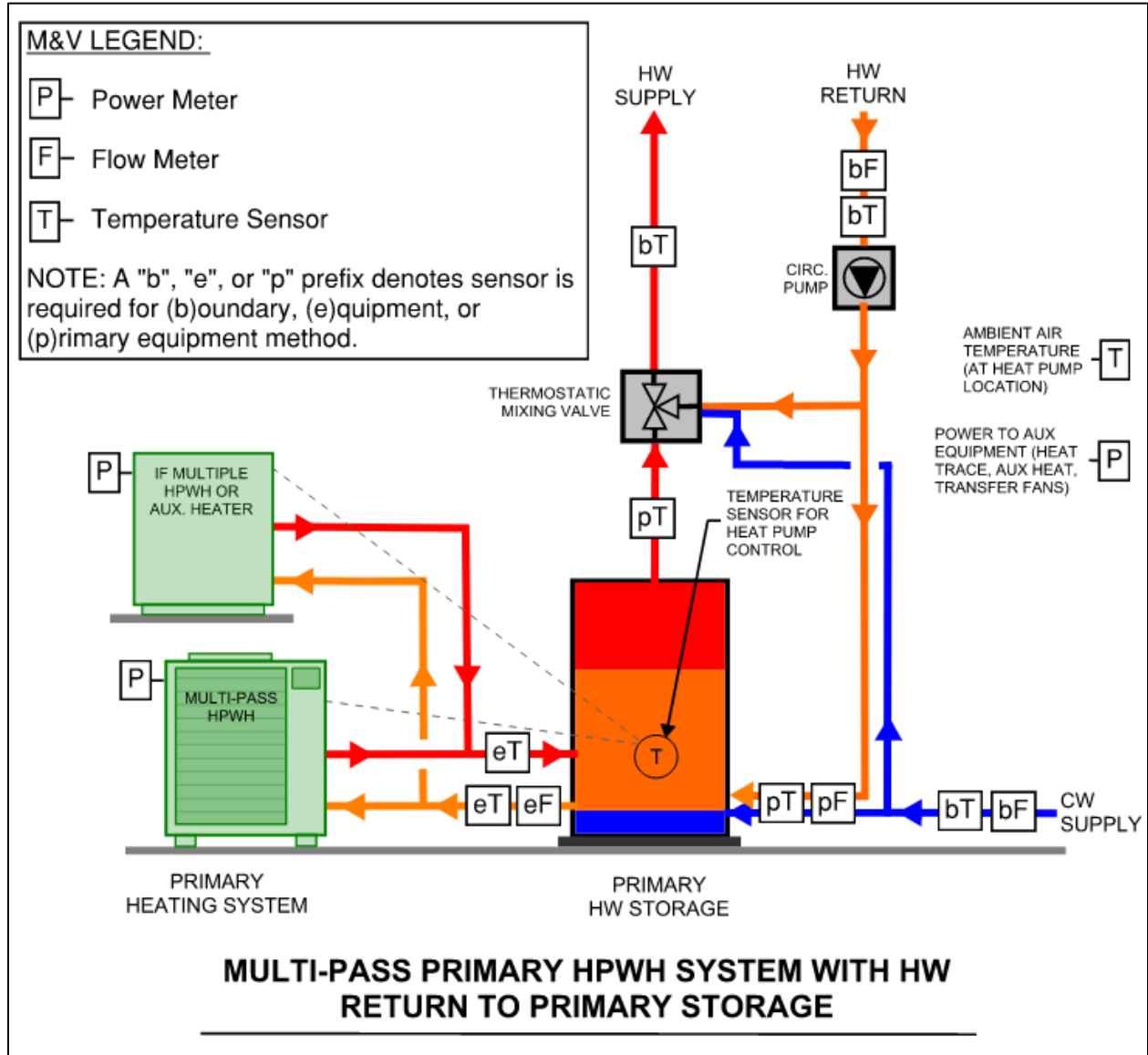

Appendix I: Product Assessment Datasheet (PADS) Document

Manufacturers can access the Product Assessment Datasheets (PADS) at <https://neea.org/our-work/advanced-water-heater-specification>.

Appendix J: Commercial Integrated Performance Map Test Procedure

Appendix F describes a calculation that uses performance map data provided through testing or simulation of CHPWHs to predict SysCOP for listing on the QPL. The performance map, shown in Figure 27 below, describes the equipment COP (ECOP) at various OAT and IWT and aligns with performance maps given by the ENERGY STAR Final Test Method for Central Heat Pump Water Heater Systems. While the ENERGY STAR test method is not inclusive of integrated products, aligning test conditions for all commercial products within the AWHs reduces complexity.

Figure 27. Performance map for an integrated unit

Primary HPWH Performance Data							
	DB, °F	WB, °F	Inlet Water Temperature	Tank Setpoint Temperature	Input Power, kW	Output Heat, kW	COP
Lowest Temperature*	0	-1	68	140			1.0
A	5	4	68	140			1.0
B	17	15	69	140			1.0
C	35	33	72	140			1.0
D	47	43	74	140			1.0
E	68	57	78	140			1.0
F	95	75	87	140			1.0

*Energy Star test procedure uses 5F as the lowest test temperature, however manufacturers may input lower values if data is available.
Electric resistance heating is assumed below "Lowest Temperature" input above.

Simulating and testing equipment performance maps for split system products is straightforward. Inlet temperature, outlet temperature, and flow through the HPWH are used to determine output power. However, because thermal storage and heat pump are packaged together in integrated products, testing for performance data is less straightforward. This appendix provides a preliminary test procedure for testing integrated products to provide performance data for inclusion in the commercial QPL.

Test Conditions

Integrated products shall be installed as shown in section 3.3.5 figure 7 with a mixing valve (set to 125°F supply) for testing unless the product includes non-potable storage, heat exchanger to potable water, and means of targeting a supply water temperature to provide instantaneous heating of potable water. Integrated units with potable water storage shall use the same test conditions as single pass return to primary with a tank setpoint of 140°F. Integrated units with separate, non-potable storage, and instantaneous potable water heating may use a target 125°F outlet water temperature instead of a 140°F tank setpoint temperature during testing.

First Hour Rating and Draw Pattern

To determine the tested draw pattern, the integrated unit is tested per DOE 10 CFR Appendix E to Subpart B of Part 430; 5.3.3 First-Hour Rating Test²⁴.

The draw pattern used in testing is based on the First-Hour Rating (FHR) and shown in the table below. The draw pattern is based on the first draw cluster in Table III.4—High-Usage Draw Pattern from DOE 10 CFR Appendix E to Subpart B of Part 430 and scaled to commercial products using the First Hour Rating. Vendors may round to the nearest gallon and tenth of a GPM when testing.

Table 19. Draw Pattern for Integrated CHPWHs

Draw Pattern			
Draw	Time during test [hh:mm]	Volume [gallons]	Flow rate [GPM]
#1	0:00	0.36 * FHR	0.04 * FHR
#2	0:30	0.03 * FHR	0.015 * FHR
#3	0:40	0.01 * FHR	0.015 * FHR
#4	1:10	0.12 * FHR	0.025 * FHR
#5	1:30	until cut-in ²⁵	1.0

Test Procedure

To perform performance map testing, the vendor shall perform the draw profile test for each set of conditions in the performance map. When performing the draw profile test the vendor shall:

1. Establish normal water heater operation: if the water heater is not operating, initiate a draw. Terminate that draw when equipment cut-in occurs.
2. Allow to operate until tank is fully charged, compressor and electric resistance elements turn off (cut out) before starting the test. Start the test within 5 minutes of cut-out.
3. **Start of Test:** Start monitoring electrical usage, flow, inlet/outlet water temperature, and ambient conditions (at a minimum dry bulb, but wet bulb is also encouraged) in the test chamber and initiate the draw pattern draws #1 through #4.
4. If the equipment cut-in does not occur within 5 minutes of the completion of draw pattern #4, draw water at the rate of draw #5 until cut-in occurs. Stop draw when equipment cut-in occurs.
5. After the draw pattern is completed, allow integrated unit to continue to operate until it again reaches a fully charged state.
6. **End of Test:** All electrical usage, flow, inlet/outlet water temperature, and ambient conditions between the first and second fully charged states shall be submitted to NEEA at each performance map condition.

Vendor shall follow all test setup and tolerance requirements outlined DOE 10 CFR Appendix E to Subpart B of Part 430.

²⁴ Note that the DOE test is performed without a mixing valve. This test shall be performed with a mixing valve but the First Hour Rating calculated without a mixing valve per the DOE test procedure shall be used to calculate the draw pattern outlined in Table 19.

²⁵ Draw #5 is only required, per test step 4 if cut-in does not occur at the completion of draw #4. The volume draw of draw #5 depends on the time needed to induce a cut-in.