

# Laboratory Assessment of Sanden GAU Heat Pump Water Heater Lab

18 September 2013



A Report of BPA Technology Innovation Project #292

Prepared for  
Ken Eklund, Project Principal Investigator  
Washington State University Energy Program  
Under Contract to  
Kacie Bedney, Project Manager  
Bonneville Power Administration

Prepared by  
Ben Larson  
Ecotope, Inc.



## A Technology Innovation Project Report

The study described in the following report was funded by the Washington State University Energy Program under contract to Bonneville Power Administration (BPA) to provide an assessment of the state of technology development and the potential for emerging technologies to increase the efficiency of electricity use. BPA is undertaking a multi-year effort to identify, assess, and develop emerging technologies with significant potential for contributing to efficient use of electric power resources in the Northwest.

Neither WSU nor BPA endorse specific products or manufacturers. Any mention of a particular product or manufacturer should not be construed as an implied endorsement. The information, statements, representations, graphs, and data presented in these reports are provided as a public service. For more reports and background on BPA's efforts to "fill the pipeline" with emerging, energy-efficient technologies, visit Energy Efficiency's Emerging Technology (E3T) website at [http://www.bpa.gov/energy/n/emerging\\_technology/](http://www.bpa.gov/energy/n/emerging_technology/).

Ben Larson is a senior analyst and research scientist at Ecotope. He has a multifaceted background in physics, experimental design, numerical modeling, climate change, and energy efficiency. Among his work at Ecotope is a key role maintaining and developing the SEEM energy simulation program, which is used to model energy efficiency improvements in the residential sector. Mr. Larson also manages projects at Ecotope including Pacific Northwest regional efforts to investigate heat pump water heater performance.

## Acknowledgements

Ecotope acknowledges Kumar Banerjee and Tu Bui of Cascade Engineering Inc, in Redmond, WA for the timely and excellent work in conducting the lab testing. We also thank Maho Ito and Charles Yao of Sanden International for support and technical assistance. Jack Callahan and Kacie Bedney of BPA provided guidance and insight in to interpreting the lab data. Additionally, Ecotope thanks Ken Eklund at WSU for being the conceptual and driving force behind the project.

## Abstract

Heat pump water heaters (HPWH) with an outdoor heat exchanger are a promising technology to more efficiently heat water. This project conducted lab tests of a variable-speed, CO<sub>2</sub> refrigerant HPWH with the heat exchanger located in the outdoor unit. The testing plan included observing heat pump efficiency at a range of outdoor ambient temperatures from 17°F to 95°F; conducting the standard 24-hour and 1-hour rating tests; measuring outdoor unit noise levels; and quantifying the number of efficient showers delivered with the outdoor unit operating at 50°F ambient conditions. The tests showed high coefficients of performance and Energy Factors at an outdoor temperature range from 17°F to 95°F. Further, the tests also demonstrated the heat pump maintained output capacity over the temperature range. Overall, the results suggest the HPWH is an extremely efficient heat pump water heater and suitable for all domestic water heating applications in the Pacific Northwest.

## Glossary of Acronyms and Abbreviations

ASHRAE	American Society of Heating, Refrigeration, and Air Conditioning Engineers
BPA	Bonneville Power Administration
Btu	British thermal unit
C	Celsius
CO <sub>2</sub>	carbon dioxide
COP	coefficient of performance
DAQ	data acquisition system
dBA	A-weighted decibel sound level
dBc	C-weighted decibel sound level
DHW	Domestic hot water
DOE	Department of Energy
EF	Energy Factor
EF <sub>NC</sub>	Northern Climate Energy Factor
F	Fahrenheit
ft	feet
GWP	Global Warming Potential
HPWH	Heat Pump Water Heater
kW	kilowatt
kWh	kilowatt hours
NEEA	Northwest Energy Efficiency Alliance
RH	relative humidity
TC	thermocouple
TMY	Typical Meteorological Year
UPC	Uniform Plumbing Code
WSU	Washington State University

## Table of Contents

Glossary of Acronyms and Abbreviations.....	iii
Table of Contents .....	iv
Table of Figures.....	v
Table of Tables .....	v
Executive Summary.....	1
1 Introduction .....	3
2 Methods .....	4
3 Findings: Equipment Characteristics .....	9
3.1 Basic Equipment Characteristics .....	9
3.2 Operating Modes and Sequence of Heating Firing .....	10
4 Findings: Testing Results .....	11
4.1 First Hour Rating and Energy Factor .....	11
4.1.1 1-hour Test.....	11
4.1.2 Energy Factor Tests .....	12
4.1.3 Extended Energy Factor Tests .....	16
4.2 Efficient Showers Test .....	17
4.3 Low Temperature Limit Tests .....	19
4.4 Noise Measurements.....	19
4.5 Compressor Output Capacity and Efficiency.....	19
5 Conclusions .....	23
References .....	24
Appendix A: Testing Matrices .....	25
Appendix B: Measurement Instrumentation List.....	26
Appendix C: Supplemental Graphics.....	27

## Table of Figures

Figure 1. HPWH Outdoor Unit Installed Inside Thermal Chamber.....	5
Figure 2. Hot Water Tank Instrumented and Installed Adjacent to Thermal Chamber .....	5
Figure 3. General Test Setup .....	6
Figure 4. Tank Thermocouple Setup .....	7
Figure 5. Power Measurement Current Transducers .....	7
Figure 6. Power Measurement and Data Acquisition Schematic .....	8
Figure 7. DOE 1-Hour Test.....	12
Figure 8. DOE 24-Hour Simulated Use Test, First Eight Hours .....	13
Figure 9. DOE 24-hour Simulated Use Test. Full 24 hours.....	14
Figure 10. DOE 24-hour, 50°F Ambient Air 50°F Inlet Water. First Eight hours. ....	15
Figure 11. DOE 24-hour, 50°F Ambient Air 50°F Inlet Water. Full 24 hours.....	15
Figure 12. Performance vs. Outside Temperature .....	16
Figure 13. Shower Test Supplemental Draw Profile .....	18
Figure 14. COP Test at 67°F Ambient.....	20
Figure 15. COP Test at 50°F Ambient.....	20
Figure 16. COP at 50°F & 67°F .....	21
Figure 17. Output Capacity at 50°F & 67°F.....	22

## Table of Tables

Table 1. Basic Characteristics for Sanden GAU .....	9
Table 2. Performance Characteristics for Sanden GAU.....	11
Table 3. Efficiency, Output, & Input vs. Outside Temperature .....	16
Table 4. Annual Performance Estimates for 10 Climates.....	17
Table 5. Annual Performance Estimates for Northwest Heating Climate Zones .....	17
Table 6. Sound Level Measurements for Sanden GAU .....	19



## Executive Summary

Under the Advanced Heat Pump Water Heater Research project funded by Bonneville Power Administration (BPA), the Washington State University Energy Program (WSU) contracted with Ecotope, Inc. and Cascade Engineering Services Inc. to conduct a laboratory assessment of the Sanden model # GAU-A45HPA heat pump water heater (HPWH) for northern climate installations. Cascade Engineering evaluated the GAU using a testing plan developed by Ecotope to assess heat pump water heater performance.

The goal of the work: to evaluate the product using an expanded version of the Northern Climate Heat Pump Water Heater Specification (NEEA 2012, *Northern Climate Heat Pump Water Heater Specification* (Specification)). Differing from typical equipment tested under the Specification, which are integrated units, the GAU is a split system, consisting of an outdoor heat exchanger with the tank indoors. The testing plan included observing heat pump efficiency at a range of outdoor ambient temperatures from 17°F to 95°F; conducting the standard 24-hour and 1-hour rating tests; measuring outdoor unit noise levels; and quantifying the number of efficient showers delivered with the outdoor unit operating at 50°F ambient conditions. Overall, the results suggest the GAU is an extremely efficient heat pump water heater and suitable for all domestic water heating applications in the Pacific Northwest. Specific findings include:

- Measured Summary Metrics:
  - Energy Factor (at 67.5°F ambient): 3.35
  - Northern Climate Energy Factor: 3.2
  - First Hour Rating: 97.8 gallons
  - Percent of tank drained before resistance elements engage in 1-hour test: 100+%
    - (note: there are no resistance elements in this tank)
  - Number of consecutive, sixteen-gallon, efficient showers: 7.5
  - Sound level of outside unit: 48 dBA
- The refrigerant used in all of Sanden's HPWH is carbon dioxide (CO<sub>2</sub>). CO<sub>2</sub>, also known as R-744, is widely used in Japan as a response to climate change. The Global Warming Potential (GWP) of CO<sub>2</sub> is 1 as opposed to 2,000 for R-410a and 1320 for R-134a, two typically used refrigerants. R-744 also offers distinct thermodynamic advantages over R-410a and R-134a. R-744 has a broader range of operating temperatures making it well suited for use as the energy exchange medium between cold, outside air temperatures and hot, tank water temperatures. Lab tests showed the equipment had no difficulty heating the tank water to 149°F at an outside temperature of 17°F. Further the manufacturer reports operation to at least -4°F. The operating range makes the equipment well suited for all climates across the Pacific Northwest.
- The inverter-driven, variable speed compressor and fan are efficient and maintain heating output capacity as the ambient temperature decreases. Measured COPs range from 2.1 at 17°F to 5.0 at 95°F. As the outdoor temperature drops, the compressor speeds up. The equipment efficiency decreases but the capacity barely drops. Such characteristics mean the water heater will be able to provide full heating capacity using only the compressor in the winter months.
- The split-system, with the heat exchanger outside, means there are zero parasitic effects on the house heating system. Most heat pump water heaters currently available on the market come as an integrated unit. When the integrated systems are installed inside a house, the HPWH scavenges heat from the house heating system in the wintertime. The split-system has none of these interactive effects.
- Using the measured performance at 17°F, 35°F, 50°F, 67°F, and 95°F, Ecotope estimated annual performance of the water heater in climates across the Pacific Northwest. The estimates are subject to the particular draw pattern used in the test and are influenced by the high set point temperature. For example, the daily draw was 64 gallons in the test. Using a smaller draw of 50 gallons leads to relatively larger standby losses and a lower useful efficiency. Conversely, using a lower set point would increase the heat pump efficiency and decrease standby heat losses. Nevertheless, the calculations provide a

reasonable prediction of performance. The lab testing suggest the following Energy Factors (and, hence annual efficiency) in the Northwest heating climate zones:

- Heating Zone 1: 2.9
  - Heating Zone 2: 2.8
  - Heating Zone 3: 2.6
- There is no resistance element, or any backup heating system with this HPWH. It is designed to always heat with the compressor. This strategy offers significant efficiency advantages because there is no chance for a complicated draw pattern or control strategy to trigger resistance heat as can happen with hybrid HPWHs. At the same time, not having a backup heating method is of potential concern in the event of compressor failure or outdoor temperatures well below 0F, which may prevent the refrigeration cycle from operating.
  - The unit supplied by Sanden is built and marketed in Australia with some market-specific design considerations. The stainless steel tank is relatively large at 85 gallons. The water heater also has a fixed temperature set point of 149°F (65°C). These features resulted in some adaptations being made to the standard testing procedures. Further, it is likely that a tank targeted for the United States market would have a somewhat different configuration and control specifications.
  - The lab testing documents successful performance in the range of climates found in the Pacific Northwest. Based on these findings, a field study of four systems identical to the unit reported in this test will be conducted beginning in fall 2013. Two of the test sites will be located in Heating Climate Zone 1; one in Heating Climate Zone 2; and one in Heating Climate Zone 3.
  - The acoustic tests show decibel levels in a quiet range comparable to the level of sound made by the outdoor unit of a ductless heat pump.



## 1 Introduction

Under the Advanced Heat Pump Water Heater Research project funded by Bonneville Power Administration (BPA), the Washington State University Energy Program (WSU) contracted with Ecotope, Inc. and Cascade Engineering Services Inc. to conduct a laboratory assessment of the Sanden model # GAU-A45HPA heat pump water heater (HPWH) for northern climate installations. Cascade Engineering evaluated the GAU using a testing plan developed by Ecotope to assess heat pump water heater performance. The test plan follows and expands upon that of the Northern Climate Heat Pump Water Heater Specification (NEEA 2012, *Northern Climate Heat Pump Water Heater Specification*). It consists of a series of tests to assess equipment performance under a wide range of operating conditions with a specific focus on low ambient air temperatures.

The tests included measurements of basic characteristics and performance, including first hour rating and Department of Energy (DOE) Energy Factor (EF); determining heat pump efficiency at a range of ambient temperatures from 17°F to 95°F; and conducting a number-of-showers test at 50°F ambient. A table describing all tests performed for this report is included in Appendix A: Testing Matrices.

The water heater tested is currently built and sold in Australia. For the lab evaluation, Sanden supplied the outdoor unit (model # GAU-A45HPA) and water tank (# GAU-315EQTA). The electrical connections accepted the standard power input available in the lab – 240V, 15A, at 60Hz. The water heater is directed specifically at the Australian market which results in different design decisions than those for the United States market. For example, the tank has a copious storage volume, does not have electric resistance elements, and has a fixed temperature set point at 149°F. We evaluated the unit as-is, however, any equipment destined for the United States would likely have a slightly different configuration of tank size, controls, and set point possibilities.

## 2 Methods

Cascade Engineering collaborated with Ecotope and WSU to devise methods and protocols suitable for carrying out the testing plan. Cascade Engineering incorporated the following documents into its procedures:

- The heat pump water heater measurement and verification protocol developed by Ecotope for use in a Bonneville Power Administration project (Ecotope 2010).
- Northern Climate Specification for Heat Pump Water Heaters (Northwest Energy Efficiency Alliance 2012)
- Department of Energy (DOE) testing standards (DOE 1998) from Appendix E to Subpart B of 10 CFR 430
- American Society of Heating, Refrigeration, and Air Conditioning Engineers (ASHRAE) Standard 118.2-2006 (ASHRAE Std. 118.2)

The general approach and methodological overview for this test are provided here. All figures and schematics in this section are courtesy of Cascade Engineering.

In alignment with the type of test conducted, Cascade Engineering carried out the testing at three different locations within its facility:

- Inside an ESPEC Model # EWSX499-30CA walk-in thermal chamber;
- In a large lab space not thermally controlled, but kept at room-temperature conditions; and
- In a room with low ambient noise.

The GAU water heater, with an outdoor heat exchanger presents a unique challenge to the current heat pump water heater testing specifications. The specifications developed by DOE and ASHRAE assume the air-to-refrigerant heat exchanger is inside the conditioned space (standard ambient test conditions of 67.5°F). The GAU heat exchanger is installed outside the house. Therefore, the most important temperatures to control for the test are the ambient temperatures. Accordingly, the test plan places the outdoor unit inside the thermal chamber where it is subject to a range of temperatures. The hot water tank itself is placed next to the chamber in the large lab space. That lab space is kept thermally controlled only by a typical space heating thermostat. The temperature typically varied from 60°F to 70°F. This small change in temperature will lead to a slight change in the overall heat loss of the tank but the impacts on the overall system efficiency measurements are minimal.

Because the DOE and Draw Profile type tests require tight controls on the ambient air conditions, Cascade Engineering conducted all those tests with the outdoor unit in the thermal chamber. The chamber is capable of regulating both temperature and humidity over wide ranges. The chamber independently monitors and records temperature and humidity conditions at one-minute intervals. Figure 1 shows the HPWH installed inside the thermal chamber. The test plan did not require tightly-controlled conditions to conduct any one-time measurements of system component power levels, so those tests were conducted in the large lab space at the conditions encountered at the time. Figure 2 shows the hot water tank adjacent to the thermal testing chamber. Lastly, Cascade Engineering moved the HPWH to a room with ambient noise levels below 35dBA to measure the noise emanating from the operating equipment.

**Figure 1. HPWH Outdoor Unit Installed Inside Thermal Chamber**



**Figure 2. Hot Water Tank Instrumented and Installed Adjacent to Thermal Chamber**

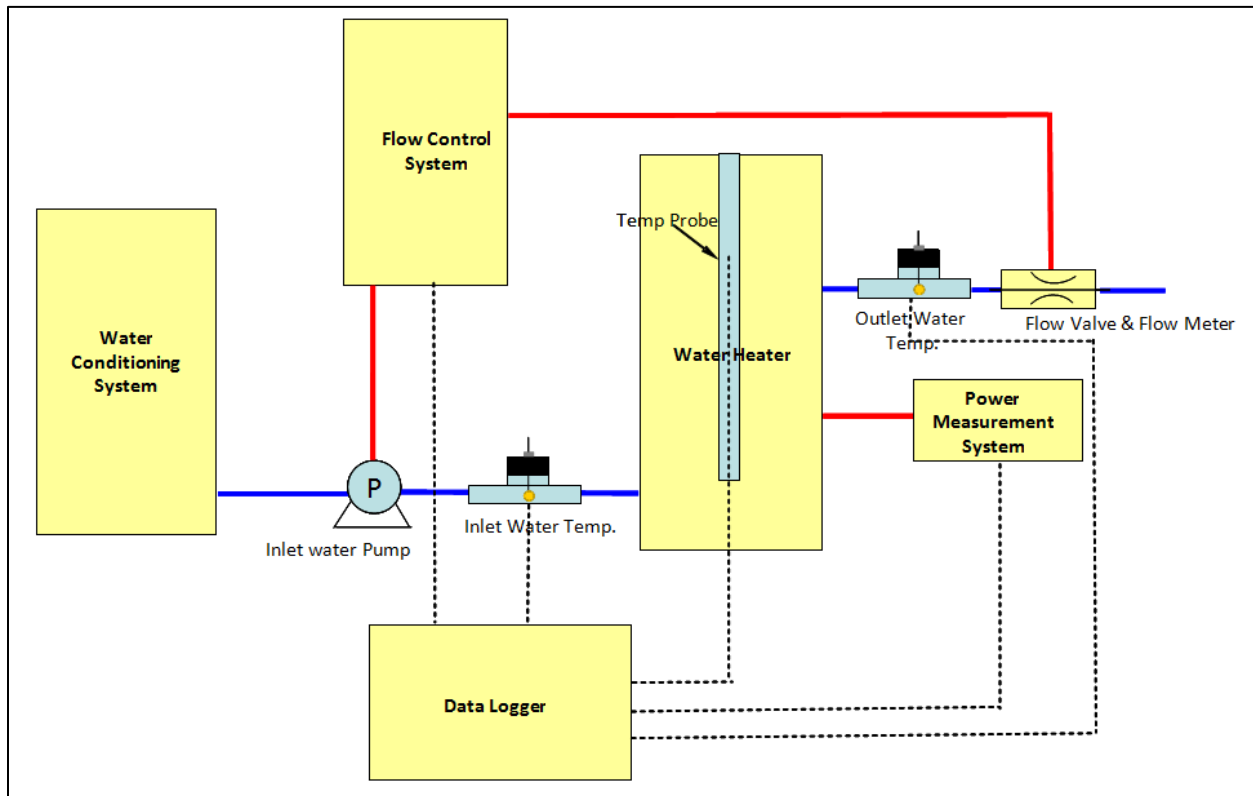

Figure 3 shows a schematic of the general test setup. Cascade Engineering installed an instrumentation package to measure the required points specified by the DOE test standard, as well as additional points to gain further insight into HPWH operation.

The series of six thermocouples positioned at equal water volume segments measuring tank water temperature warrants special mention. Most electric water heaters have an anode rod port at the top of the tank which offers convenient access for inserting a straight thermocouple tube near the central axis. Because the GAU tank is all stainless steel and there are no resistance heating elements, there is no need for an anode rod. Without the convenient anode port, Cascade Engineering used another measurement method suggested by Sanden’s engineers to use the pressure relief valve port on the side of the tank. Figure 4 illustrates the unique “fishing rod” approach. The thermocouples hang freely in the tank so, to keep them positioned, the lab attached weights to the bottom of the thermocouple wire.

Cascade Engineering measured inlet and outlet water temperatures with thermocouples immersed in the supply and outlet lines. Three thermocouples mounted to the surface of the evaporator coil at the refrigerant inlet, outlet, and midpoint monitored the coil temperature to indicate the potential for frosting conditions. Power for the equipment was monitored for the entire unit including the compressor, fan, and pump all at once (Figure 5 and Figure 6). Cascade Engineering made a series of one-time power measurements for other loads, including the control board and the fan. Appendix B: Measurement Instrumentation List, provides a complete list of sensors, including others in addition to those mentioned here, plus their rated accuracies.

**Figure 3. General Test Setup**



**Figure 4. Tank Thermocouple Setup**

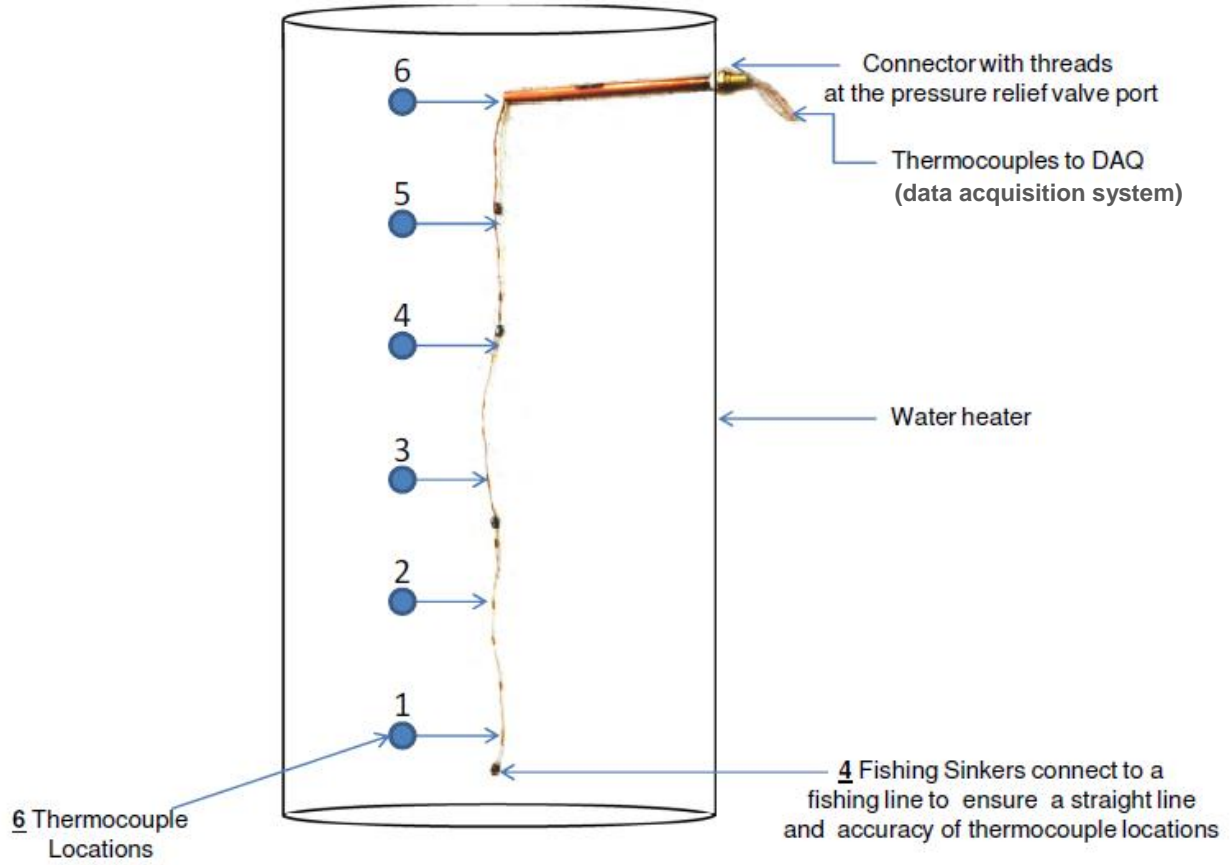

**Figure 5. Power Measurement Current Transducers**

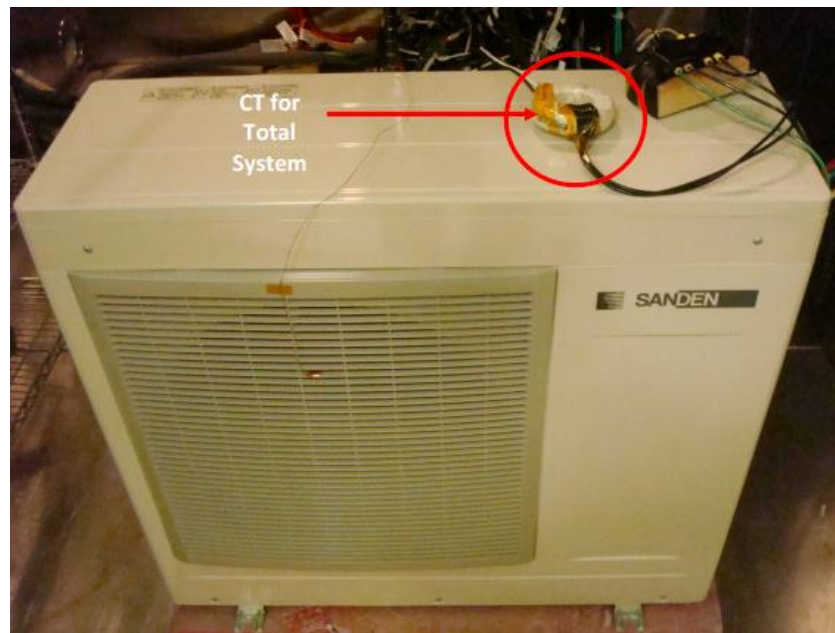

**Figure 6. Power Measurement and Data Acquisition Schematic**

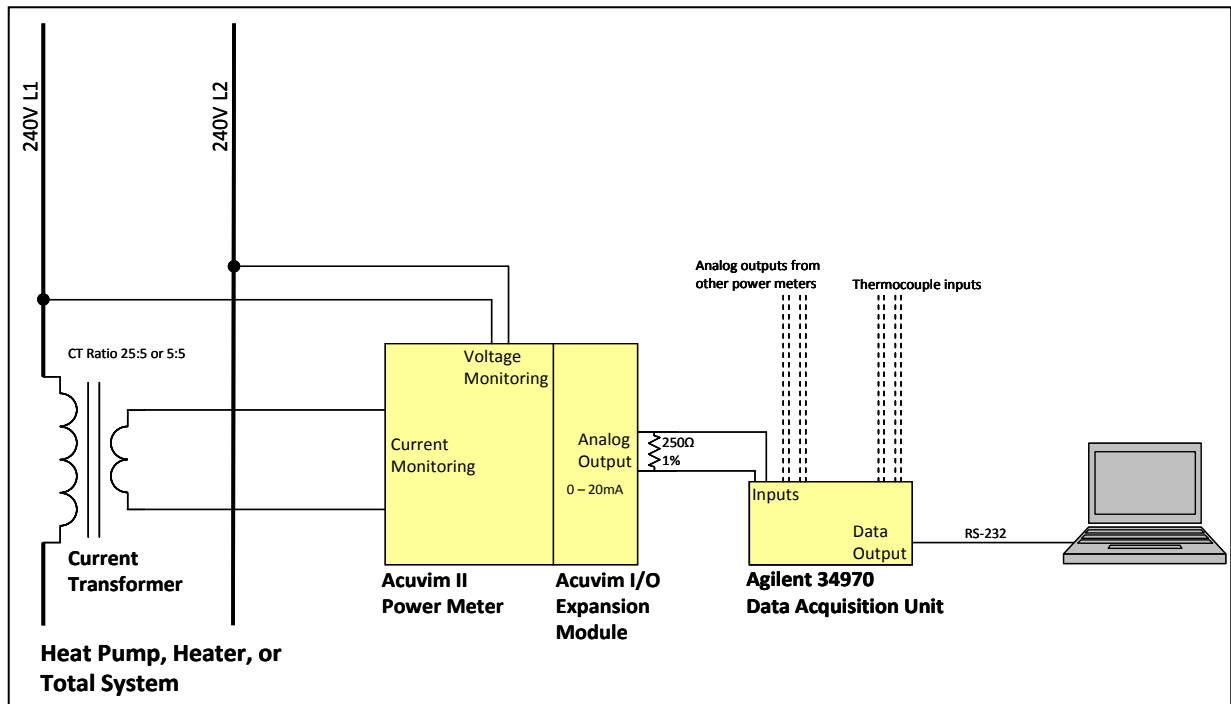

Cascade Engineering conditioned and stored tempered water in a large tank to be supplied to the water heater at the desired inlet temperature. A pump and a series of flow control valves in the inlet and outlet water piping control the water flow rate. A flow meter measures and reports the actual water flow.

A data acquisition (DAQ) system collects all the measurements at five-second intervals and logs them to a file. In a post processing step, Ecotope merged the temperature log of the thermal chamber with the DAQ log file to create a complete dataset for analysis.

Whenever possible, Cascade Engineering conducted all tests to align with the DOE and ASHRAE specifications. As noted previously, the nature of the equipment tested required the testing plan to deviate from standard methods to account for testing a unit with an outdoor heat exchange and indoor tank. The exceptions are described as follows:

- The outdoor unit was placed in a climate controlled thermal chamber.
- The indoor tank was placed in a room with ambient temperatures allowed to typically float between 60°F and 70°F.
- The plumbing between the indoor tank and outdoor unit was insulated with 1" thick pipe insulation per installation manual recommendations.
- The pump for conditioned water maintained the supply pressure near 20psi rather than the 40+psi of the spec.
- Water inlet and outlet supply piping consisted of the cross-linked polyethylene (PEX) variety rather than copper.
- The lab took inlet and outlet water temperature measurements two feet from the tank.

In all, Ecotope expects the deviations from the standard protocol to produce minimal differences in testing outcomes.

### 3 Findings: Equipment Characteristics

#### 3.1 Basic Equipment Characteristics

The GAU HPWH is an all-electric water heater consisting of a heat pump integrated with a hot water storage tank. The equipment has a single method of heating water: using a heat pump to extract energy from the outside air and transfer it to the water.

All of the equipment’s active components including compressor, condenser, evaporator, fan, and water pump are located in a single, outdoor unit. The outdoor unit is shaped like a typical space conditioning mini-split heat pump but instead of having refrigerant piping running to the house, it has water piping. A pump circulates water, not refrigerant between the outdoor unit and indoor tank. All of the heat exchange is done in the outdoor unit. In this sense, the heat pump is not strictly a “split-system.”

A variable speed fan draws air across the evaporator coils absorbing heat from the ambient environment. The CO<sub>2</sub>-based refrigerant cycle transfers the heat to the condenser side of the unit which is in thermal contact with the water. The water pump pulls cold water out of the bottom of the indoor tank, across the condenser, and re-injects hot water into the top of the tank. The equipment heats the water from cold to hot in a single pass.

The lab conducted a series of measurements comprising a basic descriptive characterization of the system’s performance. These are shown in Table 1 and are discussed in the rest of this section.

Unlike traditional electric tank water heaters, the GAU contains no electric resistance heating elements. The water heater heats solely with a variable speed, inverter-driven compressor. Measurements show the outdoor unit, including compressor, fan, and water pump, draws 0.9kW to 2.4kW depending on both tank water and ambient air conditions. The compressor increases speed, and therefore power draw, as the ambient temperature decreases in order to maintain heating output capacity. At 95°F, the outdoor unit draws 0.9kW for most of the heating cycle. As the overall water temperature in the tank increases, the power draw increases as well to 1.05kW. At 17°F, the unit draws 1.9kW for most of the cycle ending with 2.4kW.

Two other components of the equipment also consume power: the outdoor unit fan and the water circulation pump. Both components run concurrently with the compressor and their power draw is included in all the measurements. Like the compressor, the fan is also variable speed. The lab made several one-time measurements of the fan power although never while one of the tests was running. The fan draws 9W-77W depending on speed. The lower powers and air flows occur at the higher air temperatures. The pump power draw was not measured independently. Last, measurements of standby power show the unit uses <1W when idle.

The GAU-315EQTA tank has a nominal 315 liter (83.2 gallon) capacity. Measurements showed the unit in the lab held 84.6 gallons. Per discussions with the manufacturer, it is possible to connect different tank storage volumes to the same outdoor unit.

The GAU uses R-744 refrigerant, otherwise known as CO<sub>2</sub>. R-744 offers some distinct advantages over two typically used HPWH refrigerants: R-410a and R-134a. R-744 has an broader range of operating temperatures making it well suited for use as the energy exchange medium between cold outside air temperatures and hot tank water temperatures. Lab tests showed the equipment had no difficulty heating the tank water to 149°F at an outside temperature of 17°F. That corresponds to a 132F temperature lift. R-744 also has a Global Warming Potential (GWP) of 1, as opposed to 2,000 for R-410a and 1,320 for R-134a.

**Table 1. Basic Characteristics for Sanden GAU**

Component	Measurement / Description
Resistance Elements	None
Outdoor Unit <sup>†</sup> (W)	900-2,400
Standby (W)	< 1
Tank Volume (Gallons)	84.6
Refrigerant	R-744 (CO <sub>2</sub> )

Notes: <sup>†</sup>Range depends on water and ambient temperature.

### **3.2 *Operating Modes and Sequence of Heating Firing***

The HPWH has an integrated circuit control board, located in the outdoor unit, which may be programmed in a number of ways to control when the heat pump turns on and off. Sanden has developed a basic control strategy as well as several variations related to off-peak electricity usage. The basic control strategy was used for all the testing in this report and is described here.

The current version of the tank controls has a fixed temperature set point of 149°F (65°C). The set point is not user adjustable. For control points, there is a single thermistor monitoring the tank temperature located approximately 1/3 of the water volume from the top of the tank. When that thermistor senses a water temperature below 113°F (45°), the tank turns on the compressor to begin heating. When the tank reaches its set point, the heat pump cycles off.

Control logic that is internal to the equipment determines the compressor and fan speed settings. As the outdoor temperature decreases, the compressor increases its power draw. Lab testing showed the equipment attempts to maintain 4kW of heating output regardless of outdoor temperature.



## 4 Findings: Testing Results

### 4.1 First Hour Rating and Energy Factor

The DOE has established two tests to rank the comparative performance of HPWHs. The first (1-hour) test produces a first hour rating that determines how much useable hot water the heater makes in one hour. The second, a 24-hour simulated use test, produces an energy factor (EF) that identifies how much input energy is needed to generate the 64.3 gallons of hot water used in the simulated 24-hour period. For tank-type water heaters, the first hour rating depends largely on tank volume and heating output capacity, while the EF depends on the heating system efficiency and the heat loss rate of the tank.

Given that the testing conditions set the ambient air at 67.5°F and assume the water heater is in conditioned space, applying the same test to an unit located outdoors, which is subject to a different temperature regime, does not tell the complete story of the GAU performance. Still, for comparison purposes to other HPWHs, we conducted the 1-hour and 24-hour tests at standard conditions. The normative performance characteristics of the equipment are shown in Table 2 and are discussed in the rest of this section. Although the lab carried out the tests to align with the DOE specifications, the outputs here should be considered advisory only – any certified ratings will be those reported by the manufacturer.

The lab conducted the tests with the GAU in its default mode as described in section 3.2. The results are shown in Table 2. A key item to note for these tests is that the tank set point was fixed at 149°F instead of the normative 135°F value. Ecotope expects testing at a lower set point would lead to improved performance. In addition to performing the tests at the standard rating conditions, Cascade Engineering conducted several other similar tests. The second EF-type test used the same methods and draw patterns but different environmental conditions of 50°F ambient air / 50°F inlet water, the conditions used to determine the Northern Climate Energy Factor. Further, the lab conducted more EF-type tests at 17°F, 35°F, and 95°F which are discussed in subsequent sections.

**Table 2. Performance Characteristics for Sanden GAU**

<b>Metric</b>	<b>Measured Value</b>
First Hour Rating (gal)	97.8
Energy Factor (std. conditions)	3.35
Energy Factor @ 50°F Ambient	3.11
Northern Climate Energy Factor	3.2
Tank Heat Loss Rate (Btu/hr°F)	4.0

#### 4.1.1 1-hour Test

The data from the 1-hour test are plotted in Figure 7. The test begins with a 3gpm draw. Approximately 20 minutes into the first draw, the heat pump activates (green line showing 1kW). As the draw continues past twenty-five minutes, the water temperature at the outlet has fallen more than 25°F so the first draw is terminated. The heat pump continues to heat the tank until minute 60. At that time, per the DOE test method, this triggers the final draw which terminates when the outlet temperature again drops below 124°F.

The Northern Climate Specification uses the 1-hour test data to determine how many gallons of hot water are withdrawn in the first draw before the resistance element turns on – a critical indicator of overall operational efficiency for hybrid heat pump water heaters. For this tank, with no resistance elements, we see it can provide 84 gallons of hot water in the first draw all of which is heated with the heat pump.

Figure 7. DOE 1-Hour Test

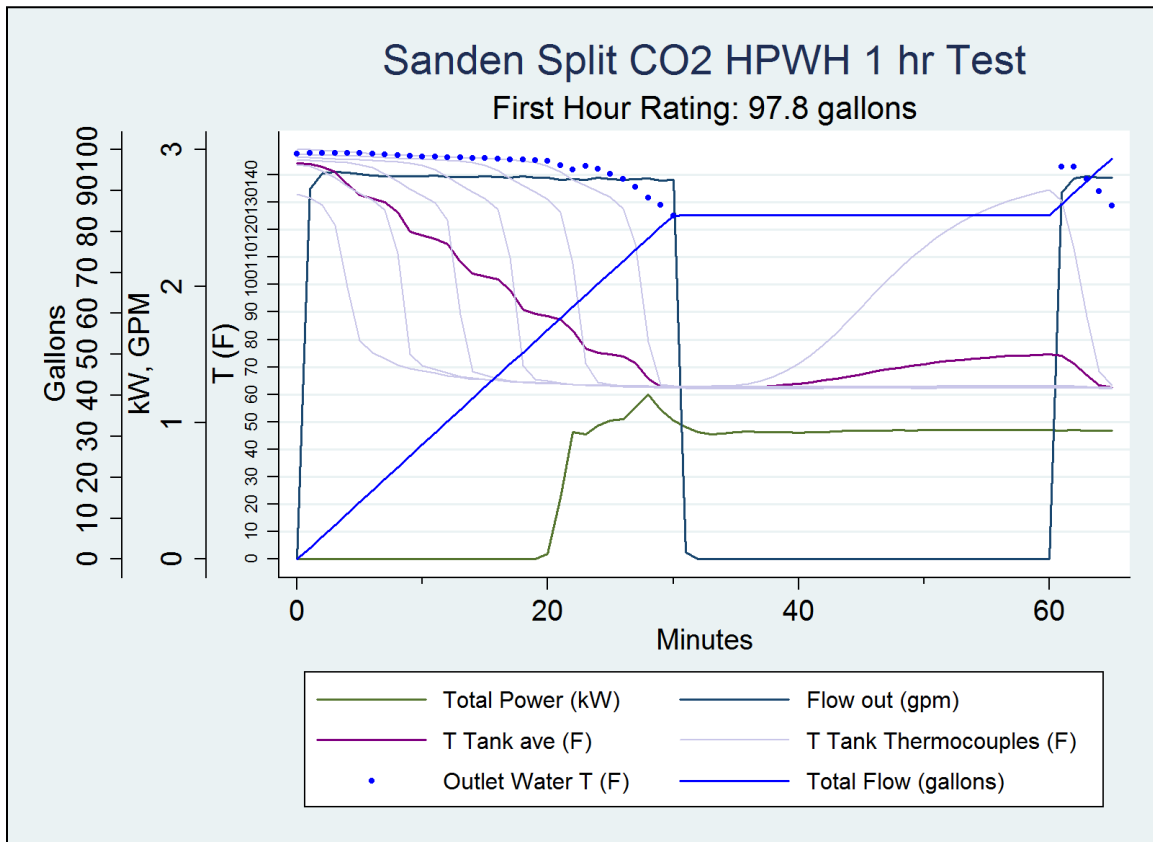

Notes: The bright blue line shows the cumulative water drawn during the test. The green line plots the total equipment power consumption. The thick purple line displays the average tank temperature, while the thin lavender lines show the temperatures reported from the six thermocouples placed at different heights (corresponding to equal volume segments) within the tank (in effect a temperature profile of the tank at any point in the test). Lastly, the blue dots plot the outlet water temperature.

### 4.1.2 Energy Factor Tests

The 24-hour simulated use test consists of six 10.7-gallon draws equally spaced over six hours, followed by eighteen hours of standby. The standard test conditions are 67.5°F, 50% relative humidity (RH) ambient air, 135°F tank set point (this tank used 149°F) and 58°F incoming water temperature. The lab also performed the 24-hour simulated use test at colder ambient conditions of 50°F ambient air and 50°F inlet water. As part of the Northern Climate Heat Pump Water Heater Specification, the test results demonstrate the variation in performance with varied ambient conditions.

The EFs for the 67°F and 50°F tests are displayed in Table 2. They are calculated with the DOE method but with different ambient conditions where relevant for the 50°F ambient test. The Northern Climate Heat Pump Water Heater Specification provides a calculation method for determining the Northern Climate Energy Factor (EF<sub>NC</sub>); it is a weighted combination of the EF at 67°F and 50°F using a temperature bin profile. The procedure also uses the lowest ambient temperature at which the compressor no longer operates. For the temperature bins below that cutoff, the procedure assumes performance equal to that of resistance heating. The higher the compressor cutoff temperature, the lower the overall EF<sub>NC</sub> will be (for details, see the Northern Climate Heat Pump Water Heater Specification). In the calculations, Ecotope used the -4°F temperature bin cutoff as determined through discussions with the manufacturer.

Figure 8 shows the first eight hours of the test so the draw events and recovery can be examined in more detail. Figure 8 also plots the instantaneous coefficient of performance (COP), a measure of the amount of heat added

to the hot water in a given time interval divided by the energy used to create or deliver that heat in that interval (in this case five minutes). The COP for electric resistance heat is generally assumed to be 1.0; in contrast, the COP for heat pumps can vary greatly depending largely on the ambient air conditions (heat source) and the tank temperature (heat sink). The apparent oscillation of the COP in Figure 8 from hour 4 to hour 6.5 is an artifact of the measurement system. There are six, discrete temperature sensors inside the tank at increasing heights. The tank is so well stratified that the temperature sensors don't register a change in the 1/6 of the water volume segment they are assigned until just before the hot water reaches their height. This results in an uneven, but predictably periodic, apparent change in output energy. The actual COP for the time period is the midpoint of those oscillations – nearly 4.5. At hour 6.5, the tank is almost completely hot and the water circulating passed the heat exchanger is warming up. This increases the heat sink temperature and therefore lowers the COP to near 1 at the end of the heating cycle. This behavior is seen in every tank recovery cycle.

Figure 8. DOE 24-Hour Simulated Use Test, First Eight Hours

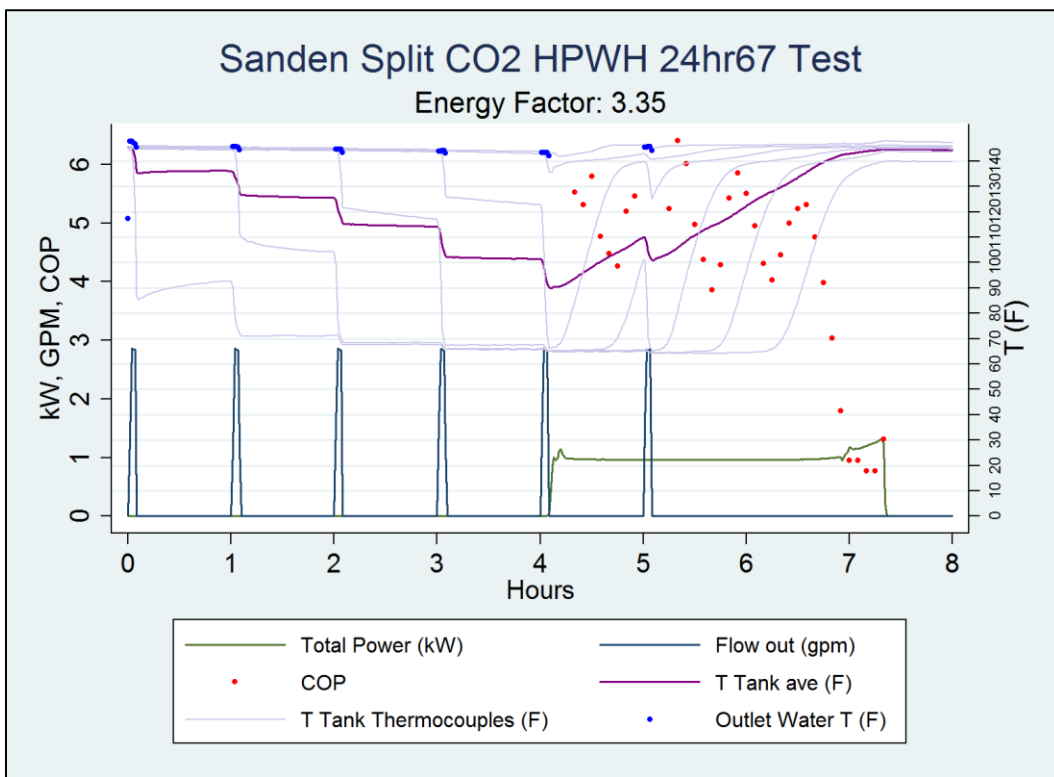

Figure 9 shows the full 24 hours, which also illustrates the tank heat loss rate. The test starts with the tank at 145°F. After the recovery cycle at eight hours, the tank is also at 145°F. Sixteen hours later, the average tank temperature has dropped to 135°F. The graph shows a very short heat pump cycle at 10.5 hours which amounts to a small standby recovery to the tank.

**Figure 9. DOE 24-hour Simulated Use Test. Full 24 hours.**

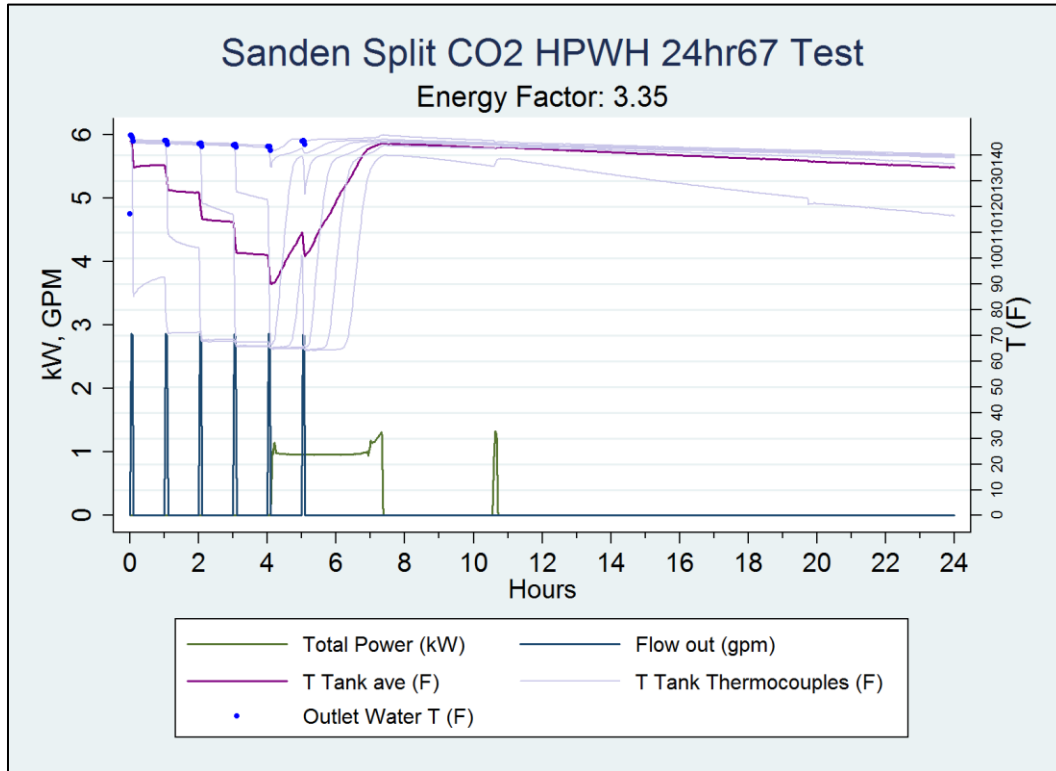

Figure 10 and Figure 11 plot the heat pump behavior for the 50°F ambient air and 50°F inlet water 24-hour testing conditions. The graphs look nearly identical to the ones at 67°F ambient air. At 50°F ambient air, the unit runs at nearly the same input power but with a slightly lowered COP. The compressor must run an extra 30 minutes to heat the lower inlet temperature water and to compensate for a slightly reduced output capacity.

Figure 10. DOE 24-hour, 50°F Ambient Air 50°F Inlet Water. First Eight hours.

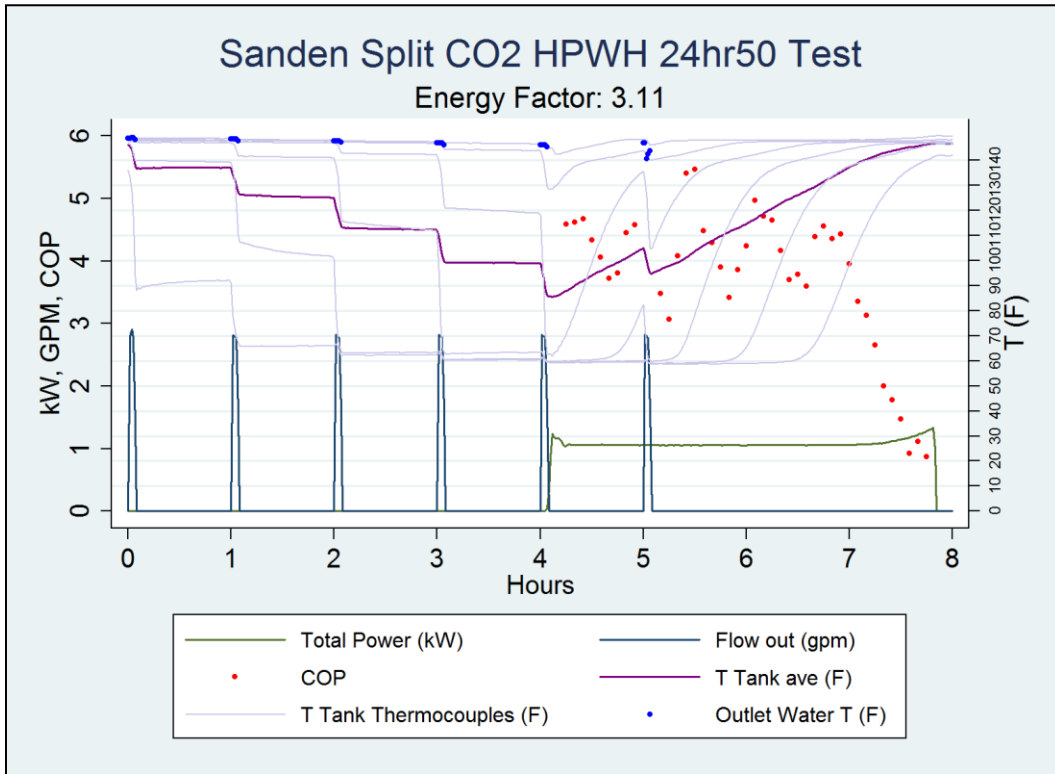
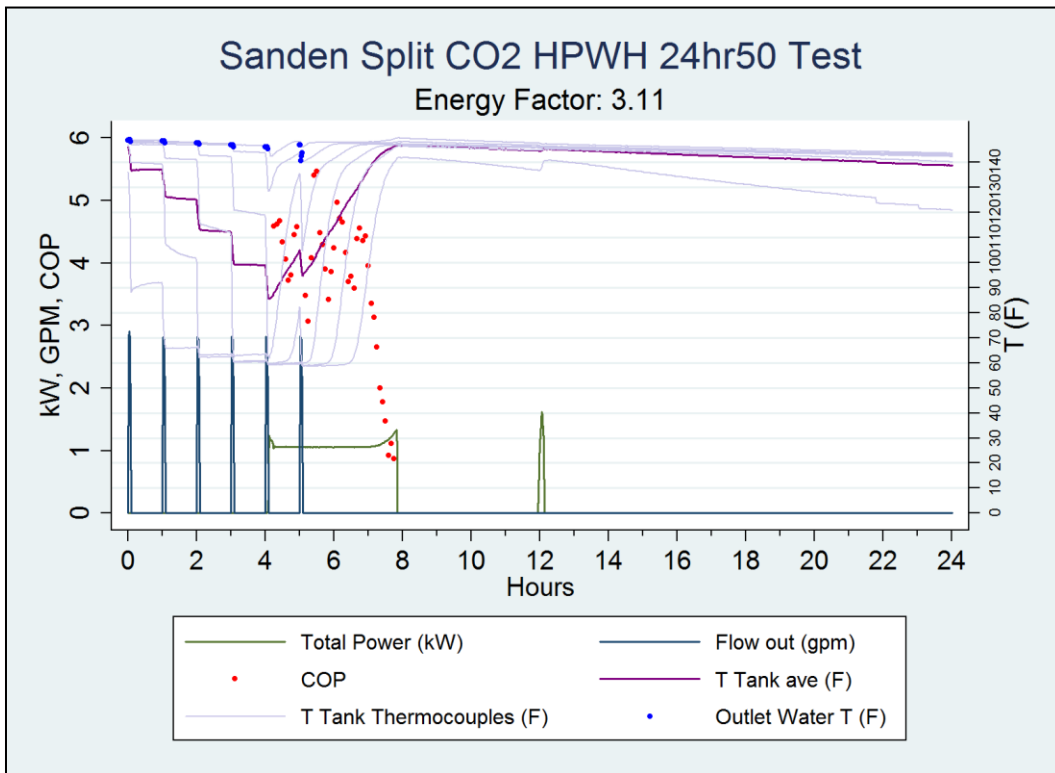

Figure 11. DOE 24-hour, 50°F Ambient Air 50°F Inlet Water. Full 24 hours.



### 4.1.3 Extended Energy Factor Tests

The testing plan called for exploring a full range of outdoor conditions from 17°F to 95°F. By measuring the performance over a wider temperature range, it is possible to produce an estimate of annual system operating efficiency. We opted to use the DOE 24-hr test draw pattern for all the tests to stay consistent and comparable with the standard conditions. In addition to varying the air temperature, the two exceptions made were to use an inlet water temperature of 50°F and tank set point at 149°F.

Table 3 summarizes the results of the tests. The table shows the Energy Factor calculated at the tested conditions, the average COP of the equipment over the entire active heating period, the average output capacity over that period, and the average input power. The tests show how the equipment controls manage the variable speed compressor to maintain output capacity even as the temperature drops. As the outside temperature decreases from 67°F to 17°F, the compressor input power doubles to keep the output capacity at 4kW. The table also shows that while the equipment could ramp up input power at 67°F to increase the heating output it does not do so in favor of more efficient operation. Additionally, Table 3 shows remarkable operational COPs for any heat pump. This high performance is due in part to a large output heat exchange surface area but also lower power components such as the compressor and fan.

See Appendix C: Supplemental Graphics for the graphs for the 17°F, 35°F, and 95°F.

**Table 3. Efficiency, Output, & Input vs. Outside Temperature**

Outside Air Temperature (F)	Energy Factor (EF)	COP	Output Capacity (kW)	Input Power (kW)
17	1.74	2.1	4.0	1.9
35	2.21	2.75	3.6	1.3
50	3.11	3.7	4.0	1.1
67	3.35	4.2	4.1	0.97
95	4.3	5.0	4.6	0.93

By measuring the equipment efficiency over a range of outdoor temperatures it is possible to create a function characterizing its performance. Figure 12 shows the EF values plotted against temperature. The performance appears surprisingly linear. The equation displayed on the graph shows the functional fit.

**Figure 12. Performance vs. Outside Temperature**

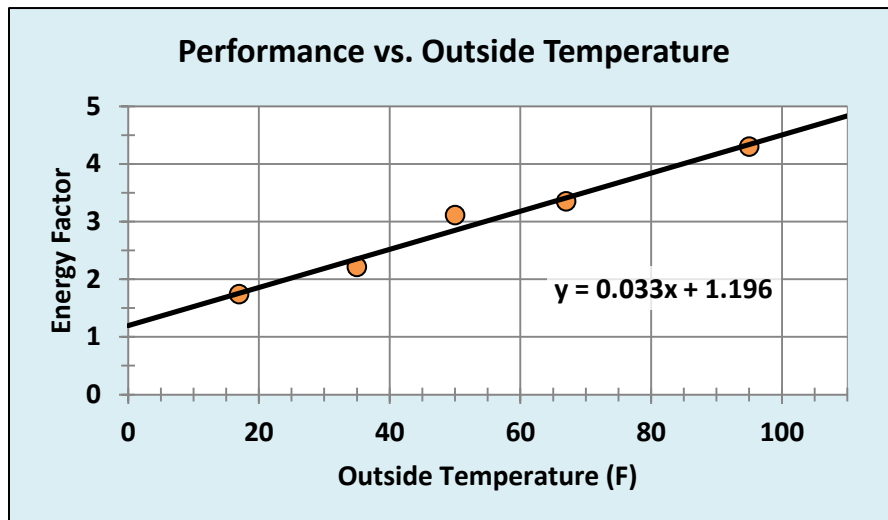

Once the performance curve is known, we can estimate annual water heating performance by applying it to different climate temperature profiles. The calculation is a standard temperature-bin weighted calculation using TMY3 data to provide the number of hours for each temperature bin. Table 4 shows the results for five cities in the Pacific Northwest and five additional cities across the country. Table 5 shows the estimates for the three Pacific Northwest heating zones.

**Table 4. Annual Performance Estimates for 10 Climates**

Climate	Annual EF	Climate	Annual EF
Boise	2.9	Minneapolis	2.7
Kalispell	2.6	Raleigh	3.2
Portland	3.0	Boston	2.9
Seattle	2.9	Chicago	2.9
Spokane	2.8	Houston	3.5

**Table 5. Annual Performance Estimates for Northwest Heating Climate Zones**

Heating Zone	Annual EF
1	2.9
2	2.8
3	2.6

## 4.2 Efficient Showers Test

In addition to the standard and modified DOE tests, the Northern Climate Specification calls for a delivery rating test to better understand performance. This simulated-use, “Shower Test” (DP-SHW) describes the number of efficient hot showers the HPWH is capable of providing. The test specification is for 50°F ambient air, 50°F inlet water, and set point of 120°F. The Sanden GAU test set point is 149°F. To mimic a series of morning showers, the lab conducted repeated eight-minute draws at two gallons per minute. The draws were separated by a five-minute lag time and continued until either the resistance element activated or the outlet temperature fell below 105°F. When one of these events occurred, the current draw was allowed to finish, the tank to recover, and the test concluded. Based upon the findings of this test, the GAU water heater provides 7.5 consecutive efficient showers. The results of the test are displayed in Figure 13.

If the tank temperature were set at 120°F per the usual test specifications, the temperature drop below 105°F would happen sooner resulting in a lower shower delivery rating. The point where the outlet drops 15°F on the graph occurs during the seventh shower. Consequently, we expect the shower delivery rating to be approximately 6.5 under standard test conditions.

If, however, the tank was kept at the higher temperature and mixed with cold water down to 120°F, it would produce more showers. This is the design of other Sanden HPWH, and is how the GAU will be installed in the field tests that are part of the Advanced Heat Pump Water Heater Research Project. To emulate the effect of a tempering valve the water flow during the test draws was reduced to compensate for the higher stored temperature. Because of this test modification, the 7.5 showers measured are the number which can be expected in the field installation.

Figure 13. Shower Test Supplemental Draw Profile

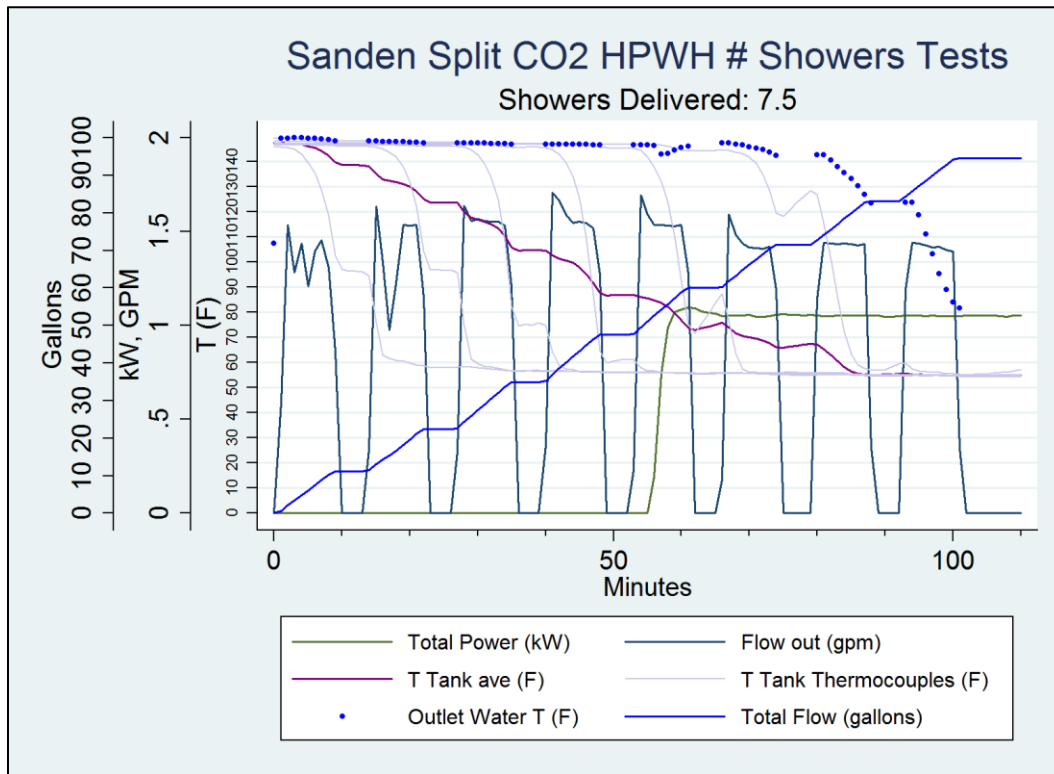

Both the DOE 1-hour and number of showers tests amount to delivery ratings. The Uniform Plumbing Code (UPC) 2009 uses the 1-hour test output (the first hour rating) for tank sizing requirements. Crucially, neither the UPC nor the DOE 1-hour test is concerned with the efficiency with which that first hour rating is obtained. Indeed, the delivery rating efficiency of older water heating technologies, including electric resistance and gas-fired tanks, turned out to be largely irrelevant. Those tanks, with only one means with which to heat water, could use two outputs from the DOE 24-hour test – the recovery efficiency and energy factor – to reliably describe the operational efficiency during the 1-hour tests. In contrast, typical hybrid HPWHs have two distinct heating efficiencies depending on which of the two heating methods the control strategies use. Consequently, the showers test provides additional insight into how much hot water the tank can *efficiently* deliver. The Sanden GAU is different in that it only has a single heating method. With only one heating option, it always delivers water in the most efficient way.

The UPC requires a minimum capacity (first hour rating) for a water heater based on number of bathrooms and bedrooms. Both are proxies, respectively, for water demand and number of people in a house.<sup>1</sup> Referencing the UPC minimum sizing table shows that the GAU's first hour rating of 98 gallons handily meets the sizing requirements for any residential installation. Further, the showers test demonstrates that the water heater will always meet that load with the efficiency of its heat pump system. The large storage volume is the main factor in meeting the requirements but the fact that the heater is designed to achieve high output levels from the compressor alone is also important to satisfying water demand.

<sup>1</sup> The number of people in a house is often taken to be number of bedrooms plus one. For an example, see ASHRAE Std. 62.2.



### 4.3 Low Temperature Limit Tests

The GAU has no resistance element backup so a critical question to know before deploying these in the field is outside temperature lower operating limit. The lab testing observed compressor operation at 17°F but did not simulate any colder temperatures. The 17°F low temperature test is approaching the operational limits of the particular testing chamber used. The manufacturer, however, reports that they have observed heat pump operation at -4°F. Our lab tests support that statement in that we observed no difficulty in compressor operation at 17°F. In fact, the heat pump maintained an output of nearly 4kW with a COP of 2 even at these cold conditions.

### 4.4 Noise Measurements

The lab also measured the sound level of the equipment. In this case, the measurements are made for the outdoor unit since there are no moving parts at the tank. The lab placed the unit in a room near a wall and then measured the sound level at five different points on a circumference 3ft distant and 2ft high. They repeated the measurement at a 5ft high as well. The ambient temperature for the test was ~65°F. Table 6 shows the background levels and the averages of the five measurements. These levels show quiet operation within the range of the outdoor units for ductless heat pumps.

**Table 6. Sound Level Measurements for Sanden GAU**

Decibel Weighting	Background	HPWH On 2 ft height	HPWH On 5ft height
dBA	37.7	46.4	44.8
dBC	62.4	63.7	62.3

### 4.5 Compressor Output Capacity and Efficiency

To better understand the HPWH performance, the testing plan called for mapping the compressor heat pump COP at varied tank temperatures and ambient air conditions. These COP measurements reflect how efficiently the heat pump components of the HPWH are operating under any given set of conditions. The COP test begins with the tank full of 55-65°F water. The heat pump is then turned on and the tank heats up to near set point (149°F). During the test, data loggers record the change in tank temperature (equivalent to output energy) and the equipment input energy. The quotient of the two is the COP.

Figure 14 plots the COP test at 67°F ambient temperature. As described earlier in the report, the actual COP points plotted are sometimes deceiving owing to the nature of the measurement system. The tank is highly stratified in temperature – so much so that one can think of a sharp line demarcating the boundary between cold and hot water (the thermocline). The output capacity is calculated via the change of tank temperature as measured by six evenly spaced thermocouples. As the thermocline moves through the tank, those thermocouples experience alternately rapid and slow changes in temperature. This uneven pace produces the apparent oscillation in the COP plots until the very bottom thermal couple is heated up and the tank is at a near uniform temperature.

Figure 14 shows an almost complete tank drain-out between minutes zero and eight. We then see the heat pump turn on and heat up the tank. The thermocline of hot water moves down the tank starting with thermocouple six (TC6), then to thermocouple five (TC5), and so on.

Figure 15 displays the COP test at 50°F ambient.

Figure 14. COP Test at 67°F Ambient

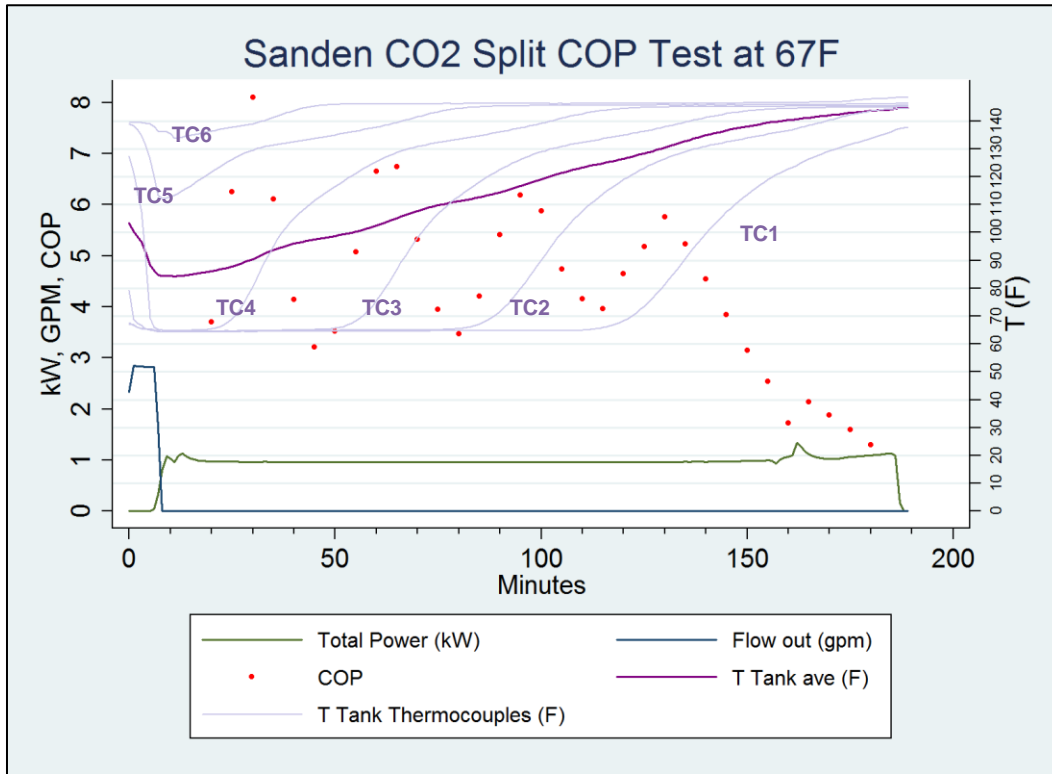
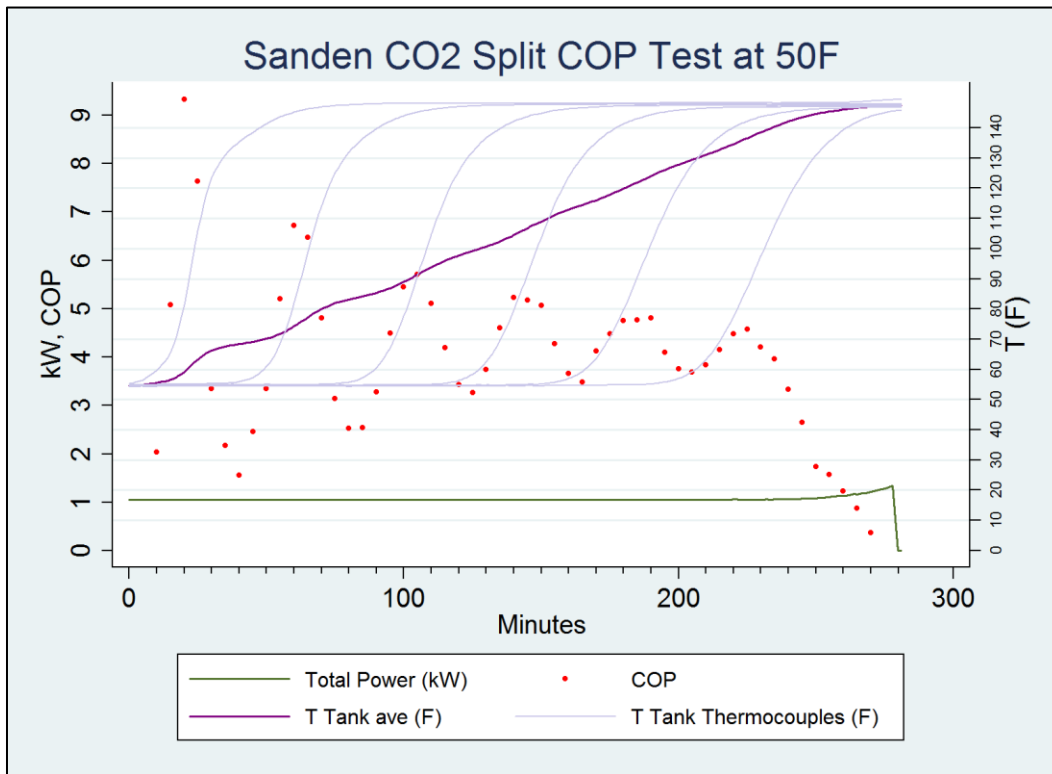

Figure 15. COP Test at 50°F Ambient



We produce a curve that describes the relationship between water temperature and COP over a heating cycle. The relevant water temperature for this heat pump is that at the bottom of the tank which is piped to the condenser. Figure 16 shows the COP for the tests at 50°F and 67°F drawn as curves. There appears to be a range of COPs but that is misleading – at 67°F air temperature and 65°F water temperature, the COP is 5 (not 3 to 8.5).

In both Figure 16 and Figure 17 the curves cross at the warmer water temperatures near 110°F. The cross-over is unexpected and likely not a robust result. The COP and capacity at 50°F are lower than at 67°F. These two COP tests reflect these facts until the warmest tank temperatures are reached. At that point, we think the COP behavior changes because the initial tank conditions differed. The 50°F test started with ten degree colder water in the tank which would have the effect of preserving a high COP longer in the test. Essentially, the different initial testing conditions likely had an impact on the output capacity at this later stage. Overall, one shouldn't draw comparisons between the two temperature tests. Table 3 is most representative of the performance differences across temperatures.

Figure 16. COP at 50°F & 67°F

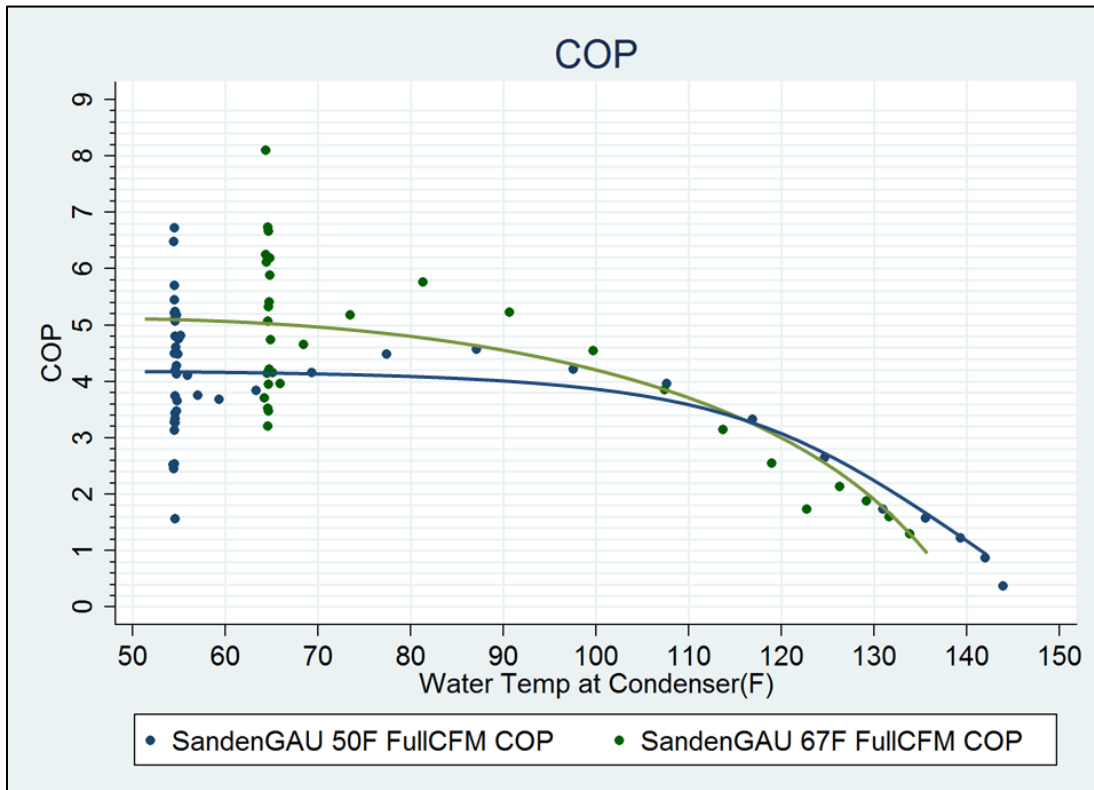
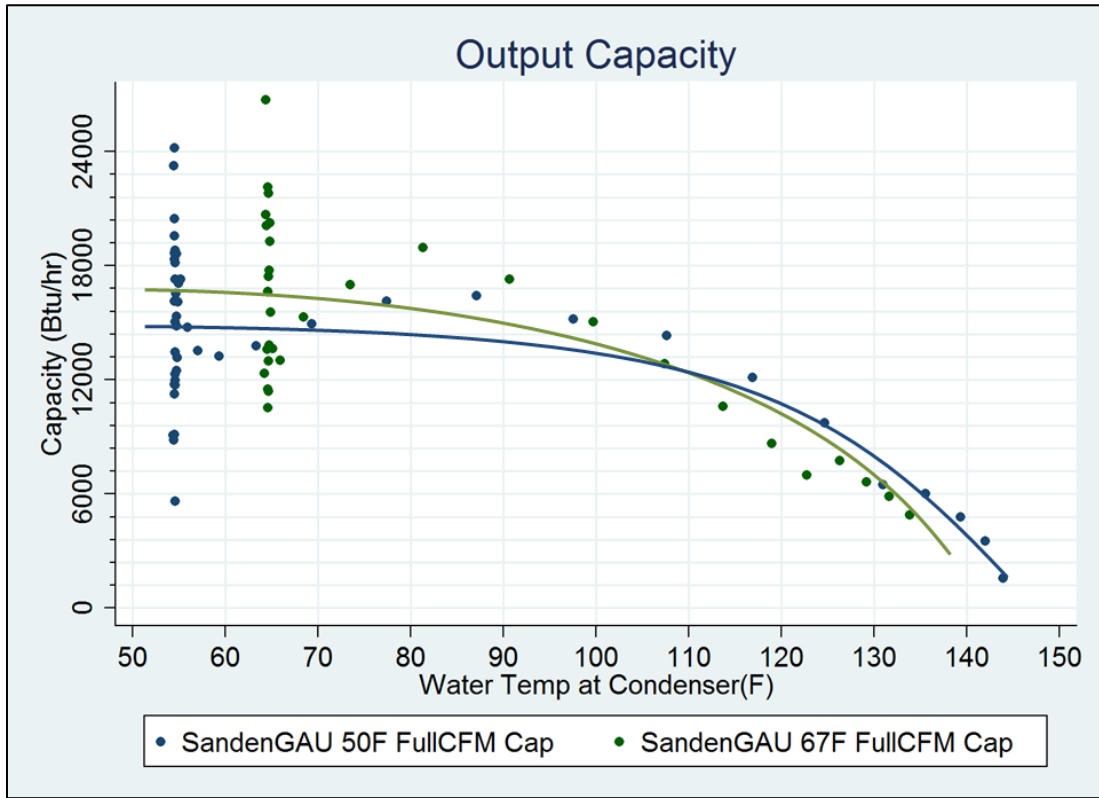

Figure 17. Output Capacity at 50°F & 67°F



## 5 Conclusions

Overall, the results suggest the GAU is an extremely efficient heat pump water heater and suitable for all water heating applications in the Pacific Northwest. This final section of the report discusses observations, on the equipment design and their implications for operation and performance.

- The refrigerant used in all of Sanden's HPWH systems is carbon dioxide (CO<sub>2</sub>). CO<sub>2</sub>, also known as R-744, is widely used in Japan as a response to climate change. The Global Warming Potential (GWP) of CO<sub>2</sub> is 1 as opposed to 2,000 for R-410a and 1320 for R-134a, two typically used refrigerants. R-744 also has a broad range of operating temperatures making it well suited for use as the energy exchange medium between cold outside air temperatures and hot, tank water temperatures. Lab tests showed the equipment had no difficulty heating the tank water to 149°F at an outside temperature of 17°F. Further the manufacturer reports operation to at least -4°F. The operating range makes the equipment well suited for all climates across the Pacific Northwest.
- The inverter-driven, variable speed compressor and fan are efficient and maintain heating output capacity as the ambient temperature decreases. As the outdoor temperature drops, the compressor speeds up. The equipment efficiency decreases but the capacity barely drops. Such characteristics mean that the water heater will be able to heat with the compressor in the winter months. The large size of the air-to-refrigerant heat exchanger is also a key to the system efficiency.
- The operational COPs are notably high for a water heater or any air-source heat pump system. The COPs range from 2.1 at 17°F to 5.0 at 95°F.
- The split-system, with the heat exchanger outside, means there is zero parasitic effect on the house heating system. Most heat pump water heaters currently available on the market come as an integrated unit. When an integrated system is installed inside a house, the HPWH scavenges heat from the house heating system in the wintertime. The split-system has none of those interactive effects.
- There is no resistance element, or any backup heating system with this HPWH. It is designed to always heat with the compressor. This strategy offers significant efficiency advantages because there is no chance for a complicated draw pattern or control strategy to trigger resistance heat as can happen with hybrid HPWHs. At the same time, not having a backup heating method is of potential concern in the event of compressor failure or of outdoor temperatures well below zero, which may prevent the refrigeration cycle from operation.
- The tests show the tank maintains temperature stratification in all operating conditions therefore optimizing the amount of available hot water. This is true despite the water circulation pump which is an integral part of the system design.
- The stainless steel tank and no resistance element obviate the need for an anode rod while simultaneously providing a long life for the tank
- The tested decibels of the outdoor unit are quiet, and compare well to that produced by the outdoor units of ductless heat pumps.
- The unit supplied by Sanden is built and marketed in Australia with some market specific design considerations. The tank is relatively large at 85 gallons. The water heater also has a fixed temperature set point of 149°F (65°C). These features resulted in some adaptations being made to the standard testing procedures. Further, it is likely that a product targeted for the United States market would have a somewhat different control and tank configuration.

## References

ASHRAE Standard 62.2. *ASHRAE Standard 62.2-2010. Ventilation and Acceptable Indoor Air Quality in Low-Rise Residential Buildings*. American Society of Heating, Refrigerating and Air-Conditioning Engineers, Inc., Atlanta, GA.

ASHRAE Standard 118.2. *ASHRAE Standard 118.2-2006 Method of Testing for Rating Residential Water Heaters*. American Society of Heating, Refrigeration and Air Conditioning Engineers, Atlanta, GA. 2006.

DOE 1998. US Department of Energy 10 CFR 430. Federal Register May 11, 1998 Part 430. "Energy Conservation Program for Consumer Products: Uniform Test Method for Measuring the Energy Consumption of Water Heaters" pp. 26008-26016. Retrieved from [http://www1.eere.energy.gov/buildings/appliance\\_standards/residential/pdfs/wtrhtr.pdf](http://www1.eere.energy.gov/buildings/appliance_standards/residential/pdfs/wtrhtr.pdf)

Ecotope, 2010. *Residential Heat Pump Water Heater Evaluation Project Measurement & Verification Plan*. Prepared for Bonneville Power Administration. Retrieved from [http://www.bpa.gov/energy/n/emerging\\_technology/pdf/HPWH\\_MV\\_Plan\\_Final\\_012610.pdf](http://www.bpa.gov/energy/n/emerging_technology/pdf/HPWH_MV_Plan_Final_012610.pdf)

Larson and Logsdon, 2011. *Residential Heat Pump Water Heater Evaluation: Lab Testing & Energy Use Estimates*. Prepared for Bonneville Power Administration Retrieved from [http://www.bpa.gov/energy/n/emerging\\_technology/pdf/HPWH\\_Lab\\_Evaluation\\_Final\\_Report\\_20111109.pdf](http://www.bpa.gov/energy/n/emerging_technology/pdf/HPWH_Lab_Evaluation_Final_Report_20111109.pdf)

Northwest Energy Efficiency Alliance, 2012. *Northern Climate Heat Pump Water Heater Specification* Retrieved from <http://neea.org/northernclimatespec/>

Uniform Plumbing Code, 2009. 2009 Uniform Plumbing Code. International Association of Plumbing and Mechanical Officials. Ontario, CA. Retrieved from <http://ia600405.us.archive.org/24/items/gov.law.iapmo.upc.2009/iapmo.upc.2009.pdf>

## Appendix A: Testing Matrices

DOE Standard Rating Point Tests											
Test Name	Ambient Air Conditions					Inlet Water		Outlet Water		Flow Rate	Notes
	Dry-Bulb		Wet-Bulb		RH	F	C	F	C	GPM	
	F	C	F	C							
DOE-1hr	67.5	20	57	14	50%	58	14	149	65	3.0	Follow test sequence in Federal Register 10 CFR Part 430 Section <b>5.1.4</b>
DOE-24hr	67.5	20	57	14	50%	58	14	149	65	3.0	Follow test sequence in Federal Register 10 CFR Part 430 Section <b>5.1.5</b>

Modified DOE Standard Rating Point Tests											
MDOE-24hr-95	95	35	75	24	40%	50	10	149	65	3.0	Follow test sequence in Federal Register 10 CFR Part 430 Section <b>5.1.5</b> but replace ambient conditions with those given in this table.
MDOE-24hr-50	50	10	44	7	58%	50	10	149	65	3.0	
MDOE-24hr-35	35	2	33	1	80%	50	10	149	65	3.0	
MDOE-24hr-17	17	-8	15	-9	70%	50	10	149	65	3.0	

Draw Profiles											
DP-SHW-50	50	10	44	7	58%	50	10	149	65	1.5	Draw Profile: DP-SHW. Conduct identical, repeated draws until ending conditions observed. Flow rate reduced to compensate for higher tank setpoint.

COP Curve - Performance Mapping											
COP-50	50	10	44	7	58%	55	13	149	65	na	The starting tank water temperature can be 50F-70F, or some other convenient value based on what the current conditioned water supply tank is using.
COP-67	67.5	20	57	14	50%	65	18	149	65	na	

Noise Measurement											
NOI	Measure combined fan and compressor noise									na	Make measurement of indoor unit (this is likely 0). Make measurement of outdoor unit. Test method TBD but will be similar to the NC spec.

Additional Observations											
AO-VOL	Measure tank water volume									na	
AO-PWR	One-time measurements of component power									na	Make one time measurement (if possible) of outdoor unit fan power draw, circuit board power draw, and any of system components.

## Appendix B: Measurement Instrumentation List

Equipment	Make and Model	Function	Accuracy	Calibration Expiration Date
Walk-in Chamber	Make : ESPEC, Model No.: EWSX499-30CA	Test environment temperature and relative humidity control	$\pm 1\text{ }^{\circ}\text{C}$	8/13/2013
Data Acquisition System	Make : Agilent Technologies, Model No : Agilent 34970A	Log temperature, power and flow rate data	Voltage: 0.005% of reading + 0.004% of range Temperature: (Type T):1.5 $^{\circ}\text{C}$	7/31/2013
Thermocouple	OMEGA, T type	Temperature measurement	0.8 $^{\circ}\text{C}$	Note 1
Power Meter	Acuvim II – Multifunction Power Meter with AXM-I02 I/O Module	Continuous power measurement as necessary (system, heater and heat pump)	Main Unit: 0.2% full scale for voltage and current AXM-I02 Analog Output: 0.5% full scale + 1% resistor tolerance	Note 2
Ammeter	LH41	One-time fan power measurement	1mA in 4A range 10mA in 40A range	Note 2
Flow Control	Control: Systems Interface Inc. Flow meter: Signet 2537 paddlewheel	Water draw rate and amount control	Note 3	Note 3
Electronic Scale	OXO “Good Grips” Scale	Measurement of water mass	5.0 Kg full scale with 1 g increment	8/16/2013
Hand-held Temperature and Humidity Meter	Omega RH820W	Lab environment temperature and humidity measurement	$\pm 0.5\text{ }^{\circ}\text{C}$	Note 6
Electronic Scale	Dymo Pelouze Model: 4040 Range 180 Kg	Measurement of water mass	$\pm 0.2\text{ Kg}$	Note 6
Inlet Water Conditioning System	Temp control: TCS-4010	Conditioning of unit under test inlet water temperature	$\pm 1\text{ }^{\circ}\text{C}$	Note 5

**Notes:**

1. Thermocouples are calibrated using Omega CL1500 system.
2. Each Acuvim II along with current transformer and LH41 Clamp-on Ammeter are checked against a calibrated power/current meter.
3. Flow control is checked by actual collected water weight measurement at required GPM.
4. Airflow meter is provided by Ecotope.
5. This is not used for inlet water temp data used in calculations.
6. Checked against calibrated instrument/device.



### Appendix C: Supplemental Graphics

